

01 Existing Bedroom Windows

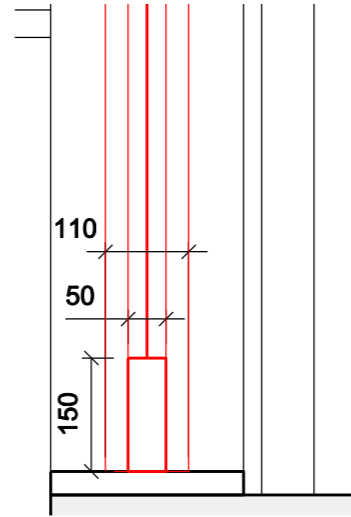

02 Existing Hallway Window

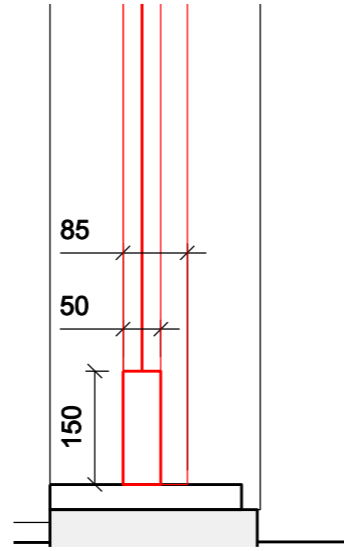

03 Existing Livingroom Window

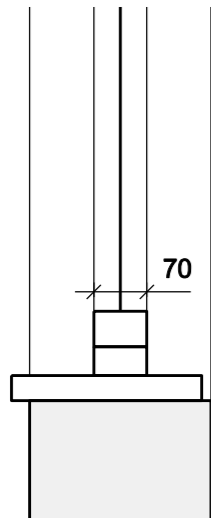

04 Proposed Bedroom Windows

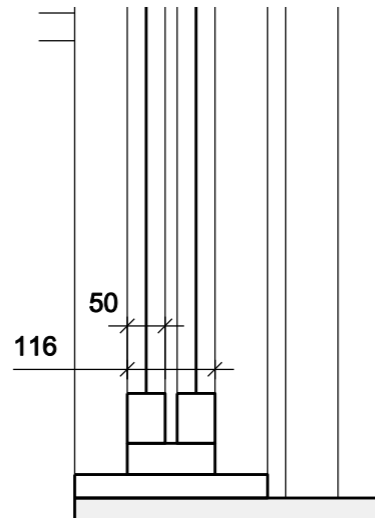

05 Proposed Hallway Window

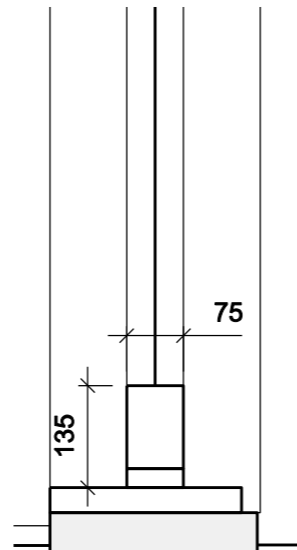

06 Proposed Livingroom French Doors

NOTES:	KEY:	Orientation	P00 27/10/2023 FOR PLANNING		McNeil Architects Ltd 8 Lindley Road London E10 8QT www.mcneilarchitects.com t: 07970 982 387
			revision date ammendment - This drawing is for planning submission purposes only - do not scale from this drawing - all dimensions to be checked on site by the contractor - report all omissions and/or errors to McNeil Architects - all dimensions in millimetres unless otherwise stated - if in doubt contact administrator for clarification - all drawings are the copyright of McNeil Architects Ltd		
			job title 2 FALKLAND PLACE drawing title EXISTING & PROPOSED WINDOWS/DOORS		
			status For Planning drawing no revision scale 1:10 @ A3 054-P-020 P00		
			job no 054		