



01 Proposed Front Elevation
1:100@A3

02 Proposed Section
1:100@A3

- 01 Slate tiles
- 02 Black RAL 9006 TimberFrame - Double Glazed Windows with bronze reveal detail
- 03 ~~Aluminum Perforated Screening - Copper finish~~
- 04 Black Slip Brick (Vandersanden - Morvan) Motar - Joint free.
- 05 Skylight
- 06 Breaker tank / pump (Plant)

All dimensions must be checked and PAPA Architects Ltd are to be informed of any discrepancies prior to construction. Any DWG's issued by PAPA Architects Ltd are to be read in conjunction with the associated PDF versions. This drawing and any of the details therein remain the copyright of PAPA Architects Ltd. All drawings prepared by PAPA Architects are not to be used for any submissions, area schedule calculations or used by any other persons or companies other than PAPA Architects Ltd unless written consent has been given by PAPA Architects Ltd.

Rev	Date	Description	Chk
P01	14.02.23	For Information	NP
P02	14.08.23	For Information	NP
P03	31.10.23	Planning amendments	NP

PAPAArchitects
 222 Archway Road, Highgate, London N6 5AX
 w: papaarchitects.co.uk t: +44 20 8348 8411

Drawing Title:		Project Name:		Client:	
Proposed Front Elevation		15 Balsize Park Mews NW3 5BL			
Project No:	Drawing No:	Rev:	Scale:	Status:	Date:
2211	00-210	P03	1:100@A3	PLANNING	23.01.23
			Drawn:		TN

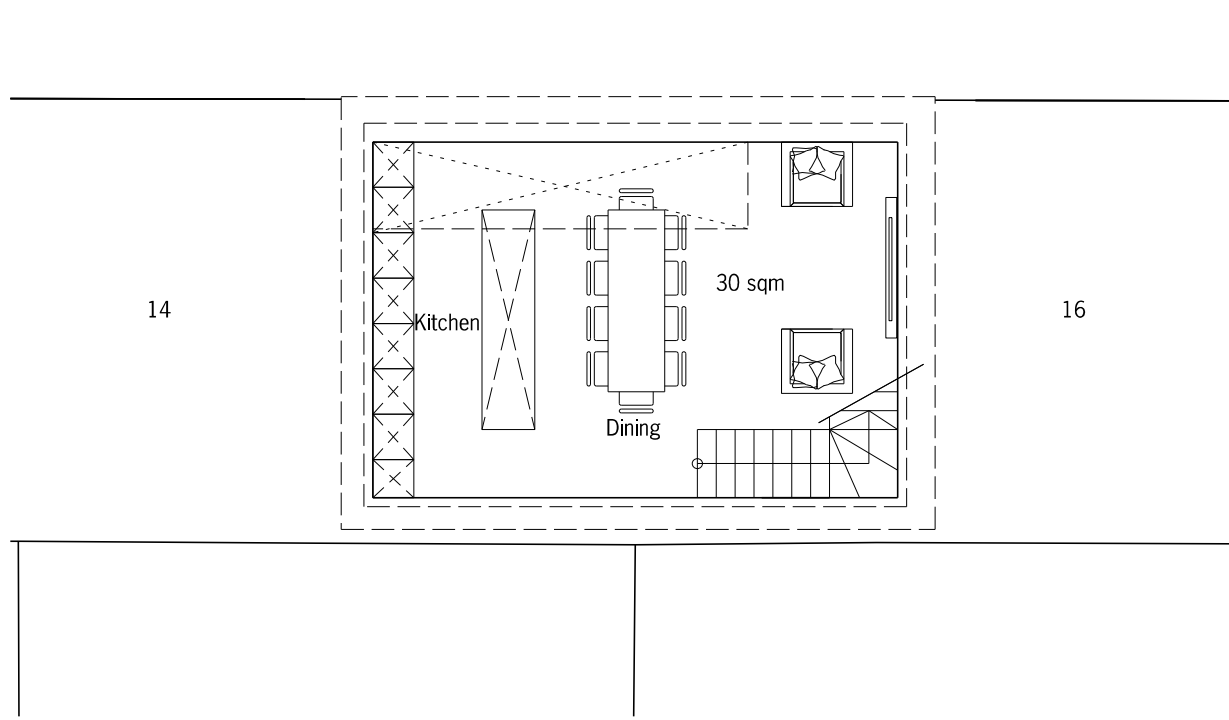

01 Proposed Basement Plan
1:100@A3

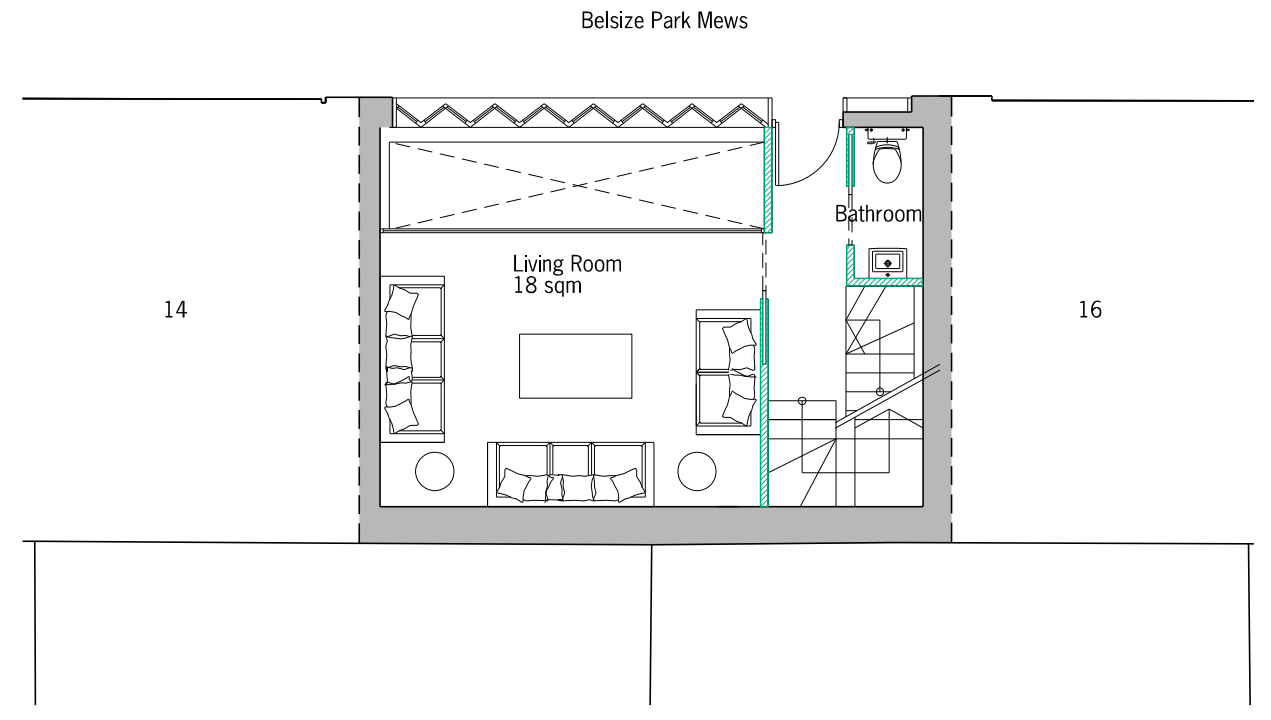

02 Proposed Ground Floor Plan
1:100@A3

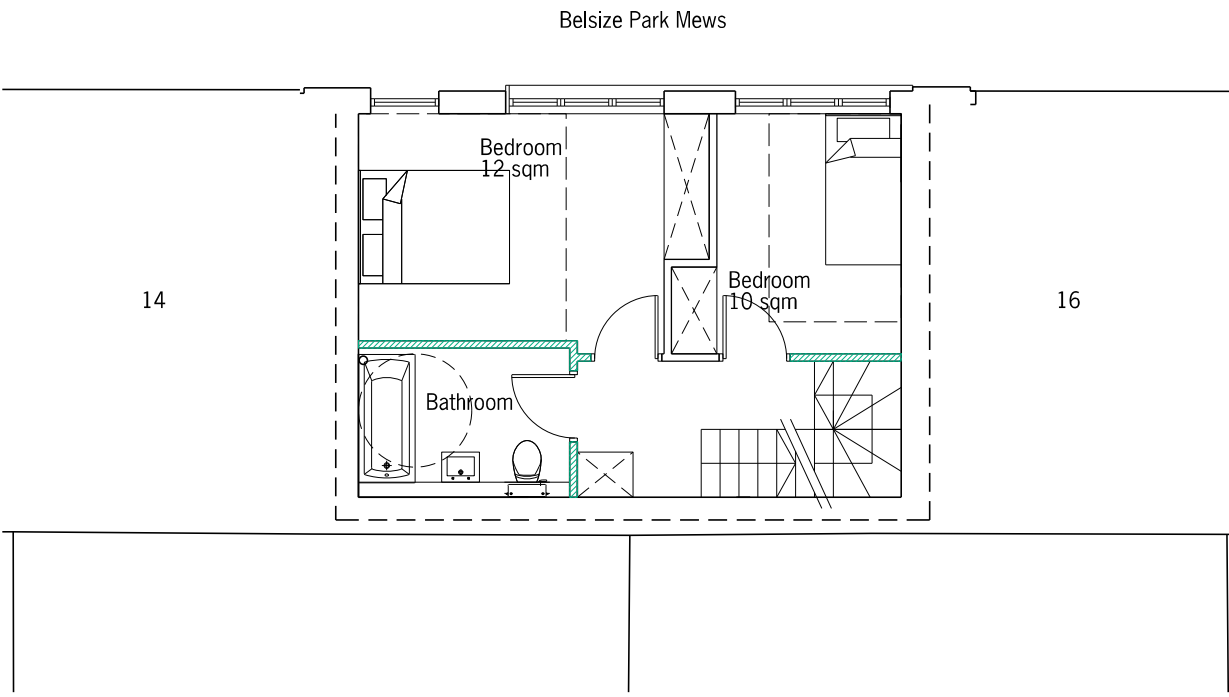

03 Proposed First Floor Plan
1:100@A3

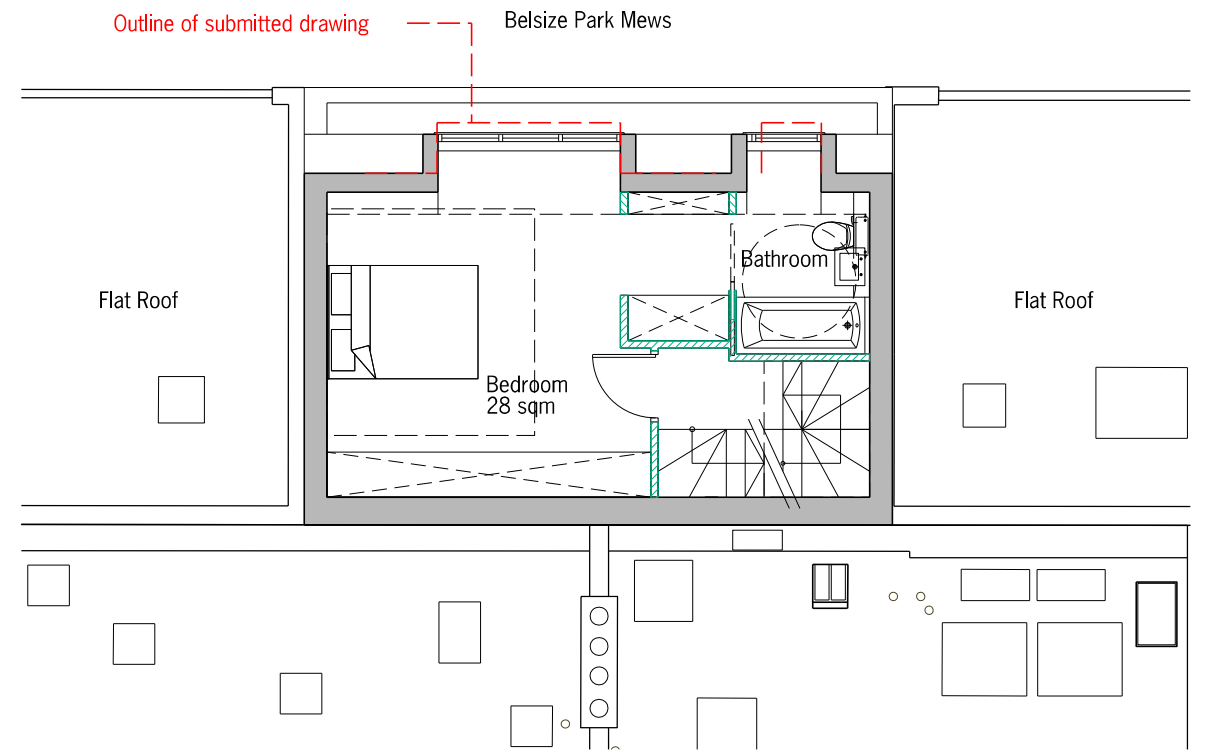

04 Proposed Second Floor Plan
1:100@A3

All dimensions must be checked and PAPA Architects Ltd are to be informed of any discrepancies prior to construction. Any DWG's issued by PAPA Architects Ltd are to be read in conjunction with the associated PDF versions. This drawing and any of the details therein remain the copyright of PAPA Architects Ltd. All drawings prepared by PAPA Architects are not to be used for any submissions, area schedule calculations or used by any other persons or companies other than PAPA Architects Ltd unless written consent has been given by PAPA Architects Ltd.

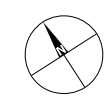

Rev	Date	Description	Chk
P01	23.01.23	For Information	NP
P02	09.08.23	Planning Submission	NP
P03	31.10.23	Minor amendments	NP

PAPAARCHITECTS
222 Archway Road, Highgate, London N6 5AX
w: papaarchitects.co.uk t: +44 20 8348 8411

Drawing Title:	Project Name:	Client:
Proposed Floor Plans	15 Belsize Park Mews NW3 5BL	
Project No:	Drawing No:	Rev:
2211	00-201	P03
Scale:	Status:	Date:
1:100@A3	PLANNING	11.01.23
Drawn:		
TN		

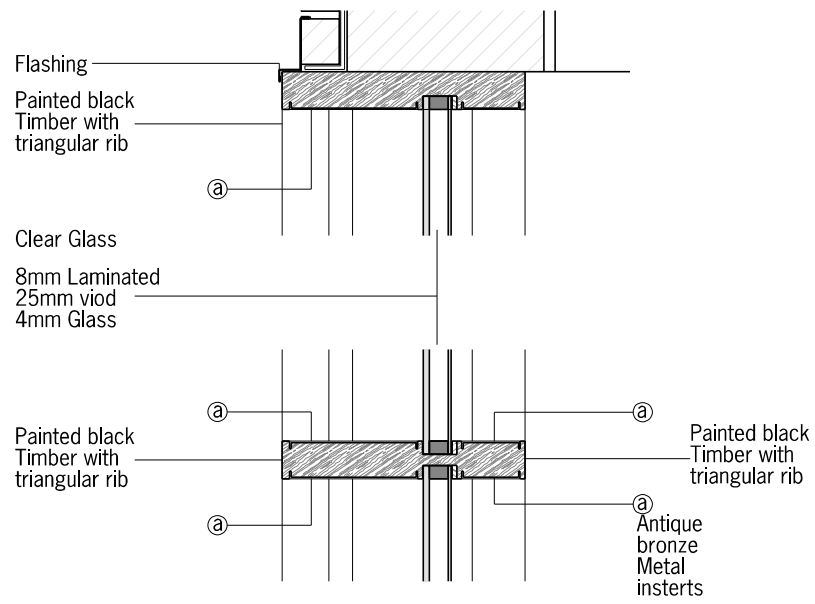
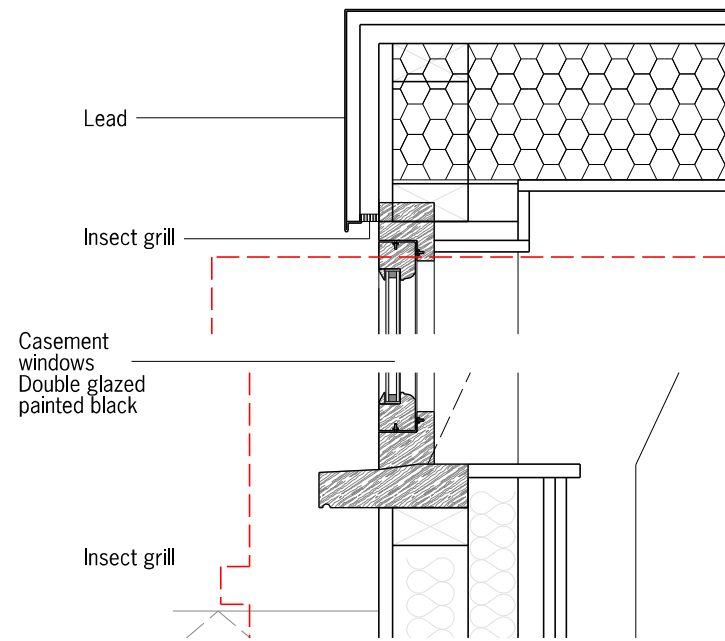

01 Dormer Section
1:10@A3

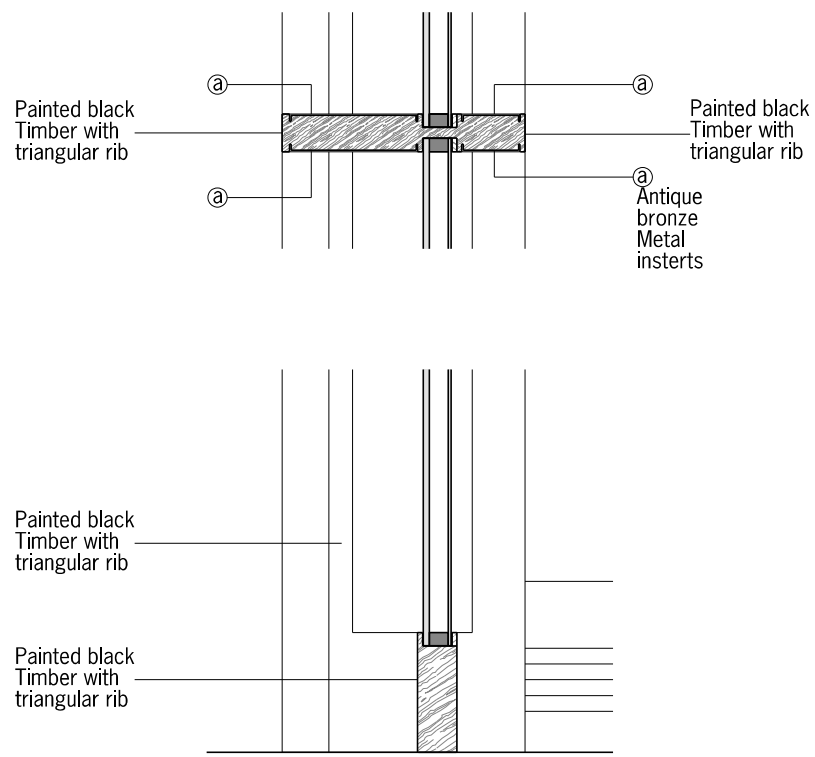
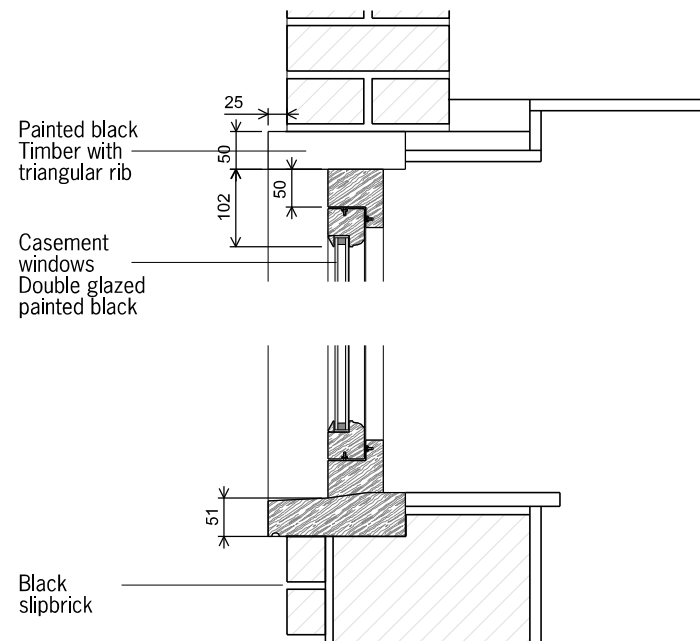

02 First floor window
1:10@A3

All dimensions must be checked and PAPA Architects Ltd are to be informed of any discrepancies prior to construction. Any DWG's issued by PAPA Architects Ltd are to be read in conjunction with the associated PDF versions. This drawing and any of the details therein remain the copyright of PAPA Architects Ltd. All drawings prepared by PAPA Architects are not to be used for any submissions, area schedule calculations or used by any other persons or companies other than PAPA Architects Ltd unless written consent has been given by PAPA Architects Ltd.



Rev	Date	Description	Chk
P01	31.10.23	Planning Submission	NP

PAPAArchitects
222 Archway Road, Highgate, London N6 5AX
w: papaarchitects.co.uk t: +44 20 8348 8411

Drawing Title:		Project Name:		Client	
Details		15 Belsize Park Mews, NW3			
Project No:	Drawing No:	Rev:	Scale:	Status:	Date:
2211	00 401	P01	1:50@A3	PLANNING	31.10.23

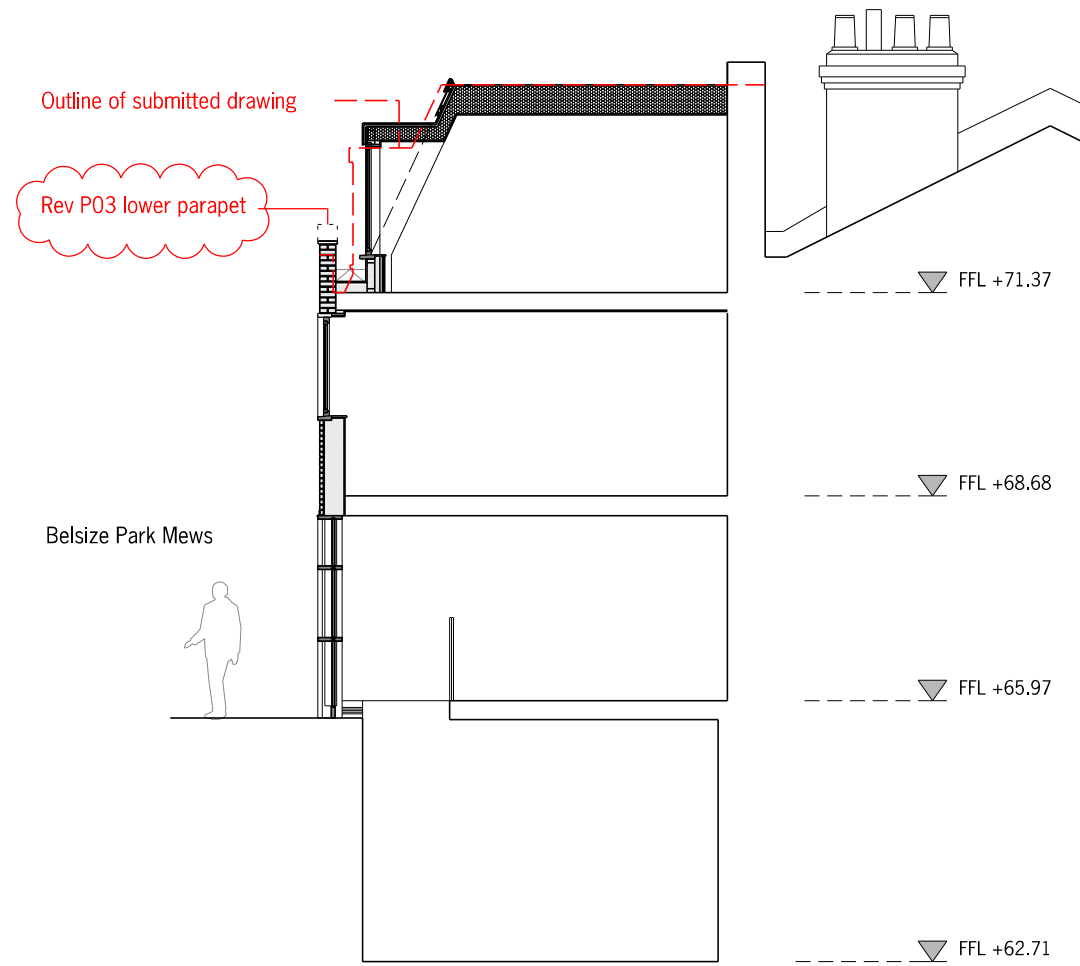

01 Proposed Section
1:100@A3

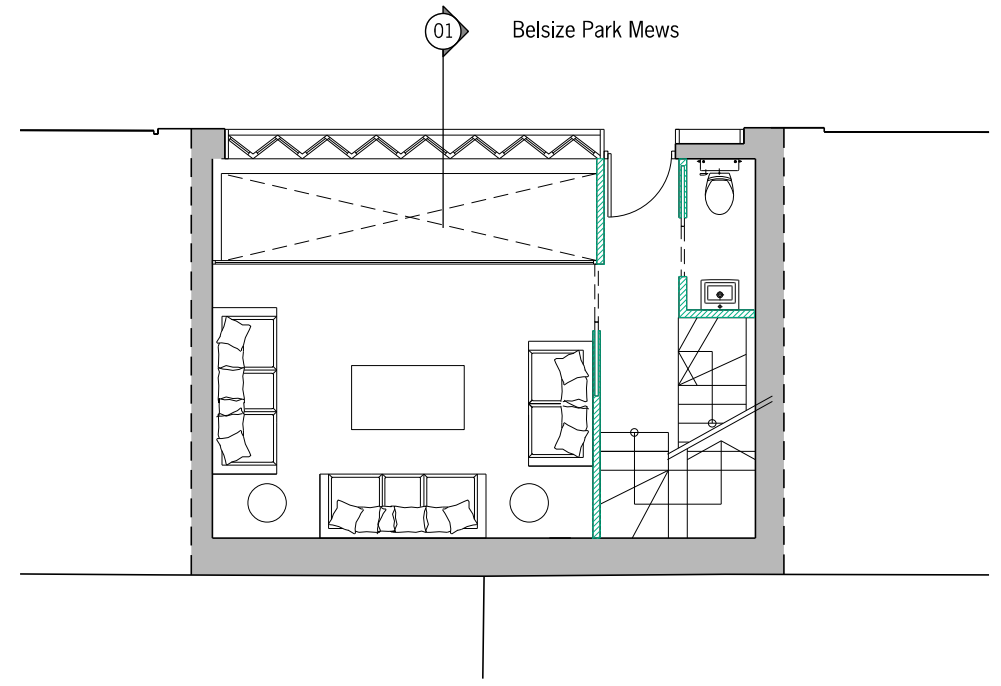

02 Ground Floor
1:100@A3

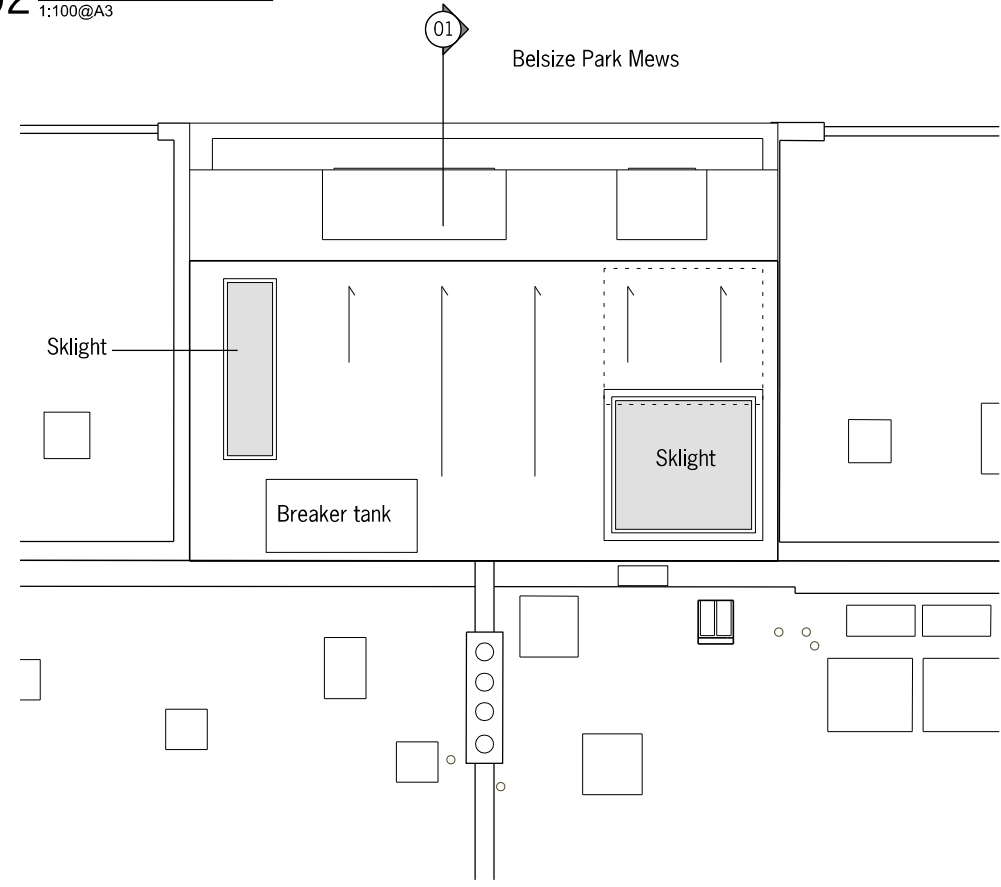

03 Roof Plan
1:100@A3

All dimensions must be checked and PAPA Architects Ltd are to be informed of any discrepancies prior to construction. Any DWG's issued by PAPA Architects Ltd are to be read in conjunction with the associated PDF versions. This drawing and any of the details therein remain the copyright of PAPA Architects Ltd. All drawings prepared by PAPA Architects are not to be used for any submissions, area schedule calculations or used by any other persons or companies other than PAPA Architects Ltd unless written consent has been given by PAPA Architects Ltd.

Rev	Date	Description	Chk
P01	06.03.23	For Information	NP
P02	09.08.23	For Information	NP
P03	31.10.23	Planning amendments	NP

PAPAArchitects
222 Archway Road, Highgate, London N6 5AX
w: papaarchitects.co.uk t: +44 20 8348 8411

Drawing Title:		Project Name:		Client:	
Proposed Section + Roof Plan		15 Belsize Park Mews NW3 5BL			
Project No:	Drawing No:	Rev:	Scale:	Status:	Date:
2211	00-210	P03	1:100@A3	PLANNING	06.03.23

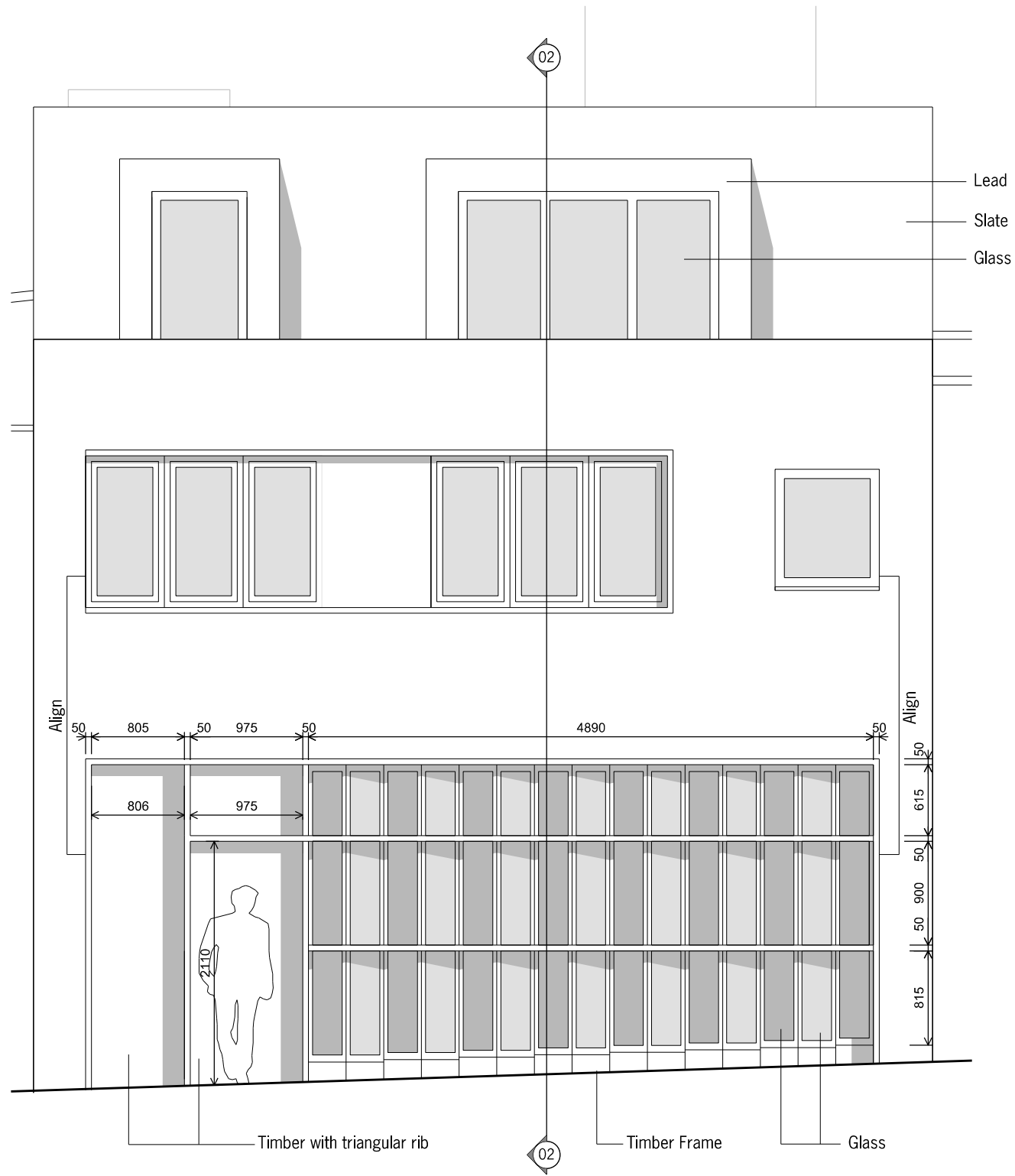

01 Elevation
1:50@A3

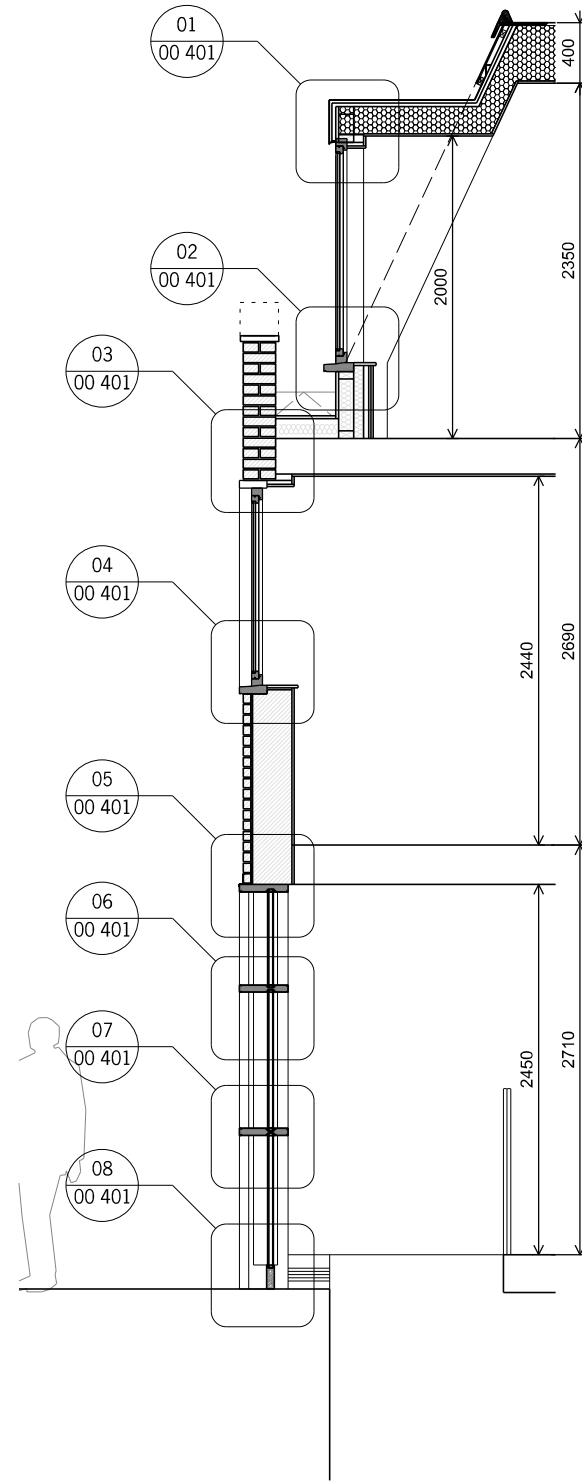

02 Section
1:50@A3

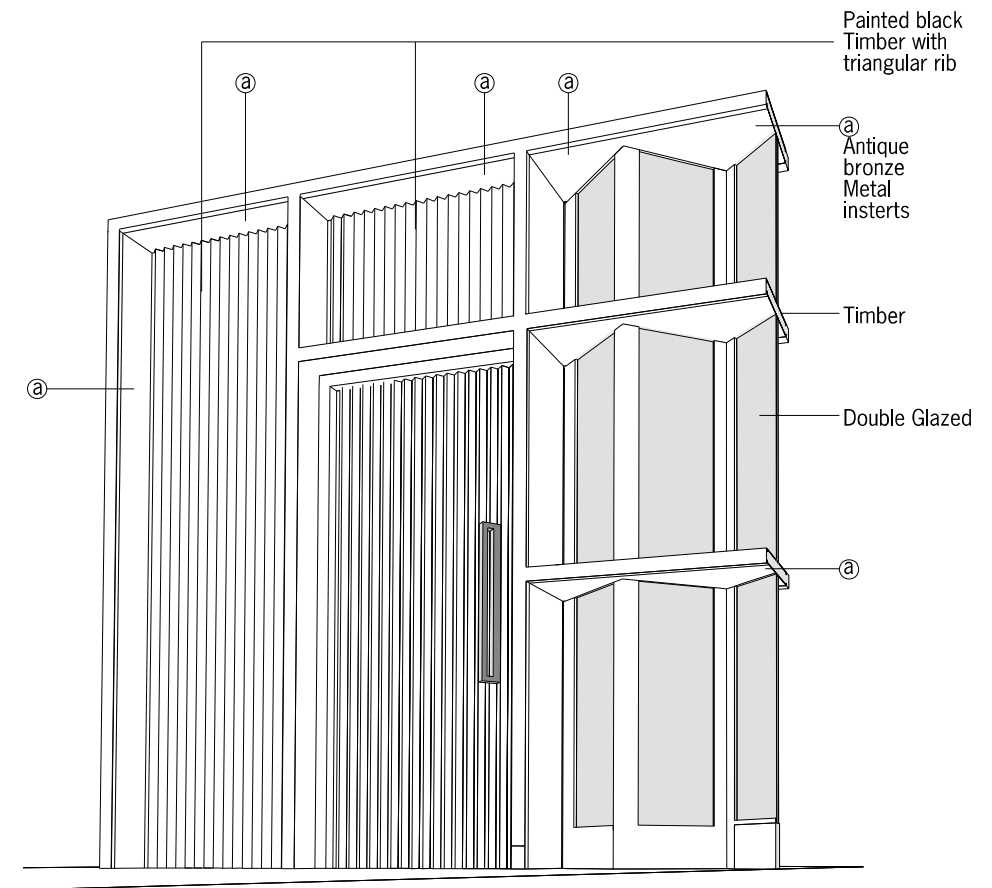

03 Ground Floor Plan
1:50@A3

All dimensions must be checked and PAPA Architects Ltd are to be informed of any discrepancies prior to construction. Any DWG's issued by PAPA Architects Ltd are to be read in conjunction with the associated PDF versions. This drawing and any of the details therein remain the copyright of PAPA Architects Ltd. All drawings prepared by PAPA Architects are not to be used for any submissions, area schedule calculations or used by any other persons or companies other than PAPA Architects Ltd unless written consent has been given by PAPA Architects Ltd.



Rev	Date	Description	Chk
P01	31.10.23	Planning Submission	NP

PAPAArchitects
222 Archway Road, Highgate, London N6 5AX
w: papaarchitects.co.uk t: +44 20 8348 8411

Drawing Title:		Project Name:		Client:	
Details		15 Belsize Park Mews, NW3			
Project No:	Drawing No:	Rev:	Status:	Date:	Drawn:
2211	00 400	P01	1:50@A3	PLANNING	31.10.23