

IMPORTANT INFORMATION:

- DO NOT SCALE THIS DRAWING, DRAWINGS AVAILABLE ON REQUEST.
- ALL DIMENSIONS ARE IN MILLIMETRES, UNLESS OTHERWISE STATED.
- THIS DRAWING IS CONFIDENTIAL AND THE COPYRIGHT IS VESTED IN STUDIOLET LTD.
- IT MUST NOT BE COPIED, LENT OR DISCLOSED TO A THIRD PARTY, WITHOUT THE WRITTEN CONSENT OF STUDIOLET LTD.
- IT IS SUBJECT TO RECALL & REVISION CONTROL.

NOTES: **Studiolet Ltd**
26 Cleveland Gardens, London W2 6DE

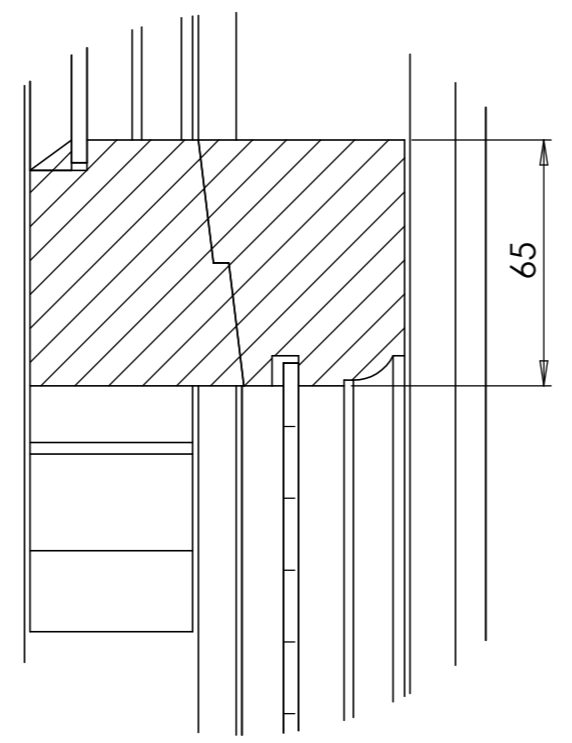
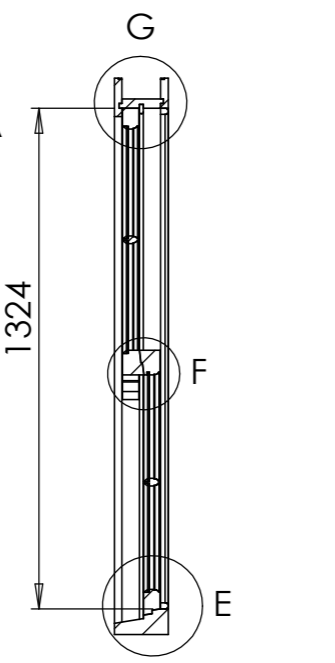
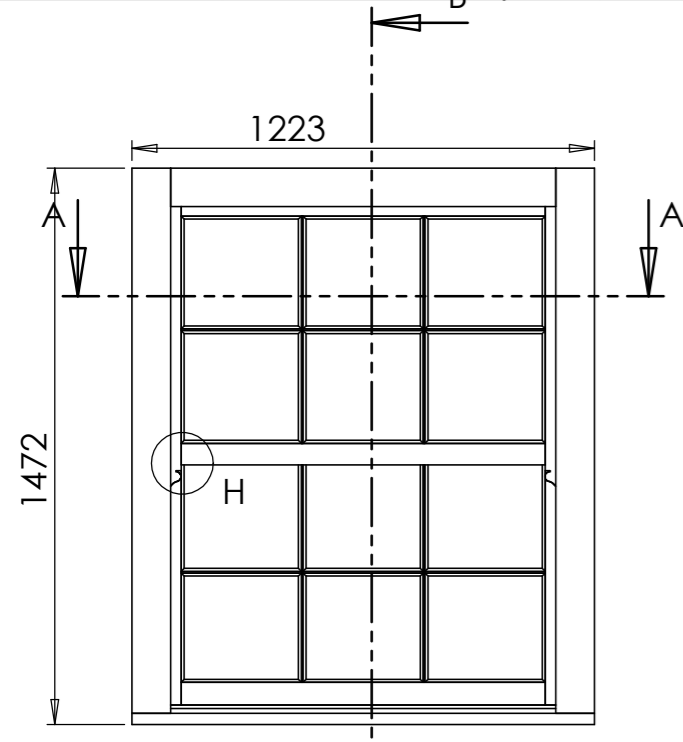

DETAIL F
SCALE 1 : 2

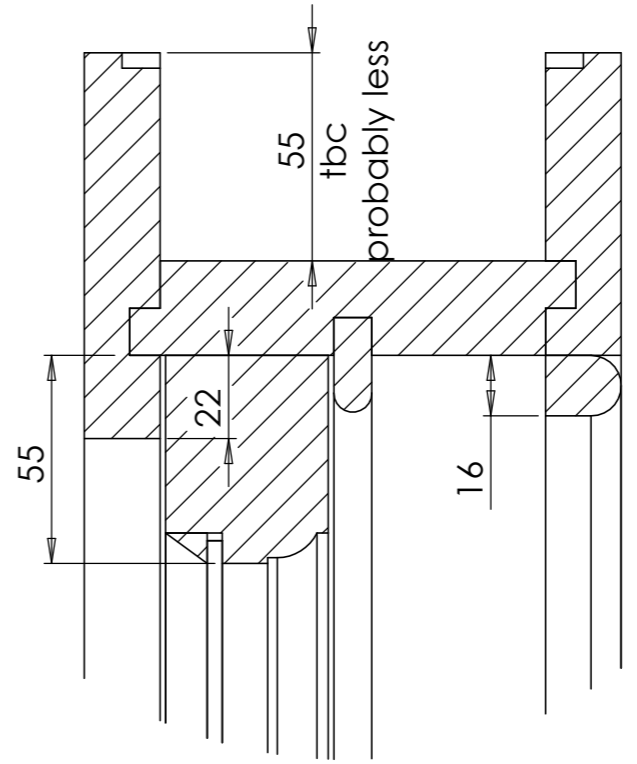

DETAIL G
SCALE 1 : 2

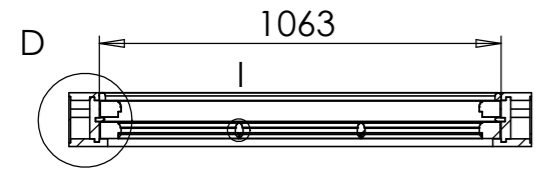

SECTION A-A

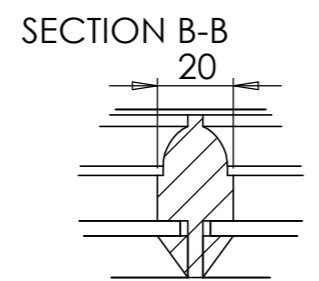

DETAIL I
SCALE 1 : 2

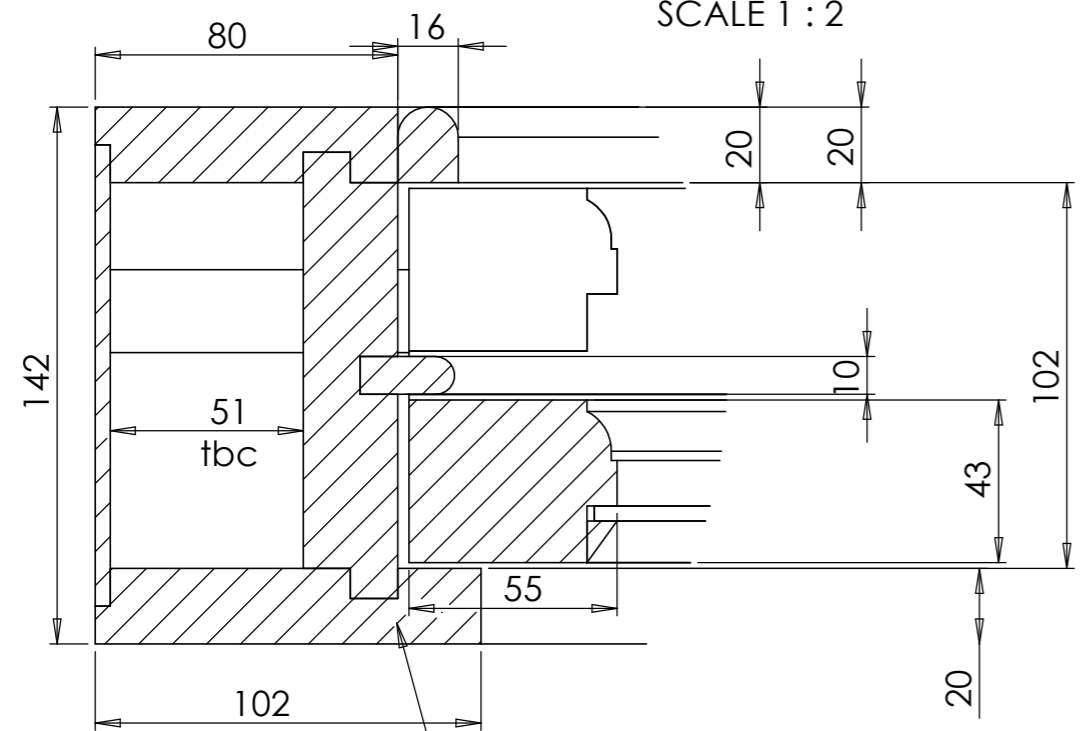

DETAIL D
SCALE 1 : 2

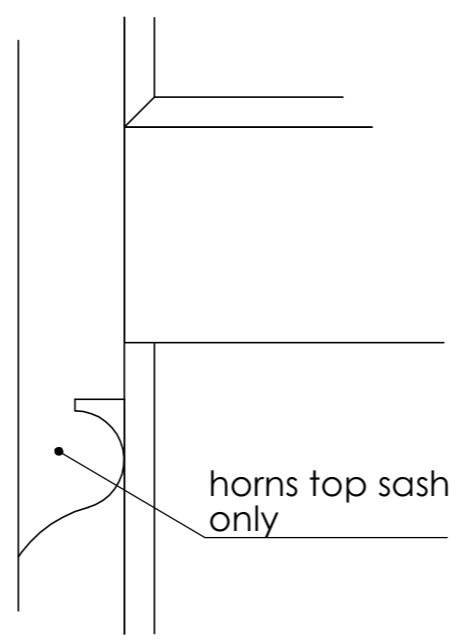

DETAIL H
SCALE 1 : 2

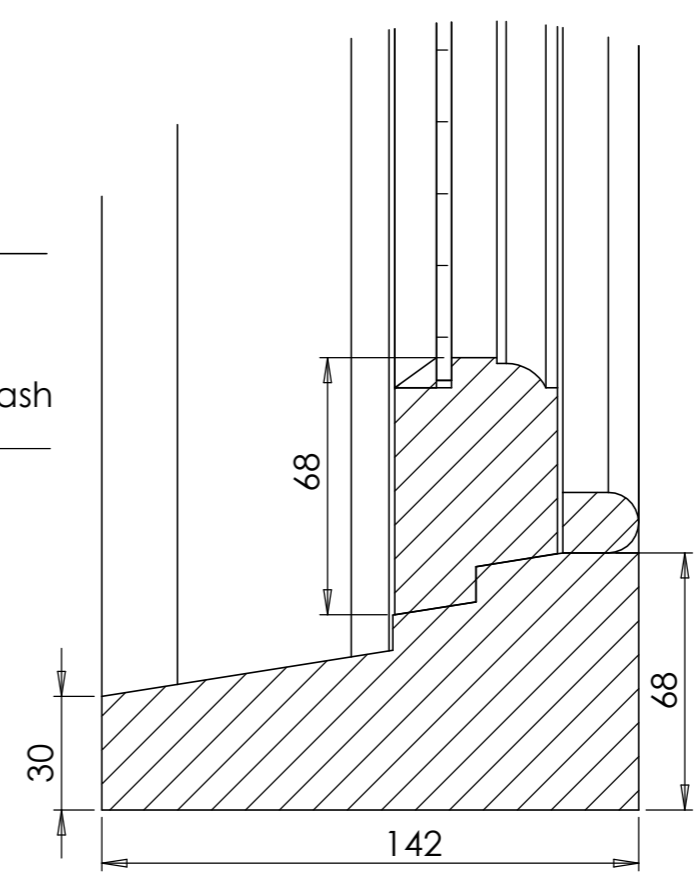

DETAIL E
SCALE 1 : 2

TYPE8 WTR2

REVISION HISTORY

| | |
|-------|---------|
| REV A | Primary |
| REV B | |
| REV C | |
| REV D | |
| REV E | |

DO NOT SCALE THIS DRAWING, DWG'S AVAILABLE ON REQUEST.
ALL DIMENSIONS IN MM UNLESS OTHERWISE NOTED

| | NAME | SIGNATURE | DATE |
|-----------------|------|-----------|--------------|
| DRAWN BY: | HM | | 21 June 2023 |
| LAST EDIT DATE: | | | |
| APPROVED BY: | | | |

DRAWING ISSUE STATUS:

| | | |
|-----------|---------|------------------|
| MATERIAL: | FINISH: | SHEET SIZE A3 |
|-----------|---------|------------------|

CUSTOMER: Studiolet
PROJECT: 64-65 Guilford Street

TITLE:
Existing modern windows
Type 8 (to be replaced)

| | | |
|----------------------|---------------|------------------------|
| DWG NO. ST-GU-187 | REVISION A | THIRD ANGLE PROJECTION |
|----------------------|---------------|------------------------|

IMPORTANT INFORMATION:

- DO NOT SCALE THIS DRAWING, DRAWINGS AVAILABLE ON REQUEST.
- ALL DIMENSIONS ARE IN MILLIMETRES, UNLESS OTHERWISE STATED.
- THIS DRAWING IS CONFIDENTIAL AND THE COPYRIGHT IS VESTED IN STUDIOLET LTD.
- IT MUST NOT BE COPIED, LENT OR DISCLOSED TO A THIRD PARTY, WITHOUT THE WRITTEN CONSENT OF STUDIOLET LTD.
- IT IS SUBJECT TO RECALL & REVISION CONTROL.

NOTES:

Studiolet Ltd

26 Cleveland Gardens, London W2 6DE

NOTES

- 1 These are the details of the existing Type8 windows which it is hoped will be replaced.
- 2 Permission should be sought from the listing authority to carry out any work on the windows.
- 3 The box depth needs to be confirmed on site. Plaster has not been removed to ascertain this thickness.
- 4 It is critical that the plaster reveal on the outside (ie the amount of frame showing beyond the render), is matched with the Type3 windows on the second floor if these windows are replaced.
- 5 It is hoped that the listing authority may agree to the fitting of some draught seals following consultation.
- 6 Some details like that at the cill are weak. It would be advisable to consult with the listing authority as to whether some changes can be made.

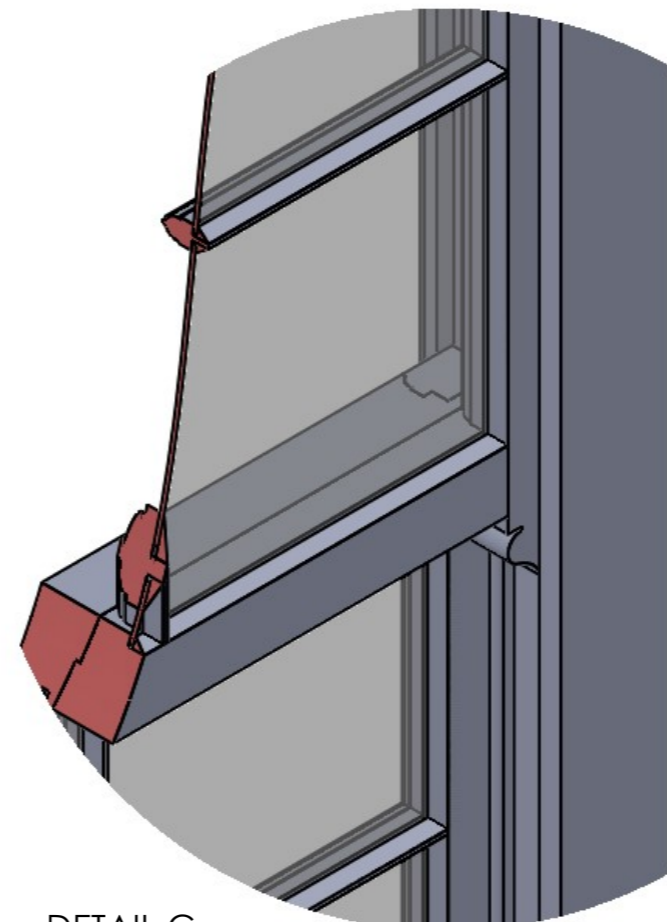
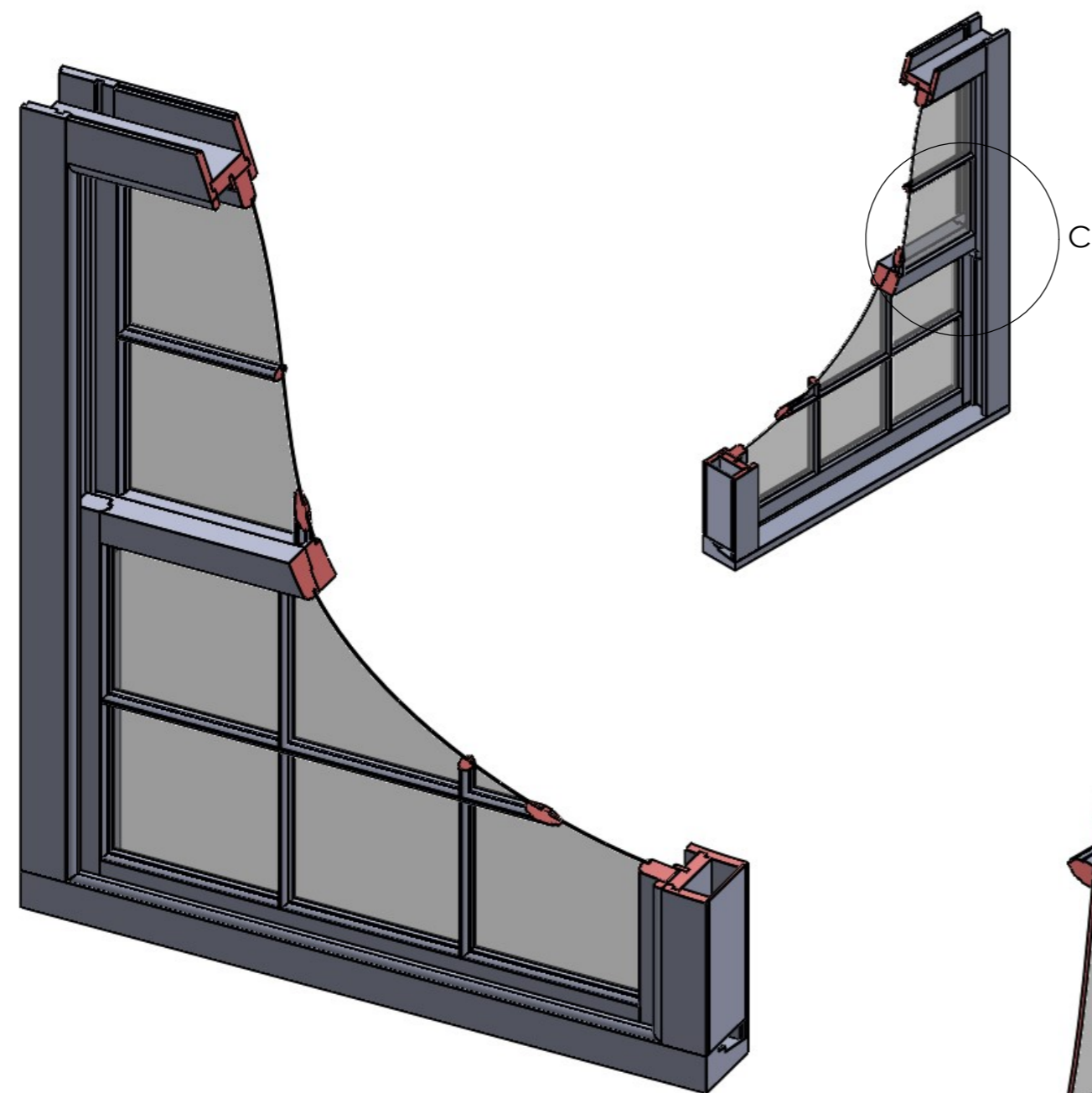

DETAIL C
SCALE 1 : 5

TYPE8 WTR2

REVISION HISTORY

| | |
|-------|---------|
| REV A | Primary |
| REV B | |
| REV C | |
| REV D | |
| REV E | |

DO NOT SCALE THIS DRAWING, DWG'S AVAILABLE ON REQUEST.

ALL DIMENSIONS IN MM UNLESS OTHERWISE NOTED

| | NAME | SIGNATURE | DATE |
|-----------------|------|-----------|--------------|
| DRAWN BY: | HM | | 21 June 2023 |
| LAST EDIT DATE: | | | |
| APPROVED BY: | | | |

DRAWING ISSUE STATUS:

| | | |
|-----------|---------|------------------|
| MATERIAL: | FINISH: | SHEET SIZE A3 |
|-----------|---------|------------------|

CUSTOMER: Studiolet

PROJECT: 64-65 Guilford Street

TITLE:
Existing modern windows
Type 8 (to be replaced)

| | | |
|----------------------|---------------|------------------------|
| DWG NO. ST-GU-187 | REVISION A | THIRD ANGLE PROJECTION |
|----------------------|---------------|------------------------|