

IMPORTANT INFORMATION:

- DO NOT SCALE THIS DRAWING, DRAWINGS AVAILABLE ON REQUEST.
- ALL DIMENSIONS ARE IN MILLIMETRES, UNLESS OTHERWISE STATED.
- THIS DRAWING IS CONFIDENTIAL AND THE COPYRIGHT IS VESTED IN STUDIOLET LTD.
- IT MUST NOT BE COPIED, LENT OR DISCLOSED TO A THIRD PARTY, WITHOUT THE WRITTEN CONSENT OF STUDIOLET LTD.
- IT IS SUBJECT TO RECALL & REVISION CONTROL.

NOTES:

Studiolet Ltd

26 Cleveland Gardens, London W2 6DE

NOTES

- 1 These are the details of the existing Type3 windows.
- 2 Permission should be sought from the listing authority to carry out any work on the windows.
- 3 The box depth needs to be confirmed on site. Plaster has not been removed to ascertain this thickness.
- 4 It is critical that the plaster reveal on the outside (ie the amount of frame showing beyond the render), is maintained.
- 5 It is hoped that the listing authority may agree to the fitting of some draught seals following consultation.
- 6 Some details like that at the cill are weak. It would be advisable to consult with the listing authority as to whether some changes can be made.

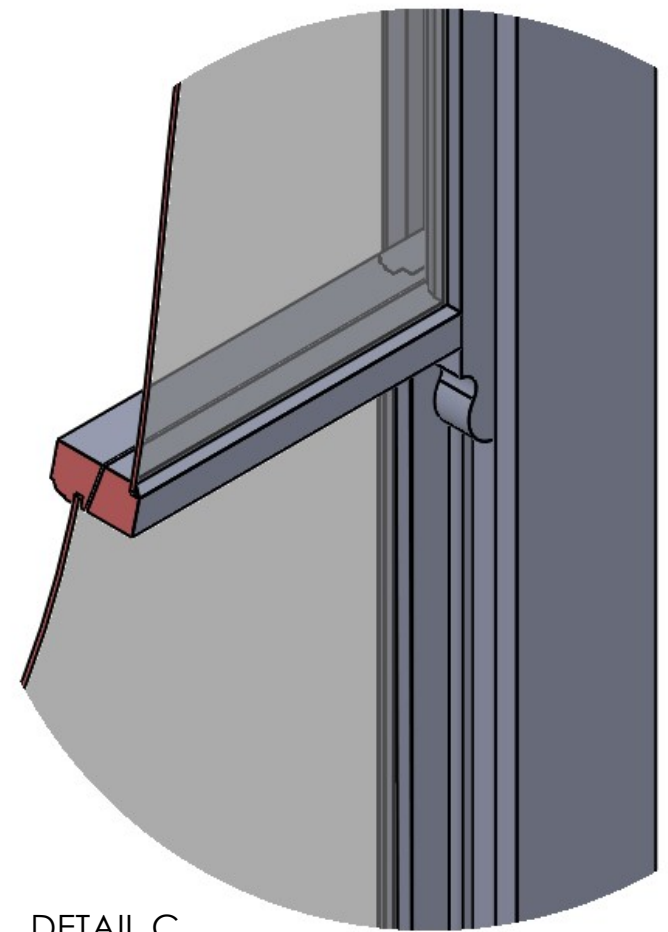
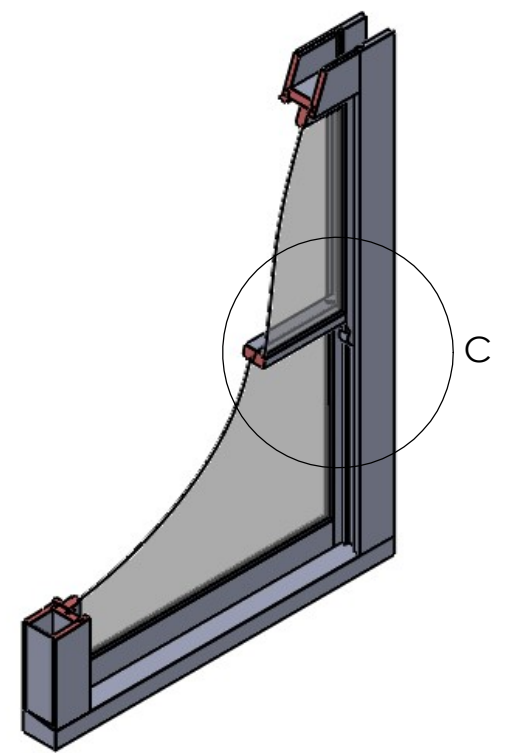
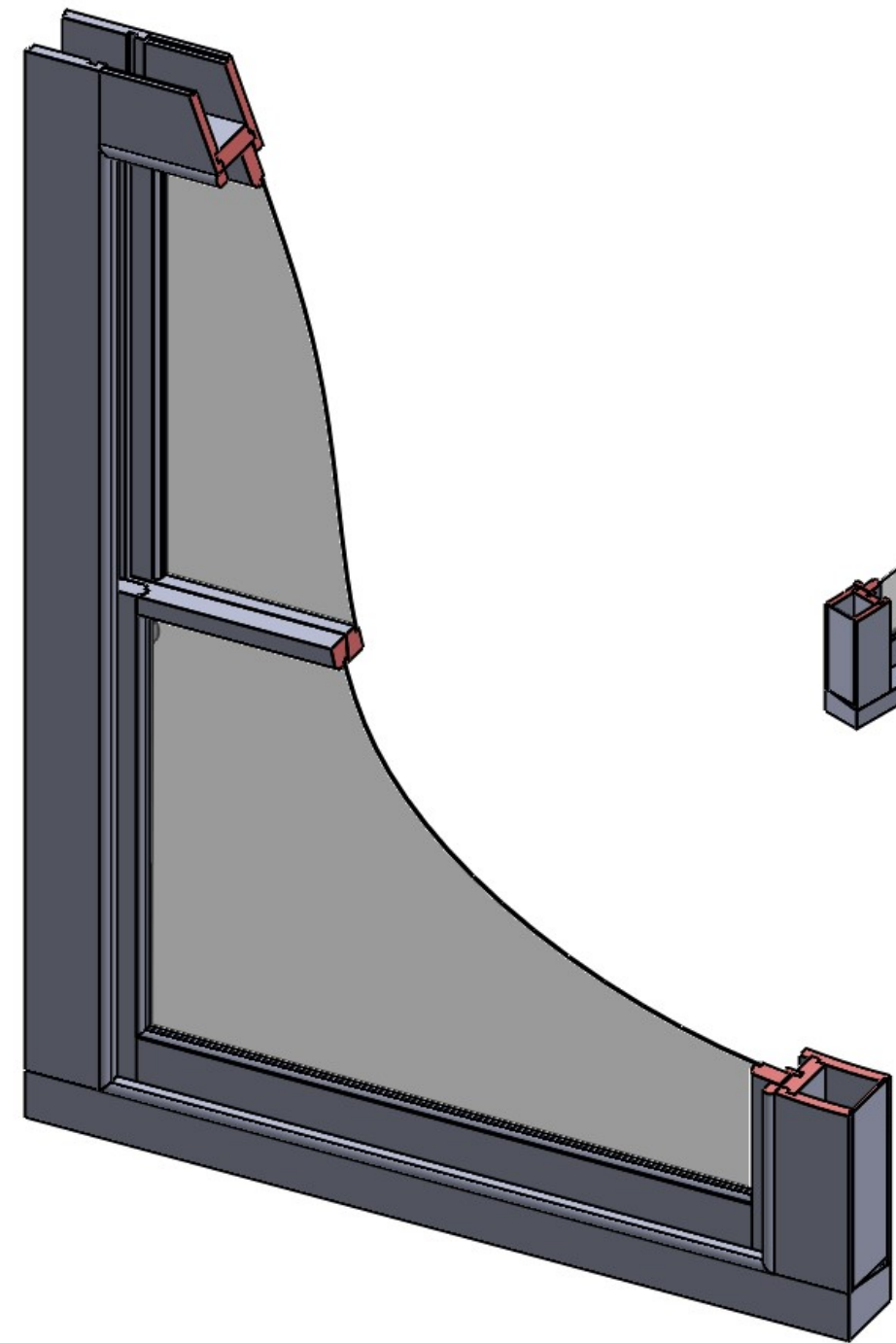

DETAIL C
SCALE 1 : 5

TYPE3 WSF4

REVISION HISTORY

REV A	Primary		
REV B	Box depth corrected		
REV C			
REV D			
REV E			

DO NOT SCALE THIS DRAWING, DWG'S AVAILABLE ON REQUEST.

ALL DIMENSIONS IN MM UNLESS OTHERWISE NOTED

	NAME	SIGNATURE	DATE
DRAWN BY:	HM		23 May 2023
LAST EDIT DATE:			
APPROVED BY:			

DRAWING ISSUE STATUS:

MATERIAL:	FINISH:	SHEET SIZE A3
-----------	---------	------------------

CUSTOMER: Studiolet

PROJECT: 64-65 Guilford Street

TITLE:
Existing windows
Type3

DWG NO. ST-GU-183	REVISION B	THIRD ANGLE PROJECTION
----------------------	---------------	------------------------

IMPORTANT INFORMATION:

- DO NOT SCALE THIS DRAWING, DRAWINGS AVAILABLE ON REQUEST.
- ALL DIMENSIONS ARE IN MILLIMETRES, UNLESS OTHERWISE STATED.
- THIS DRAWING IS CONFIDENTIAL AND THE COPYRIGHT IS VESTED IN STUDIOLET LTD.
- IT MUST NOT BE COPIED, LENT OR DISCLOSED TO A THIRD PARTY, WITHOUT THE WRITTEN CONSENT OF STUDIOLET LTD.
- IT IS SUBJECT TO RECALL & REVISION CONTROL.

NOTES: **Studiolet Ltd**
26 Cleveland Gardens, London W2 6DE

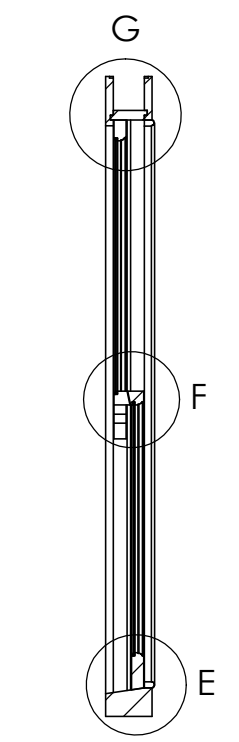
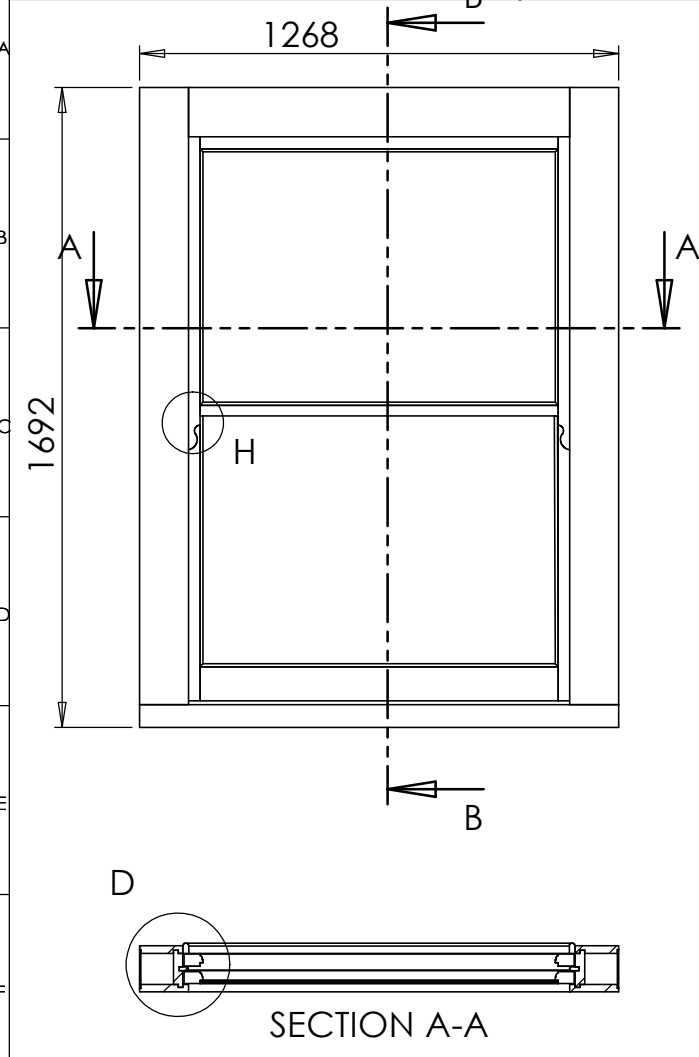

SECTION B-B



SECTION A-A

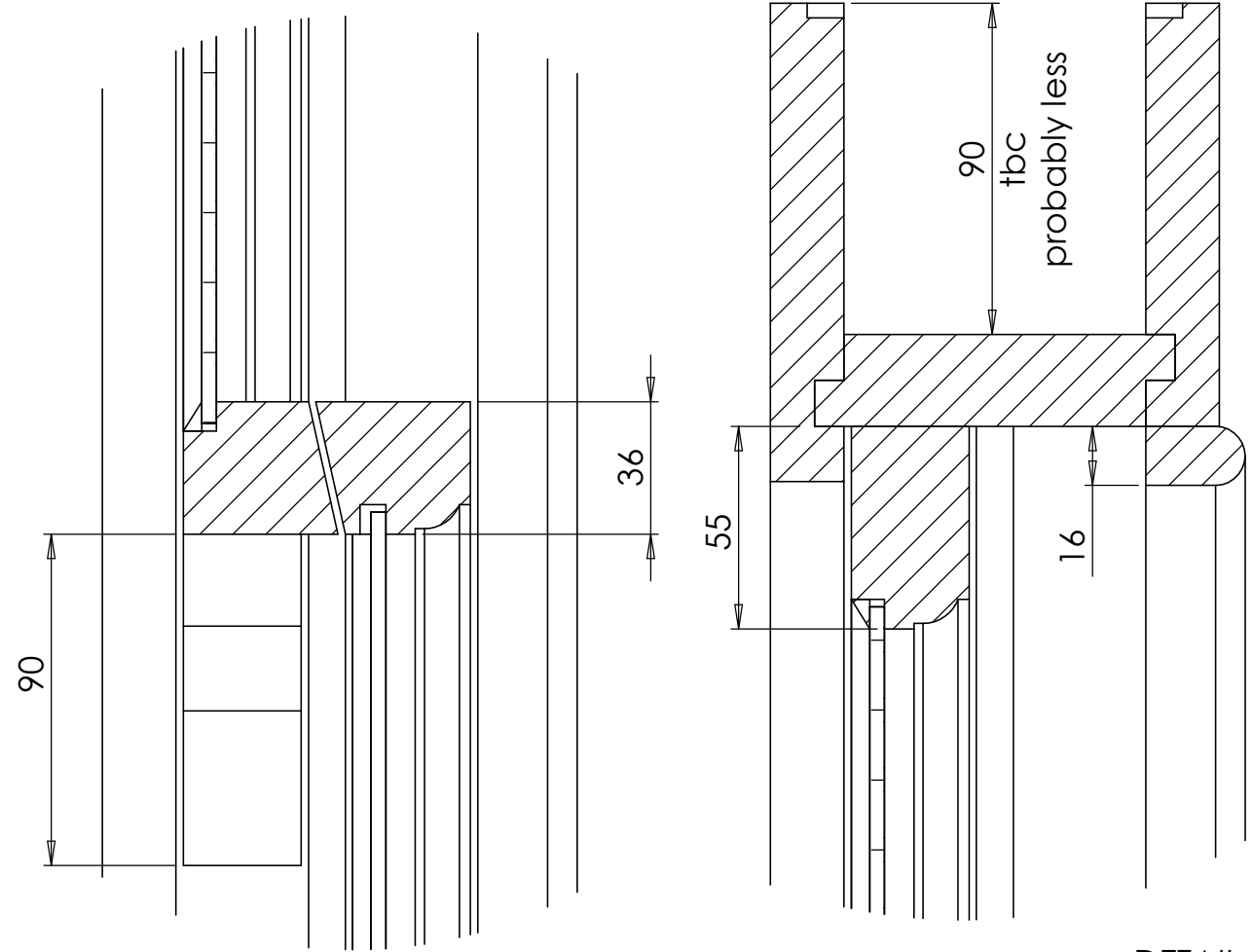

DETAIL F
SCALE 1 : 2

DETAIL G
SCALE 1 : 2

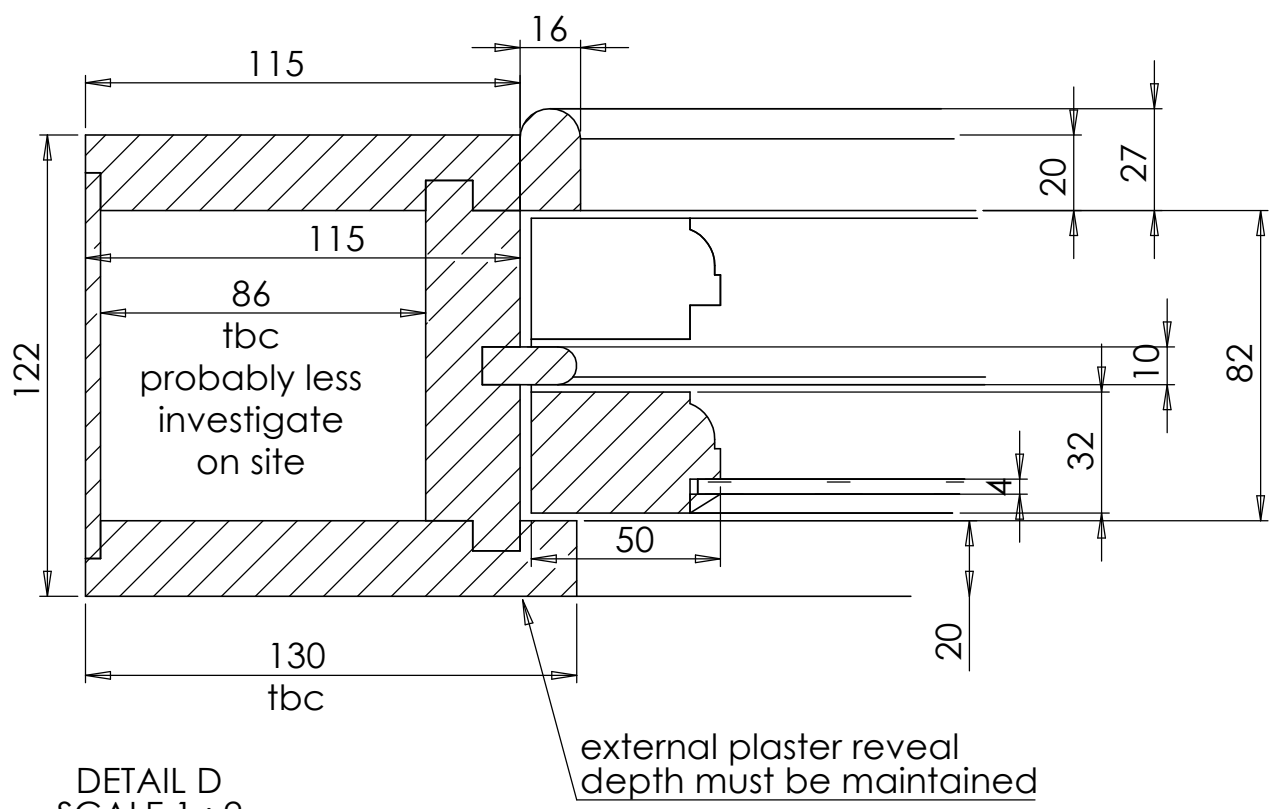

DETAIL D
SCALE 1 : 2

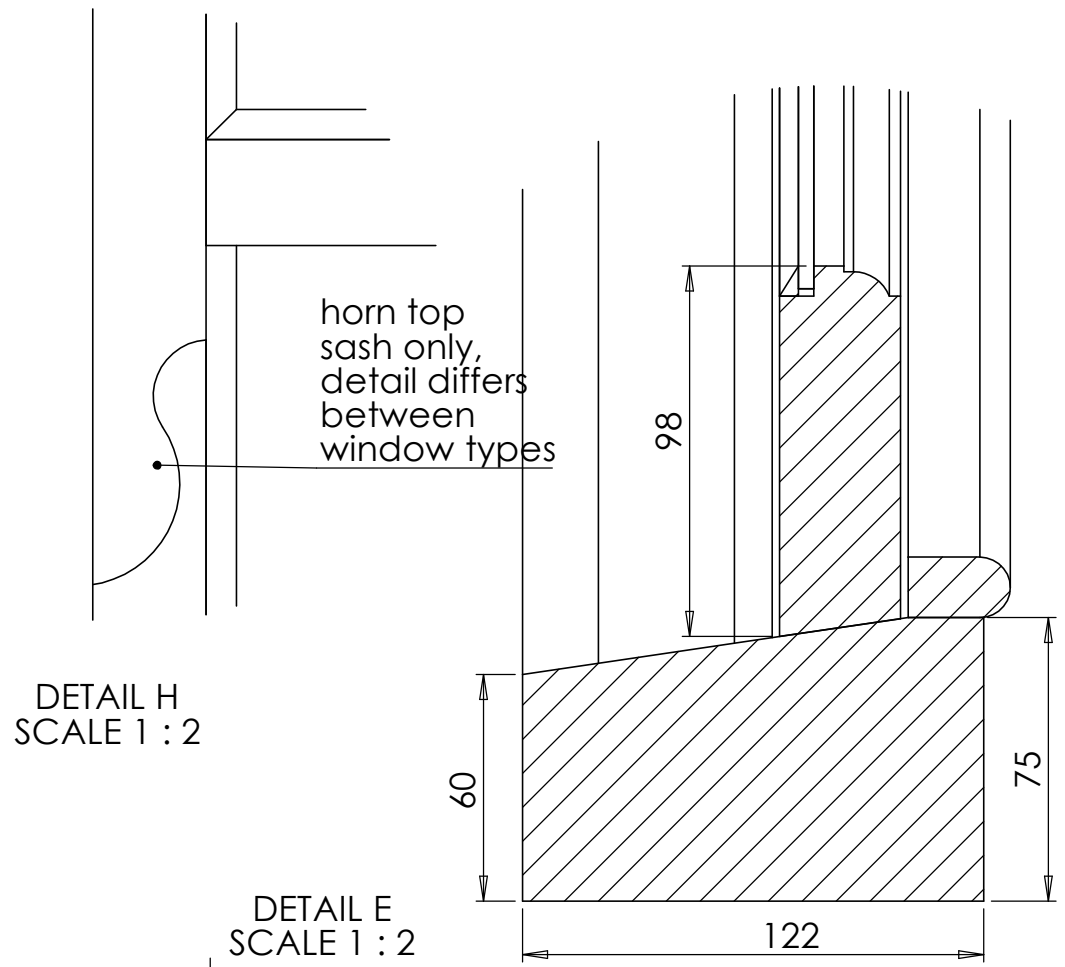

DETAIL H
SCALE 1 : 2

DETAIL E
SCALE 1 : 2

TYPE3 WSF4

REVISION HISTORY			
REV A	Primary		
REV B	Box depth corrected		
REV C			
REV D			
REV E			

DO NOT SCALE THIS DRAWING, DWG'S AVAILABLE ON REQUEST.
ALL DIMENSIONS IN MM UNLESS OTHERWISE NOTED

	NAME	SIGNATURE	DATE
DRAWN BY:	HM		23 May 2023
LAST EDIT DATE:			
APPROVED BY:			

DRAWING ISSUE STATUS:		
MATERIAL:	FINISH:	SHEET SIZE A3

CUSTOMER: Studiolet
PROJECT: 64-65 Guilford Street

TITLE:
Existing windows
Type3

DWG NO. ST-GU-183	REVISION B	THIRD ANGLE PROJECTION SHEET 1 OF 2
----------------------	---------------	--