

D01_Window Head

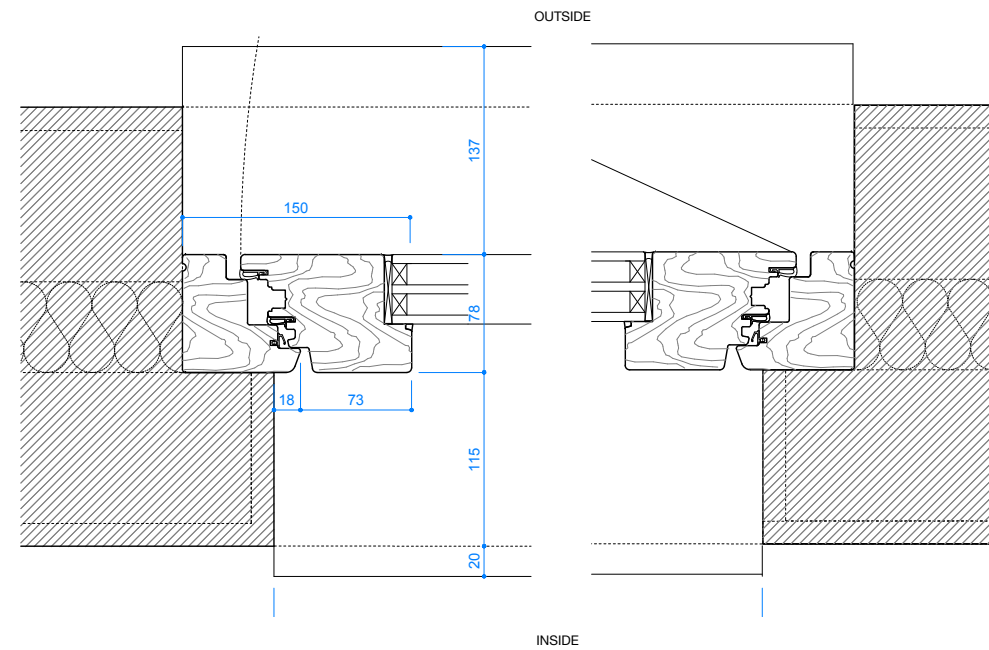

D03_Window Jamb

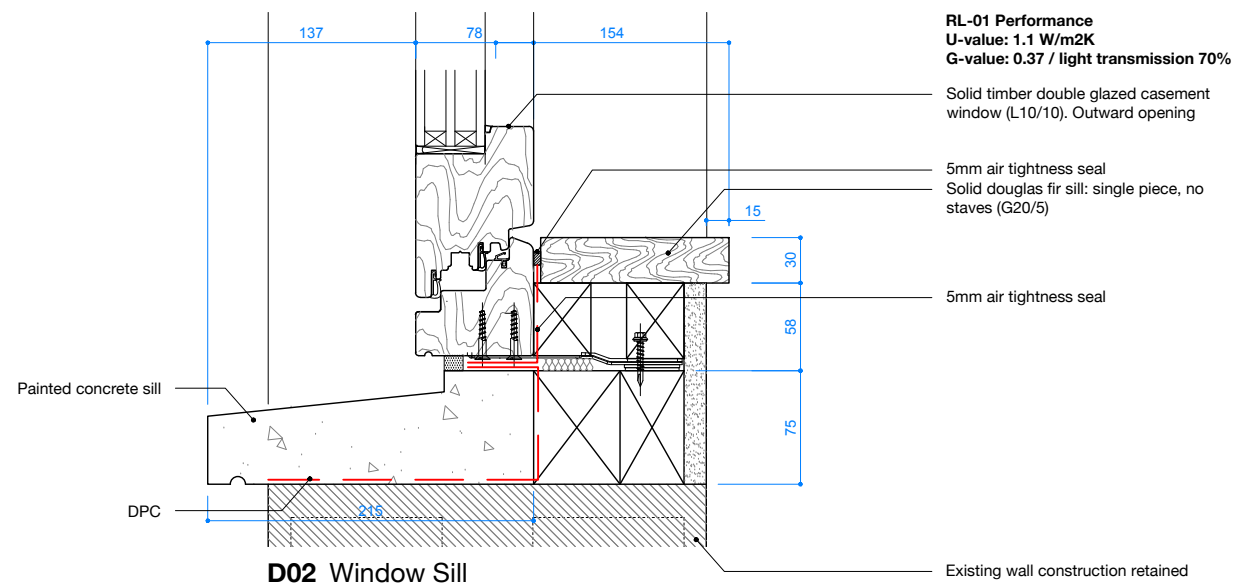

D02_Window Sill

- Notes**
- Do not scale drawings
 - All dimensions in mm
 - Errors to be reported immediately to the Designer
 - To be read in conjunction with all the relevant Designers' and Engineers' drawings
 - All dimensions to be checked and verified on site before proceeding
 - Structure shown is indicative only; for structural layouts / details refer to Engineers' drawings

Rev	Revision Notes	Date
-----	----------------	------

CB A
Clementine Blakemore
Architects

clem@clementineblakemore.com
+44 (0)7580 193709
157 Middleton Road, London E8 4LL

PROJECT NAME	PROJECT NO.
4 Leverton Street	013

PROJECT ADDRESS
4 Leverton Street, London NW5 2PJ

RIBA STAGE	PLANNING CONDITIONS
05	

DRAWN BY	CHECKED BY	SCALE
PF	CB	1:5

TITLE
Doors & Window Details 02

DATE	DRAWING NO.	REVISION NO.
26.09.2023	4LS - 411	P1