

Notes
 DO NOT SCALE THIS DRAWING UNLESS USED FOR PLANNING PURPOSES. USE FIGURED DIMENSIONS ONLY. CONTRACTORS ARE RESPONSIBLE FOR TAKING AND CHECKING ONLY SITE DIMENSIONS.
 DESIGN COPYRIGHT IS VESTED IN THE ARCHITECT FROM WHOM CONSENT MUST BE OBTAINED FOR COPYING OR REPRODUCING THIS DRAWING.

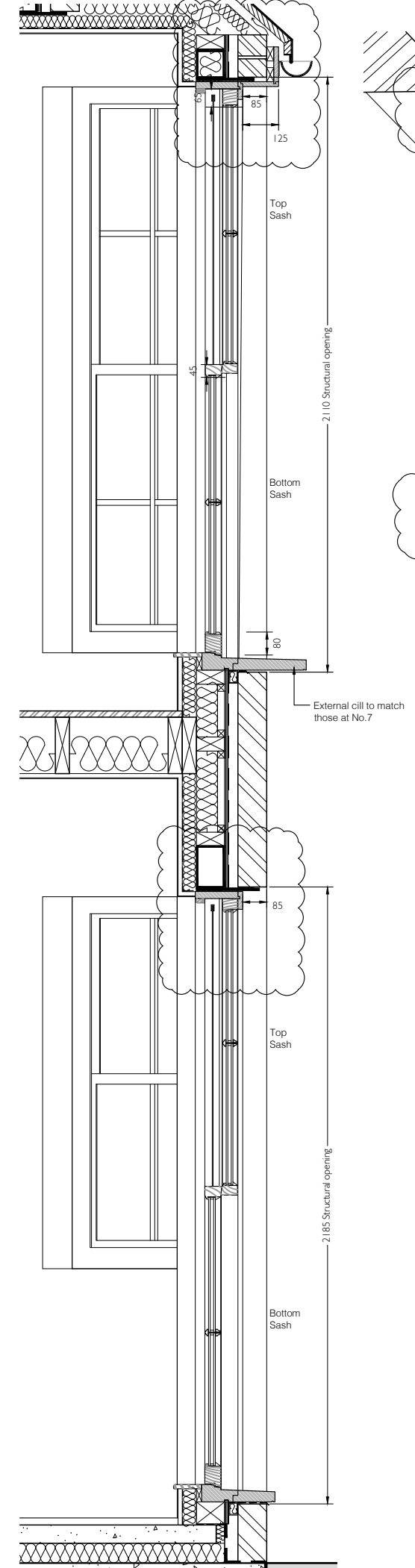

A PROPOSED FRONT ELEVATION
 PL-001



B PROPOSED SECTION
 PL-001

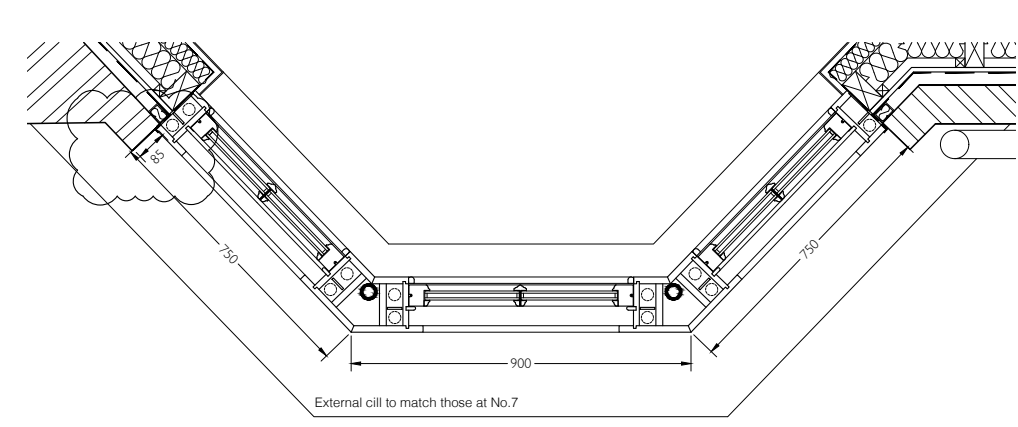

D PROPOSED UPPER GROUND FLOOR PLAN
 PL-001

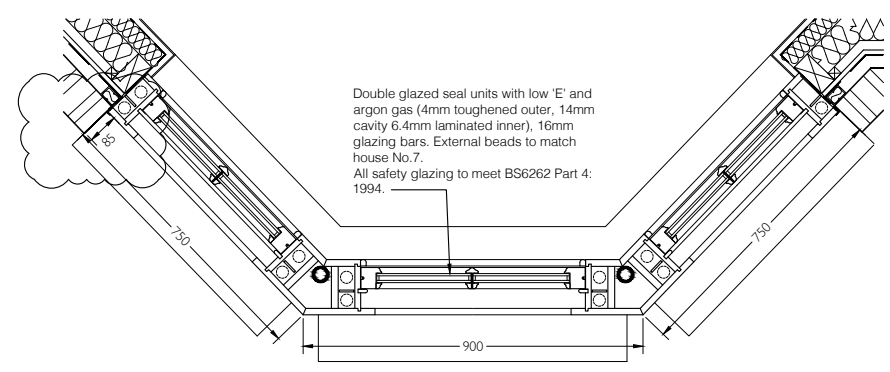

C PROPOSED LOWER GROUND FLOOR PLAN
 PL-001

Double glazed seal units with low 'E' and argon gas (4mm toughened outer, 14mm cavity 6.4mm laminated inner), 16mm glazing bars. External beads to match house No.7.
 All safety glazing to meet BS6262 Part 4: 1994.



E EXISTING BAY WINDOW AT No.7
 PL-001

Rev.	Date	Comment	By
B	10.07.23	WINDOW REVEALS INCREASED	/
A	20.06.23	HORIZONTAL GLAZING BARS SHOWN IN SECTION	/

Do not scale from this drawing unless used for planning purposes
 All dimensions are to be checked and confirmed on site
 Any discrepancies are to be reported immediately to the Architect or Main Contractor

COPYRIGHT © 2013
 ALL RIGHTS DESCRIBED IN THE CHAPTER IV OF THE COPYRIGHT DESIGN AND PATENTS ACT 1988, HAVE BEEN GENERALLY ASSERTED

Client
 Mr S Vogel
 5 Parkhill Road, London NW3 2YH

Project
5 Parkhill Road
 Planning - Discharge Condition

Drawing
 Front Window Details

Project No.	Drawing No.	Issue	Status
1457	PL-001	B	-

Scale Date Drawn By Checked By
 1:10 @ A1 Apr 23 JP

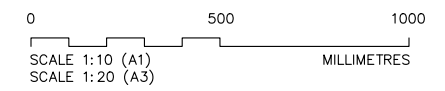

HP Architects
 (E) rickhase@hparchitects.uk
 (E) jaypresland@hparchitects.uk
 (W) www.hparchitects.uk