

PROGRAMME:

KEY:

	Neighbouring context	RWP	Rain Water Pipe
	Existing walls	SVP	Soil Vent Pipe
	Proposed walls		Boundary line
	Proposed rooflight		Existing removed
MH	Manhole		Existing beam
B	Boiler		1.2 m head height
EM	Electric Meter		1.5 m head height
GM	Gas Meter		Ridge line

REVISION NOTES:

REV:	DATE:	DESCRIPTION:
------	-------	--------------

- GENERAL NOTES:
- All Dimensions are in millimetres unless otherwise stated
 - All work to be carried out in accordance with current building regulations and all relevant british standards/codes of practice.
 - The Contractor is responsible for the correct setting out of the works on site, all dimensions to be checked prior to fabrication of materials and commencement of works.
 - This Drawing is to be read in conjunction with all relevant drawings and specifications
 - Exact SVP and Boiler position to be determined onsite by contractor
 - A 'macerator toilet' would be required for a certain designs if the toilet location is away from existing SVP
 - Steels imbedded into ceiling may be charged additionally by your contractor
 - All proposed materials are to be similar in appearance to that of the existing house, unless otherwise stated.
 - Skylights must not protrude past the roof slope by more than 150mm
 - Glazing which exceeds 25% of the added floor area will result in extra charges for S.A.P Calculations
 - Windows on a side elevation at first floor level or above must be obscured glazing and non openable below 1.7m
 - Load-bearing partitions and/or posts are shown in a rough position. The exact position is to be confirmed by a structural engineer prior to construction.

Rooflights - Pitched

1 : 20

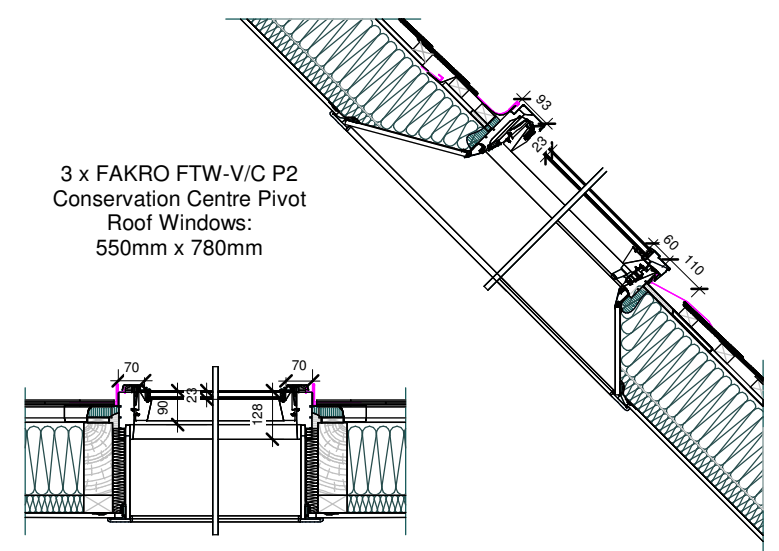

3 x FAKRO FTW-V/C P2
Conservation Centre Pivot
Roof Windows:
550mm x 780mm



FREEDOM HOMES

Freedom Homes, Ealing Cross, 85 Uxbridge Rd, London W5 5BW

CLIENT: Ina Burgstaller

PROJECT: Changes to fenestration

2B Tanza Road
NW3 2UB

PROJECT ADDRESS:

PROPOSED SECTIONS

DRAWING TITLE:

DRAWN BY: FH | CHECKED BY: JH

DATE: 24.05.2023 | Rev: 02 | Rev. DATE: 01.08.2023

SCALE@A3: 1:100 | DRAWING No: TR-R02-PR-106

