



Technical Submittal

Project Name: RFH - Fourth Floor East Chiller
Project Number: 001-00-421879 (402 East)
Date: 06/02/23



Ellis Building Services Ltd

Cornwallis House
Howard Chase
Basildon
Essex
SS14 3BB

For the attention of: James Ellis

Project Ref: RFH - Fourth Floor ICU Chiller Replacement

Our Ref: 001-00-421879 (402 East)

Date: 6th Feb 2023

Dear James,

We thank you for your order of 1 No. TRANE CGAF 060 XE XLN Low Noise Air Cooled Scroll Compressor Chiller operating with Low GWP Refrigerant R454b

We would advise that refrigerant R454b has a GWP of only 466 and is the lowest in the industry for Scroll Compressor units of this type. R454b has a GWP which is 76% lower than R410a and 34% lower than R32 making it an excellent choice for your client and the environment.

Please call us on 0845 7165162 with any questions you may have concerning this proposal. Thank you for considering TRANE products, we look forward to discussing our proposal further.

Yours faithfully,

James Prosser
TRANE UK

Equipment Sales Engineer

Name: James Prosser

E-mail: james.prosser@trane.com

Tel: 07938868180

Technical Support

Name: Akram Syed

E-mail: akram.syed@tranetechnologies.com

Tel: 07801 633033

Inclusions for CGAF Unit

Category Description	Option Description
<i>Unit model</i>	<i>CGAF air cooled scroll</i>
<i>Unit size</i>	<i>060</i>
<i>Electrical supply</i>	<i>400V/50Hz/3Ph</i>
<i>Efficiency level</i>	<i>eXtra efficiency (XE)</i>
<i>Agency listing</i>	<i>CE Marking</i>
<i>Pressure vessel code</i>	<i>PED (Pressure Equipment Directive)</i>
<i>Acoustic level</i>	<i>Extra low noise (XLN)</i>
<i>Operating map: airside</i>	<i>Low ambient for chillers</i>
<i>Water connection</i>	<i>Grooved pipe + Weld couplings</i>
<i>Operating map: water side</i>	<i>Comfort cooling (above -2C)</i>
<i>Evaporator Configurations</i>	<i>Brazed plates heat exchanger</i>
<i>Thermal insulation</i>	<i>Standard</i>
<i>Condenser & Free cooling Coil material</i>	<i>E-Coated MCHE</i>
Type of pump	Dual pump medium pressure
Smart flow control	Constant Speed Pump AFD Adjust
<i>Disconnect switch</i>	<i>Disconnect Switch</i>
<i>Human interface language</i>	<i>English</i>
<i>Smart com protocole</i>	<i>BACnet interface</i>
<i>Comm customer input/output</i>	<i>External set points & capacity outputs</i>
<i>Flow switch</i>	<i>Field installed flow switch (supplied loose)</i>
<i>Electrical IP protection</i>	<i>Enclosure with IP20 internal protection</i>
<i>Unit user interface</i>	<i>Standard, Local UI supplied</i>
<i>Unit isolator</i>	<i>Neoprene isolators (supplied loose)</i>
<i>Shipping package</i>	<i>Standard Protection</i>
Refrigerant Type	Full charge Low GWP R454B (GWP 466)
Power factor correction	Included to 0.95
<i>Freeze Protection (Factory Inst. Only)</i>	<i>Freeze protection for the BPHE</i>
Buffer Tank	With Tank
<i>Water Strainer</i>	<i>With</i>
<i>Starter Type</i>	<i>Solid State Soft Starter</i>
<i>Annunciation Relay</i>	<i>With</i>
<i>Fan type</i>	<i>EC fans</i>
<i>Delivery</i>	<i>Included</i>
<i>Commissioning</i>	<i>Included</i>



Guide Specifications

Sintesis™ Advantage

Air-to-water chillers

Model CGAF HE / XE

Sound versions SN / LN / XLN

192 - 265 kW

General

Chilled water production will be made by a factory-assembled and tested, air-cooled liquid chiller, Trane type CGAF XE XLN. Chiller will have two refrigerant circuits with two to three compressor per circuit, will be shipped with a full operating charge of HFC-based *R454B* refrigerant and lubrication oil, scroll compressors, brazed plate heat exchanger, with microprocessor-based control.

Documentation including installation-operation-maintenance manual, user guide, wiring diagram and submittal is placed in the control panel.

Quality assurance

Chiller is designed and manufactured under a quality assurance system and environmental management system certified in accordance with ISO 9001:2008 and ISO14001 standards.

Chiller is factory-tested according standard EN14511 (last revision), and performances are certified by Eurovent. All units are compliant with all applicable EU Ecodesign Regulations under the ErP framework Directive 2009/125/EC of the European Parliament.

All chillers follow a production quality plan to ensure proper construction and operation.

Unit construction will be in accordance with follow European directives (and following updates):

- Pressure Equipment Directive (PED) 97/23/CE
- Machinery Directive (MD) 2006/42/CE
- Low Voltage Directive (LV) 2006/95/CE
- ElectroMagnetic Compatibility Directive (EMC) 2004/108/CE
- Electrical Machinery Safety Standard EN 60204-1
- EcoDesign Directive 2009/125/CE

Construction Characteristics

Unit panels, frames and exposed steel surfaces will be constructed of galvanized steel, painted and have a corrosion resistance of 675 hours to salt spray test.

Electrical panel will be built of galvanized steel and rated IP54.

Compressors and Motors

The unit is equipped with two or more hermetic, direct-drive, 3000 rpm 50 Hz with Intermediate Discharge Valves (IDVs) scroll compressors. The Intermediate Discharge Valve adapts the energy consumption to the varying load and pressure conditions in the system.

Motor is suction gas cooled, hermetically sealed, two poles, squirrel cage induction type, with four pressure lubricated rolling elements, bearing groups shall support the rotating assembly. Motor bearings will be designed for the whole life of the chiller.

The compressor operating map allow condensing down to 10°C and up to 68°C saturated discharge temperature

Oil Management

The chiller is equipped with an oil management system without oil pump that ensures proper oil circulation throughout the unit. The key components of the system include an oil filter with particles retention capacity of at least 5µm.

An oil heater is installed to avoid startup with low oil temperature.

Evaporator

Braze plate heat exchanger is made of stainless steel with copper as the braze material. It is designed to withstand a refrigerant side working pressure of 44.5 bars and a waterside working pressure of 10.0 bars. Evaporator is tested at 1.1 times maximum allowable refrigerant side working pressure and 1.5 times maximum allowable water side working pressure. It has one water pass. Blanket heater secures the evaporator from freezing to an ambient of -20°C.

The evaporator is covered with factory-installed 0.75 inch (19.05 mm) Armaflex II or equal (k=0.28) insulation. Foam insulation is used on the suction line. Water pipe extensions with insulation go from the evaporator to the edge of the unit.

All evaporators are tested and stamped in accordance with PED.

Condenser and Fans

The air-cooled Microchannel condenser coils use all aluminum brazed fin construction. The coil is composed of three components: the flat microchannel tube, the fins located between the microchannel tubes, and two refrigerant manifolds.

Coils can be cleaned with high pressure water.

The condenser coil has an integral subcooling circuit. The maximum allowable working pressure of the condenser is 44.5 bars. Condensers are factory proof and leak tested at 45 bars.

Each condenser module is equipped with a refrigerant receiver in between the condenser section of the coil and the subcooler in order to balance the refrigerant charge for all operating conditions from -20°C for XE with Low ambient kit outdoor air temperature up to 48°C R454B units and for leaving water temperature from -12°C up to 20°C. The location in between the condensing and subcooling part of the condenser coil is to keep refrigerant subcooling to maximize the chiller efficiency at any operating conditions

Direct-drive vertical-discharge airfoil condenser fans are dynamically balanced. CGAF XE units mount electronic fans EC as a standard

Refrigerant Circuit

Each unit has two refrigerant circuits, with two to three scroll compressor per circuit. Each refrigerant circuit includes removable hardcore filter, charging port, and electronic expansion valve.

Electrical Panel

Single point connection with disconnect switch and circuit breaker on every motor.

The disconnect switch is mechanically interlocked to disconnect line power from the starter before the starter doors are open.

All components and control cables are numbered in accordance with CEI 60750.

A factory-installed, factory-wired control power transformer provides all unit control power and Symbio800 module power. All the starter elements are enclosed in an IP54 panel, with hinged door.

Trane Tracer Symbio™800 unit controller

All units are equipped with a Tracer Symbio™800 microprocessor-based controller which is factory-installed and factory-tested. The control system is powered by a control power transformer, provided with the unit.

Microprocessor-based chilled water reset based on return water is standard. The unit controller automatically takes action to prevent unit shutdown due to abnormal operating conditions associated with low evaporator refrigerant temperature, high condensing temperature, and motor current overload. If abnormal operating condition continues and protective limit is reached, the refrigerant circuit will be shut down.

Symbio™800 provides a flexible alarm or unit status indication to a remote location through a hard-wired interface to a dry contact closure. Four relays are available for this function.

Symbio™800 includes machine protection shutdown requiring manual reset for:

- Low evaporator refrigerant temperature and pressure
- High condenser refrigerant pressure
- Critical sensor or detection circuit fault
- High compressor discharge temperature
- High Suction temperature
- Communication lost between modules
- External and local emergency stop
- Loss of evaporator water flow
- Loss of BAS communication
- Electrical distribution faults

The above list is not exhaustive and only includes some of the most common diagnostics.

Several other key features are:

- Embedded schedule allows the controller to operate in stand-alone scheduled operation (without BMS)
- SD card for local back-up and peace of mind in case of equipment failures
- Expandable I/O which make the controller field programmable. This feature can reduce project costs and enables customized sequence of operations
- Optional WIFI module to enable wireless communication
- Remote connectivity: used in conjunction with Trane Connect, you can get equipment data at anytime, anywhere independently from the BMS system

Alarms and diagnostics

Over 100 diagnostic checks are made and are displayed when a fault is detected. The TD7 display indicates the fault, the type of reset required, the time and date the diagnostic occurred, the mode in which the machine was operating at the time of the diagnostic, and a help message. A diagnostic history displays the last 20 diagnostics with the time and date of their occurrence. Alarms and diagnostics are displayed in chronological order, with a color/symbol code: red octagon for immediate shutdown, yellow triangle for normal shutdown and blue circle for warning.

Communication and control sources

All necessary settings and setpoints are programmed into the microprocessor-based controller via the TD7 operator interface. The controller is capable of receiving signals simultaneously from a variety of control sources, in any combination, and priority order of control sources can be programmed.

The control source with priority determines active setpoints via the signal it sends to the control panel.
Optional WIFI module to enable wireless communication

Unit shall be able to support the following control sources:

- Local operator interface (standard)
- Hard-wired dry contact and 4-20 mA or 2-10 Vdc signal from an external source (interface optional; control source not supplied)
- Time of day scheduling (available from local operator interface)
- BACnet interface
- Modbus Interface
- Trane Tracer™ systems (interface optional; control source not supplied)

BACnet Interfaces

Symbio800 integrates build-in communication interfaces for BACnet MS/TP and BACnet IP.

The Building Automation and Control Network (BACnet and ANSI/ASHRAE Standard 135-2004) protocol is a standard that allows building automation systems or components from different manufacturers to share information and control functions. BACnet provides building owners the capability to connect various types of building control systems or subsystems together for a variety of reasons. In addition, multiple vendors can use this protocol to share information for monitoring and supervisory control between systems and devices in a multi-vendor interconnected system.

The BACnet interface identifies standard objects (data points) called BACnet objects.

Each object has a defined list of properties that provide information about that object. BACnet also defines a number of standard application services that are used to access data and manipulate these objects and provides a client/ server communication between devices. The Web UI is a good way to get all active BACnet points linked with the unit configuration. A complete BACnet detailed list is present in the BAS point list document.

BACnet Testing Laboratory (BTL) Certification

All Tracer Symbio™800 controllers are designed to support BACnet Smart Com Protocol.

ModBus Interfaces

Tracer Symbio™800 integrates build-in communication interfaces for Modbus RTU and Modbus TCP.

Modicon Communication Bus (Modbus) is an application layer-messaging protocol that, like BACnet, provides client/server communication between devices over a variety of networks. During communications on a Modbus network, the protocol determines how each controller will know its device address, recognize a message addressed to its device, determine what action to take, and extract any data or other information contained in the message.

Controllers communicate using a master/slave technique, whereby, only one device (master) can initiate transactions (queries). Other devices (slaves) respond by supplying the requested data to the master or by taking the action requested in the query.

The master can address individual slaves or it can initiate a broadcast message to all slaves. In turn, the slaves respond to queries that are addressed to them individually or broadcasted. The Modbus Interface establishes the format for the master's query by placing into it the device address, a function code defining the requested action, any data to be sent, and an error-checking field.

The Web UI is a good way to get all active Modbus points linked with the unit configuration.
A Modbus registers detailed list is present in the BAS point list document.

Trane TD7 user interface

Factory-mounted to the control panel door, the operator interface has a 7" LCD 16-bit color touch-screen display for operator input and information output. Display shall be UV-resistant and able to withstand ambient air temperatures between -40°C to 70°C.

This interface provides access to the following information: operating setpoints, evaporator report, condenser report, compressor report, operator settings, service settings, service tests, and diagnostics.

Additionally, the following data will be provided the reports:

- Water and air temperatures
- Refrigerant pressures and temperatures
- Flow switch status
- EXV position
- Compressor starts and run-time

The following ratings shall apply:

- IP56
- CE certification
- Emissions: EN55011(Class B)
- Immunity: EN61000 (Industrial)

Application

Low leaving water temperature

Low temperature option provides special control logic and oil cooler is installed to handle low temperature brine applications including part load conditions below 4.4°C (40°F) down to -12°C (10.4°F) leaving evaporator temperature.

Ice making mode

A wide range of leaving water temperature between -7°C and 20°C can be provided by the chiller. This option can be applied when the chiller is used to make ice at night.

Low ambient air temperature

The low ambient option adds unit controls to allow start and operation down to ambient temperatures of -20°C (-7.2°F). High side of ambient range remains at 48°C R454B

Integrated Variable Primary Flow

Integrated within the chiller controller, a variable primary flow option will allow control of the water flow through the evaporator. This will be based on a proven algorithm modulating the flow rate to minimize pump consumption at full and partial load. The operating modes available are the Constant Differential Temperature (DT) and Adjustable Fixed Speed:

- **Constant Differential Temperature (DT)**, in this case the chiller controller algorithm will maintain a constant difference in between entering and leaving temperature at the chiller plant (DT), regardless the load, reducing the water flow rate when necessary up to the minimum allowed. This solution can be applied on water loops with 3 way valve systems, and can deliver high energy in the majority of comfort applications.
- **Adjustable Fixed Speed**, in this case the pump is running at a fixed speed which can be set at a desired value through a drive

Partial Heat Recovery

Chiller can be supplied with a factory mounted brazed plate heat exchanger, fitted in series with condenser refrigerant circuit (2), in order to fulfill heat recovery from the compressor discharge (de-superheat) and partially from the condensing saturated temperature. On the water side of the heat recovery heat exchanger, hydraulic connection type Victaulic will be supplied. Heat to be recovered will be greater than 95% of the total compressor power input. Both BPHX will be connected in series on the water side, with temperature sensors in the water inlet and outlet, for monitoring purposes. The PHR HX will not have an impact on the cooling performances, and will allow production of hot water up to 55°C.

E-coating

An option to supply Micro Channel Heat Exchanger condenser coils with e-coating will be available. This e-coating will withstand the exposure to typical corrosive atmospheres, in shore or industrial locations, without sensible impact on coil performances in what heat transfer and air pressure drop is a concern.

Sound level

Extra low noise

Extra low noise units are equipped with a compressor sound box encapsulating all compressors with sound attenuation foam or enhanced compressor jacket, with equivalent noise reduction.

Hydraulic module option

The units is equipped with multiple hydraulic versions, characterized by complete kits of all major hydraulic components for an easier installation, with reduced time, cost and space. Hydraulic kit are available for ON-OFF and/or Inverter pumps. The wide range of hydraulic versions available make the unit suitable for any type of installation.

Different combination can be provided:

- 1 water pump (with Low / Medium / High available static pressure) , safety valve, relief valve, shut off valve, drain valves.
- 2 water pumps (with Low / Medium / High available static pressure) , safety valve, relief valve, check valves, shut off valves, drain valves.

All above combinations can be provided with or without water tank, 150 liters capacity.

Pump

The Centrifugal pumps have 2 poles, axial suction bowls and radial delivery; they have cast iron body and impeller entirely welded using laser technology. Mechanical seal with ceramic components, coal and EPDM elastomers. Three phase electric motor with IP55 protection and insulation class F, suitable for continuous service.

Series motors with higher efficiency IE3 technology

The automatic changeover is also available for double pump version. The pumps operate with the balance of the related working hours. In case of failure of one pump the controller in automatic switches on the additional pump. The control panel is equipped with fuses and contactor with thermal protection.

Buffer tank

This is made from black steel sheet. Finishing with anti-corrosion treatment and painting. The thermal and condensation insulation is protected by a water and scratch-resistant external coating. The test carried out individually with a test pressure of 9 bar guarantees a working pressure up to 3,5 bar.

Electrical options

- Under/over voltage protection
- Under/over voltage protection and ground fault protection
- Flow switch: the flow switch is sent as an accessory and must be installed on site.
- Across-the-Line Starter/Direct on Line: it is unit mounted with an IP-54 gasketed enclosure
- Solid-State Soft Starter: this option unit mounted starter has an IP-54 gasketed enclosure. To extend starter life contactors bypass current from the silicon control rectifies (SCRs) after startup
- Power factor correction capacitor : To reduce the reactive power and therefore the electrical current. Units have in average a $\cos\phi= 0,87$; thanks to this accessory it moves to ≥ 0.91
- Energy meter

Refrigerant leak detector

To detect a refrigerant leak, which avoids the risk of the flammability. To ensure safety for the customer by taking appropriate actions in the case of the leak. Refrigerant leak detector is available only on R454B units. A refrigerant detector is placed in the middle of the unit, close to the compressors

Freeze protection

Thanks to Symbio 800 controller, the anti-freeze protection is possible with the pump activation using external temperature sensor. As standard, all units are provided with an heater cable wrapped around the plate heat exchanger, under the insulation layer ; as an option all hydraulic circuit (pumps, pipes and tank) can be wrapped with an heating cable.

Control options

Master Slave

Simple hard wired solution to enable operation of slave unit when master unit reach maximum capacity. When the master is at his full capacity, there is activation of the slave like that the master can decompress and they regulate together.

Run test report

Run test report gives the results of the performance test of the unit in the design conditions specified in the order write-up with water without glycol.

The data recorded are: cooling capacity, power input, air temperature, water entering temperature, water leaving temperature and water flow.

Other Options

Coated condensing coils

Condensing coils are protected with a cathodic epoxy electrodeposition coating UV resistant

Unit isolators

Isolators provide isolation between chiller and structure to help eliminate vibration transmission and have an efficiency of 95% minimum. Neoprene or spring type are available.

Grooved pipe plus weld coupling

Grooved pipes are connected on water inlet and outlet. The coupling allows connection between the grooved pipe and the evaporator water connection.

Grooved pipe with coupling and flange adapter

Kit to convert both water connections from grooved pipe to flanged connections. This includes: grooved couplings, pipe offsets, and grooved to flange adapters.

Trane - by Trane Technologies (NYSE: TT), a global climate innovator - creates comfortable, energy efficient indoor environments for commercial and residential applications. For more information, please visit trane.eu or tranetechnologies.com.

Trane has a policy of continuous product and product data improvement and reserves the right to change design and specifications without notice.

Confidential and proprietary Trane information

CG-PRG017A-GB_0422
New

©2022 Trane



Installation Operation Maintenance

CGAF XE

Air-cooled chiller with scroll compressors and Symbio™ 800 controller with R454B refrigerant

CGAF XE - Cooling capacity 195 – 265 kW



Contents

OVERVIEW	3
SAFETY REGULATIONS	3
OPERATING LIMITS	7
INSTALLATION	9
ACOUSTIC PROTECTION	11
ELECTRICAL POWER SUPPLY	11
WATER CONNECTIONS	12
CGAF XE STANDARD REFRIGERANT SCHEMATIC	26
ELECTRICAL PANEL AND ELECTRICAL DATA	30
START-UP PRELIMINARY PROCEDURES	33
OPERATOR RESPONSABILITIES	33
CHECK LIST - MANDATORY OPERATION CONTROL BEFORE START-UP	34
START-UP	39
MAINTENANCE	42
RECOMMENDED SPARE PARTS	49

1 OVERVIEW

FOREWORD

These instructions are given as a guide to good practice in the installation, start-up, operation, and maintenance by the user of CGAF XE units. They do not contain full service procedures necessary for the continued successful operation of this equipment. The services of a qualified technician should be employed through the medium of a maintenance contract with a reputable service company. Read this manual thoroughly before unit start-up.

IMPORTANT:

As standard

- CGAF XE units mount electronic fans EC as a standard,

1.1 WARRANTY

A. The warranty for Trane machines is 12 months from the date the machine is operated for the first time but no more than 18 months from the date of the invoice. The warranty is reduced to 6 months from the start up date for units running continuously, that is more than 12 hours a day. The date the machine is operated for the first time means the date reported in the "1st start up form" contained into the "machine log book". This form should be filled in and sent, within 8 days from the start up, to Trane.

B. The warranty is valid if all the installation regulations have been adhered to (both those which may have come from Trane and those coming from current practice), if the "1st start up form" has been filled in and sent to the Trane after sales department.

C. The warranty is subject to any faults or defects being reported within eight days from their discovery. The warranty will only be applied if and when the purchaser suspends use of the equipment as soon as a defect has been found.

Replacement items are to be considered always ex TRANE factory. Labour costs to replace failed items either under warranty or not, will be not of TRANE care.

D. The warranty is valid if the first running of the machine is carried out by a Trane authorised assistance centre.

E. The warranty is subject to regular maintenance of the unit which is appropriately indicated in the "machine log book" located inside the electrical panel.

F. The warranty is automatically over in case of payments not fulfilled, non-performance of the contract and even if the units show tampering without TRANE writing approvals.

G. Non observance of the above mentioned rules and of all the indications written on this manual, will cause the immediate loss of warranty, getting free TRANE from any responsibility for the unit and any damages to persons or things.

1.2 RECEIVING THE UNIT

On receiving the unit, it is up to the customer to check that there is no obvious damage or pieces missing. If this is so, an immediate complaint must be made to the carrier for damage or for not-delivery. Photographic evidence must be provided for macroscopic damage. The card must be sent to Trane within 8 days of receiving the goods: if it is not sent back or delayed, the complaint will not be accepted.

1.3 FACTORY INSPECTION

Trane units are inspected into the factory, in appropriate areas, in accordance with internal procedures. Each performance test carried out on the unit is possible only if the same conditions are reproduced and maintained (charge consistency, constant temperature and evaporation - condensation and recovery capacity, quality and tolerance of the measuring instruments etc.) in the test rooms.

The inspection conditions are those indicated by the customer in the ordering phase: if not otherwise specified, reference should be made to the nominal performance indicated in the technical bulletin in force at the date of the Confirmation of the Order.

2 SAFETY REGULATIONS

All Trane units are designed, built and inspected in compliance with Pressure Equipment Directive (PED97/23/EC or 2014/68/EU and Machinery Directive 2006/42/EC.

2.1 DEFINITIONS

Owner:

The legal representative of the company, body or natural person who owns the plant in which the Trane unit is installed: he or she is responsible for the control and respect of all the safety regulations indicated in this manual

as well as the national ones in force.



Installer:

The legal representative of the company appointed by the owner to position and hydraulically, electrically etc. connect the Trane unit to the plant: he or she is responsible for moving and the correct installation of the unit in accordance with the indications in this manual and with the national regulations in force.

Operator:

A person authorized by the owner to carry out all the operations of regulation and control on the Trane unit which are specifically mentioned in this manual. He or she should keep to actions described in the manual and limit his or her action to what is explicitly allowed.

Technician:

A person who is directly authorized by Trane or, secondarily, for all EU countries except for Italy, by the distributor of the Trane product, under their own responsibility, to carry out all ordinary or extraordinary maintenance operations, as well as regulations, controls, repairs and parts replacement which may be necessary during the lifetime of the unit.

2.2 ACCESS TO DANGEROUS AREA

The access to the unit dangerous areas is usually obstructed through protection panels, which are removable, by using a tool. Axial fans are protected with accident prevention grilles.

For all the units which allow access to the cooling piping without security gratings (optional) or closing panelling, the following precautions must be taken:

- mark the areas with contact risks.
- apply warning signs.

The danger zone must be of a suitable size to avoid any contact, even accidental contact.

Trane declines any responsibility for damage to things and unauthorized personnel in case of absence of clear and static limiting systems of the risk areas and of the relevant warning and danger signs.

2.3 GENERAL PRECAUTIONS

The operator must only intervene on the unit commands; he or she must not open any panels except for the one which gives access to the command module.

The installer must only intervene on the connections between the plant and the machine; he or she must not open any machine panels nor carry out any commands.

The following precautions should be made when approaching or working on the unit:

- Do not wear jewelry, baggy clothes or any other accessory which can get caught up.
- Use appropriate protection (gloves, glasses etc.) when using an open flame (welding) or compressed air.
- If the unit is located in a closed environment, wear hearing protection.
- Before disconnecting, removing tubes, filters, joints or other line parts intercept the connection tubes, empty them until the pressure reaches that of the atmosphere.
- Do not use your hands to check for possible pressure losses.
- Always use tools which are in good condition; make sure the instructions have been fully understood before using them.
- Make sure that any tools, electrical cables or other loose objects have been removed before closing the unit and starting it up again.

2.4 PRECAUTIONS AGAINST RISKS DUE TO THE REFRIGERANT

Safety data	
Toxicity	Not important
Risks for skin touching	Splashes or sprinkles can cause chill burns. The risk of absorptions through the skin is not relevant.
	The R410a refrigerant could take some lightly irritating effects and in liquid stage it has a strong skinning effect. In this case it is necessary to rinse with fresh water the contaminated parts of the skin
Risks for contact with the eyes	The refrigerant in liquid stage in contact with wet fabrics cause freezing and adherence to the skin. In this case it is necessary to put off the contaminated clothes to avoid freezing. Please contact a doctor in case of irritation of the contaminated parts.
	Vapors don't take any effect. Splashes or sprinklers can cause chill burns. In those cases it is necessary to rinse the eyes with water or with solution for ocular washings for 10 minutes. The intervention of a doctor is needed.
Risks for ingestion	Should it happen, it causes chill burns. It does not cause vomiting. The person must be kept awake. It is needed to rinse the mouth with fresh water and to drink almost 0.25 liters. The intervention of a doctor is needed.

Risks for inhalation

High concentration of vapors in air can lead to anesthetic effects up to a loss of conscience. Long exposures could give rise to cardiac arrhythmia and sometimes even to death.

High concentrations can create a reduction of oxygen in air, with consequent possibility of suffocation. Should it happen the person must be taken to the open air and let him take a rest.

	Administer oxygen if needed. In case the breathing has interrupted or become irregular, it is necessary to apply the artificial breathing. In case of cardiac arrest a heart massage must be applied. Contact a doctor immediately.
Conditions to avoid	Use in presence of exposed flames, and of high levels of humidity.
Dangerous reactions	Possibility of violent reactions with the sodium, the potassium, the barium and with other alkaline substances, incompatible materials and all the alloys containing more than 2% of magnesium.
Protection wearing - Behavior in case of losses or escapes	Wear protection apparel and self-rescuer respirators. Insulate the source of the loss, if this operation can be done in safety conditions. Small quantitative of refrigerant escaped at liquid state can be allowed to evaporate only if the room is well ventilated. In case of great losses ventilate the room immediately. Plug the loss with sand, soil or other absorbent material; avoid that the liquid refrigerant can enter in water-drainages or losing pools.
Dismantlement	The best procedure is the recovery and the recycle. If this is not possible the refrigerant must be conferred to an accredited system for its destruction in order to neutralize acid and toxic by-products.

2.5 PRECAUTIONS AGAINST RESIDUAL RISKS

Prevention from risks due to the command system

- make sure the instructions for use have been understood before carrying out any work on the control panel.
- always keep the instruction manual close at hand when working on the control panel.
- start up the unit only after having certified that it is correctly connected to the plant.
- inform the technician promptly of any alarms which appear on the unit.
- do not reset the alarms to manual restart without having first identified the cause and removed it.

2.6 PREVENTION AGAINST RESIDUAL MECHANICAL RISKS

- install the unit in accordance with the provisions of the following manual.
- carry out all the maintenance operations provided for by this manual regularly.
- wear a protective helmet before entering inside the unit.
- before opening a machine panel make sure that it is firmly connected by means of a hinge.
- do not touch the air condensation batteries without having first put on protective gloves.
- do not remove the protections to the moving parts while the unit is running.
- before restarting the unit make sure that the moving part protections are in the correct position.

2.7 PREVENTION AGAINST RESIDUAL ELECTRICAL RISKS

- connect the unit to the mains in accordance with the provisions of this manual.
- carry out all maintenance operations regularly.
- before opening the control panel or access any electrical component installed on the unit disconnect the unit from the mains by means of the main switch.

It must be taken into account especially that when soft starters instead of contactors are installed as compressors drives, one phase of any compressor remains live when the compressor is off but the main switch is closed. Do not access the compressor electrical box.

- check that the unit has been earthen correctly before starting it up.
- control all the electrical connections and the connection cables paying particular attention to the state of isolation; replace the cables which are clearly worn or damaged.
- carry out periodic checks of the wiring inside the panel.
- do not use cables with an inappropriate section or flying connections not even for a limited period or in an emergency.

2.8 PREVENTION AGAINST RESIDUAL RISKS OF A DIFFERENT NATURE

- the residual risks due to pressure are mainly coming from a failure of the safety devices. To prevent them it is necessary to check and replace them when required
- **the unit is equipped with high pressure safety valves which may relieve high pressure and high temperature refrigerant in close vicinity of the unit in case of an abnormal overpressure event. In order to prevent harm to people who might find themselves close to the unit, the installer should convey the escaped refrigerant by means of piping. The safety valves installed in the unit are equipped with a threaded connection that makes conveying easier.**

If a piping aimed at conveying refrigerant from safety valves, as described above, has not been installed by the installer, in order to protect from safety devices exhausting it is not allowed to remove the protections while the unit is in operation and to approach the unit without wearing the right protections. In case of accidental contact with refrigerant due to the safety valves exhaust it is necessary to follow the above indicated.

- carry out the plant connections to the unit by following the indications reported on the following manual and on the panels of the unit itself.

- if a part is disassembled, make sure that it is correctly reassembled before restarting the unit.
- do not touch the discharge line of the compressor, the compressor itself or any other tube or component which is inside the machine without putting on protective gloves.
- keep a fire extinguisher which is able to put out fires on electrical equipment near the machine.

In the event of fire either if it originates on the unit or near it make sure the power supply to the unit is promptly cut and that any person who might be near the unit at that moment is moved to a secure location

- on units installed inside, connect the refrigerant circuit shut off valve to a network of tubes which are able to lead the possible spillage of refrigerating fluid outside.
- eliminate any fluid loss inside or outside the unit.
- collect the discharge liquid and clean up any possible oil leakage.
- periodically clean the compressor casing of the accumulated dirt deposits.
- do not keep inflammable liquids near the unit.
- do not dispose of the refrigerant fluid and the lubricating oil in the environment.
- welding should only be carried out on empty tubes; do not approach the tubes containing refrigerant fluid with flames or other sources of heat.
- do not bend or strike tubes containing pressurized fluids.

2.9 PRECAUTIONS TO BE OBSERVED DURING MAINTENANCE OPERATIONS

Only authorised technicians may carry out maintenance operations. Before carrying out any maintenance the following must be performed:

- isolate the unit from the mains electricity by using the external knife switch.
- place a notice on the external knife switch which says “**do not use - maintenance in progress**”.
- make sure that any possible on-off commands are disabled.
- use appropriate safety equipment (helmet, isolating gloves, protective glasses, safety shoes etc.).

If measurements or controls must be carried out which require the machine to be running the following observations must be followed:

- operate with the electrical panel open for as short a time as is possible.
- close the electrical panel as soon as the individual measurement or control has been carried out.
- for units which are located outside, do not carry out interventions in dangerous atmospheric conditions such as rain, snow, fog etc.

The following precautions should also be taken at all times:

- never dispose of fluids contained in the refrigerant circuit into the environment.
- when replacing the electronic card always use appropriate equipment (extractor, anti-static bracelet, etc.).
- if a compressor, the evaporator, the condensation batteries or any other heavy part is to be replaced, make sure that the lifting equipment matches the weight to be lifted.
- if the unit has an independent compressor compartment, do not open the ventilator compartment without having first isolated the machine using the knife switch on the side of the panel and only after having placed a sign which says “do not use - maintenance in progress”.
- if modifications must be carried out to the cooling, hydraulic or electrical circuit of the unit, as well as to its command logic, contact Trane.
- if particularly complicated assembly or disassembly operations are to be carried out contact Trane.
- always use original spare parts bought directly from Trane or from official dealers of the companies reported in the list of recommended spare parts.
- if the unit is to be moved after a year of being in the site or if it has to be dismantled contact Trane.

2.10 MANUAL ALARM RESET

If there is an alarm the unit must not be manually reset before having located and eliminated the cause of the fault. Repeated manual resets may cause the warranty to be annulled.

3 OPERATING LIMITS

3.1 STORAGE

The units can be stored within the following environmental conditions:

Min ambient temperature	:	-10°C
Max ambient temperature	:	53°C
Max relative humidity	:	95% not condensable

CAUTION: The storage in a very high humidity space (condensation) can damage electronic components.

3.2 OPERATING LIMITS

CGAF XE unit operation is permitted within the limits indicated in the diagram provided in 3.3.

CAUTION: The operation outside the limits specified may cause the activation of the protections and disrupt the operation of the unit and, in extreme cases, damage the unit.
In case of doubt, consult the factory.

These operating limits apply to unit operating at full load.

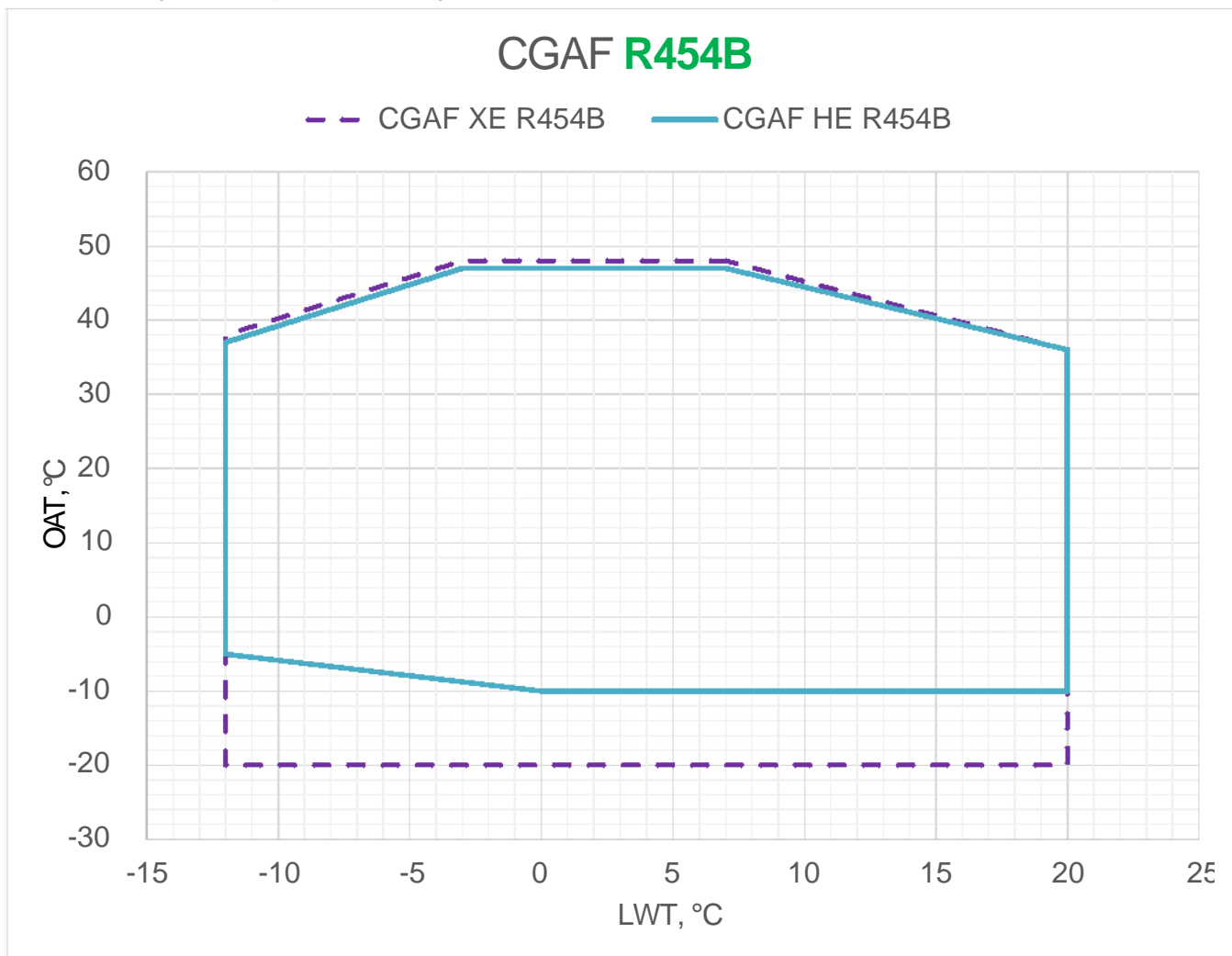

CGAF LOW AMBIENT KIT		
UNIT APPLICATION	Lower outdoor air Temperature, °C	Remark
Standard ambient	Down to -10°C	CGAF XE
Low ambient	Down to -20°C	Only for CGAF XE

ETHYLENE GLYCOL CORRECTION TABLE

% Ethylene glycol weight	10%	15%	20%	25%	30%	35%	
Lowest outlet water temperature	°C	4	2	0	-2,8	-6	-10
Suggested security limit	°C	1	-1	-4	-6	-10	-14
Cooling capacity coefficient	-	0,99	0,985	0,981	0,977	0,974	0,971
Power input coefficient	-	0,993	0,99	0,988	0,986	0,984	0,982
Flow rate coefficient	-	1,04	1,05	1,07	1,08	1,09	1,11
Pressure drop coefficient	-	1,11	1,17	1,23	1,31	1,39	1,47

In order to calculate performance with glycoled solutions multiply main sizes by respective coefficients.

GLYCOL PERCENTAGE DEPENDING ON FREEZING TEMPERATURE

		% glycol according to the freezing temperature				
Freezing temperature	0°C	-5°C	-10°C	-15°C	-20°C	-25°C
% Ethylene glycol		5%	12%	28%	35%	40%
Flow rate coefficient		1,02	1,04	1,09	1,11	1,13

In order to calculate performance with glycoled solutions multiply main sizes by respective coefficients.

4 INSTALLATION

4.1 MOVING AND POSITIONING THE UNIT

The units have been designed to be lifted from above by means of eyebolts and holes in the base members. Use retractor bars to keep the lifting wires or chains away from the unit.

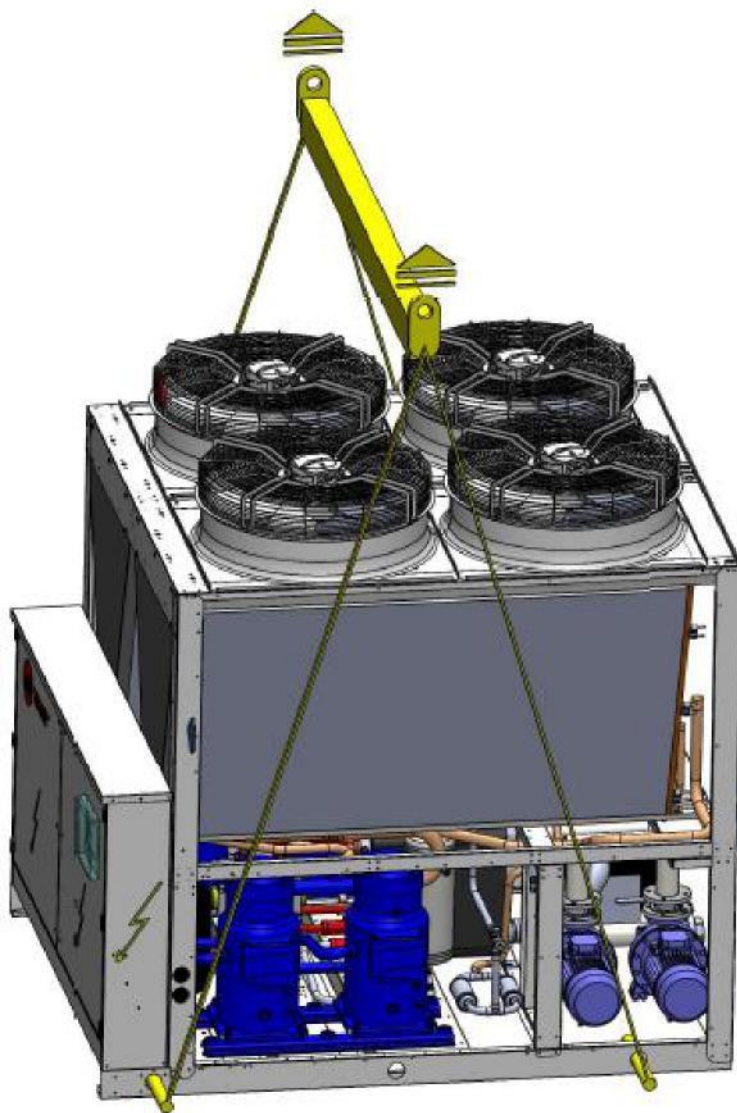

Figure 1: Correct lifting procedure

Lifting procedures provided with the unit have to be respected.

Attention

Do not use forklift trucks to lift the unit from below.

If equipment for lifting from above is not available, using rollers may move the unit.

The surface on which the unit is placed must be flat and strong enough to withstand the weight of the unit while running.

In order to reduce the transmission of vibrations to the supporting structures, fit shock absorbers in every fastening point. Rubber shock absorbers are recommended for units installed on the ground, spring shock absorbers for units installed on roofs. Open spaces around the unit must be provided for in order to allow for the passage of necessary airflow and in order to allow normal maintenance to be carried out (as shown on general catalogues).

IMPORTANT: Make sure that during transport the CGAF XE unit ALWAYS remains in the correct position!

Horizontal positioning of the unit can lead to irreversible damage to the compressors.

Damage arising from incorrect transport will not be under warranty by the manufacturer.

Immediately report an incorrect receipt of goods. An arrow positioned upward indicates the vertical position of the unit.

4.2 MINIMUM SPACE REQUIREMENTS

Dimensional drawing shall be respected to avoid:

- Noise
- Incorrect heat exchange and ventilation
- Difficult maintenance or inaccessibility to components
-

It is fundamental to respect minimum distances on all CGAF XE units, in order to ensure optimum ventilation for the condenser coils. Limited installation space could reduce the normal air flow, thus significantly reducing the unit performance and considerably increasing consumption of electrical energy.

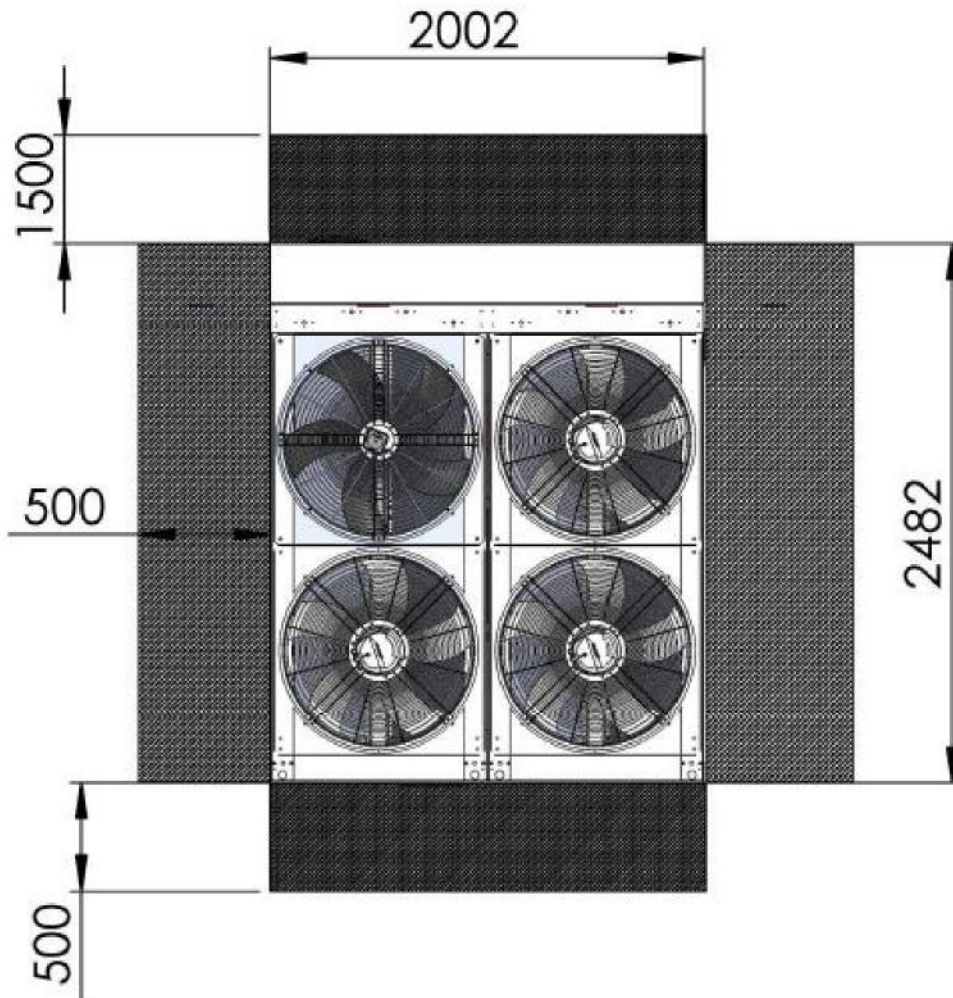

Figure 2: minimum space requirements [mm]

CAUTION: in case two units have to be installed side by side, the distance of respect must be doubled.

4.3 PRECAUTIONS FOR DOMINANT WINDS

Avoid obstacles on suction and discharge sides of the units. Respect the safety distances as shown on the units dimensional drawings.

In case of presence of dominant winds in the installation area it is strictly necessary to avoid (for units with horizontal flow fans) that such winds blow in front of the unit (fans discharge side). In case of unit with vertical flow fans it is strictly necessary to avoid installations where the dominant winds could cause rejected hot air to come back to the condensing coils.

4.4 PRECAUTIONS AGAINST DIRECT SUNSHINE

Direct solar radiation can raise the temperature of condensation until it causes the unit shutdown or failure start-up of the same by action of the high pressure switch

4.5 PRECAUTIONS AGAINST THE PRESENCE OF FIREPLACES AND EXHAUST HOT AIR

Avoid installation of the machines downwind of chimneys, smokestacks and different effluent discharges.

4.6 PRECAUTIONS AGAINST THE PRESENCE OF FOLIAGE AND FOREIGN BODIES

Avoid installing the unit in the immediate vicinity of plants that can prevent proper intake and discharge air.

4.7 CONTROL OF COMPRESSOR FASTENING

The compressors are fitted on shock absorbers. For fixing through spring anti-vibration mounts, it is necessary to remove blockages put to fasten the compressors, as indicated on the label on compressors body.

5 ACOUSTIC PROTECTION

When the sound level must be checked in particular, it is necessary to pay maximum WARNING in isolation from the base of the unit properly applying the anti-vibration mounts (provided optionally). Also, install flexible joints on water connections.

6 ELECTRICAL POWER SUPPLY

The mains power supply characteristics have to match the unit's absorption. The mains power supply tension must correspond to the nominal value $\pm 10\%$, with a maximum difference between the phases of 2%.

All power supply wiring must be sized and selected accordingly by the project engineer in accordance with standard IEC 60364. All wiring must comply with local code.

6.1 POWER CONNECTIONS

Protect the unit electric box power supply circuit with protection devices (not included in the supplied equipment). Connect the line terminals with a three-core cable of a section which is appropriate to the machine absorption. The switch and the fuses like all the power connections must comply with the regulations in force.

6.2 IMBALANCE BETWEEN THE SUPPLY TENSION PHASES

Do not run the electrical motors when the voltage unbalance between the phases is more than 2%. Use the following formula to check:

$$\% \text{ Imbalance} = [(V_x - V_{ave}) \times 100 / V_{ave}]$$

$$V_{ave} = (V_1 + V_2 + V_3) / 3$$

V_x = phase with greatest difference from V_{ave} (without regard to the sign)

IMPORTANT: If the mains voltage has an imbalance of above 2%, contact the company, which distributes the electrical energy. If the unit functions with **a unit voltage imbalance between the phases of above 2% the warranty is invalid.**

6.3 UNIT VOLTAGE PHASING

It is important that proper rotation of the compressors be established before the unit is started. Proper motor rotation requires confirmation of the electrical phase sequence of the power supply. The motor is internally connected for clockwise rotation with the incoming power supply phases A-B-C.



7 WATER CONNECTIONS

7.1 EVAPORATOR

The connection tubes have to be supported adequately in order that their weight does not damage the plant. It is necessary that the water flow rate to the unit is compatible with the evaporator one. It is also necessary that the water flow rate is kept uniform while the unit is running; it is suggested to use always a pump system dedicated to the unit and independent from the remaining part of the plant.

Before stalling units with temperature around 0°C please evacuate the exchanger with compressed air in order to avoid breakings due to ice.

If the unit is installed in order to replace another, the entire hydraulic system must be emptied and cleaned before the new unit is installed. Regular tests and proper chemical treatment of water are recommended before starting up the new unit.

In the event that glycol is added to the hydraulic system as anti-freeze protection, pay attention to the fact that intake pressure will be lower, the unit's performance will be lower and water pressure drops will be greater. All unit-protection methods, such as anti-freeze, and low-pressure protection will need to be reset. Before insulating water piping, check that there are no leaks.

CAUTION: Install a mechanical water filter at the water outlet of each heat exchanger. Failure to install the filter allows access of solid particles and / or welding slag inside the heat exchanger. We recommend the installation of a filter having a filtering net with holes not exceeding 0.5 mm in diameter.

Trane cannot be held responsible for any damage to heat exchangers due to the lack of good quality water filters.

Maximum operating pressure: 6 bar

7.1.1 Calculation of total recommended water content and flow rates

To grant a perfect running, the machine needs a water content according to the following values:

CGAF XE R454B	cold water production			
	V [m ³]	K	Q min [m ³ /h]	Q max [m ³ /h]
055	0.63	40	20.9	55.7
060	0.7	39.9	23.5	62.7
065	0.75	26.3	25.0	66.6
070	0.78	26.3	26.0	69.2
073	0.81	26.3	27.0	72.1
075	0.84	26.3	28.1	74.9

LEGEND:

V: recommended water content of the plant

Q min: minimum water flow to the heat exchanger

Q max: maximum water flow to the heat exchanger

$\Delta T_{\text{max chiller mode}} = 8 \text{ }^{\circ}\text{C}$

$dpw = K \cdot Q^2 / 1000 \text{ } Q = 0,86 P / \Delta T$

IMPORTANT: In case the water pump is driven by an inverter (either an on-board pump or an external pump) make sure that in every working condition the variation of the water flow rate must be as low as possible. Flow rate variation must be less than 10% of the nominal flow rate per minute



WATER TREATMENT

Before putting the unit into operation, clean the hydraulic circuit. Dirt, scales, corrosion residue and other extraneous material can accumulate inside the heat exchanger and reduce its heat exchanging capacity. Pressure drops can increase, as well, thus reducing water flow. Proper water treatment therefore reduces the risk of corrosion, erosion, scaling, etc. The most appropriate water treatment must be determined locally, according to the type of system and to the local characteristics of the process water.

Trane is not responsible for damage to or malfunctioning of equipment caused by failure to treat water or by improperly treated water.

Acceptable water quality limits

PH (25°C)	6,8÷8,0	Total Hardness (m g CaCO ₃ / l)	< 200
Electrical conductivity S/cm (25°C)	< 800	Iron (mg Fe / l)	< 1.0
Chloride ion (mg Cl - / l)	< 200	Sulfur ion (mg S ²⁻ / l)	None
Sulphate ion (mg SO ₄ ²⁻ / l)	< 200	Ammonium ion (mg NH ₄ ⁺ / l)	< 1.0
Alkalinity (mg CaCO ₃ / l)	< 100	Silica (mg SiO ₂ / l)	< 50

7.2 PRECAUTION AGAINST FROST RISK OF THE HYDRAULIC PIPES

It is necessary to insulate pipes in the plant to avoid extreme heat loss and to protect them from weather conditions. The problem of water pipes freezing could appear in two different situations:

1. Stand by, with mode on, but electrically connected: in this case, the unit has frost resistances, which protect the water locally contained in the exchangers and in the pipes from ice formation. These resistances do not ensure the protection against the frost in the outdoor connection pipes, to be prevented by frost protection systems. Trane suggest to insert frost thermostatic resistances on every outdoor pipes. In the following table there are the indicative electric powers per pipe linear meter

Heating cable required power

dn	inch	W / m
8	1/4"	5
10	3/8"	5
15	1/2"	5
20	3/4"	10
25	1"	13
40	1" 1/2	30
50	2"	50
65	2" 1/2	80
80	3"	120
100	4"	200
125	5"	300
150	6"	450

2. Electrically unconnected unit: in this case the frost resistances of the unit could not ensure the protection. It is necessary to add the correct glycol quantity indicated in the chapter: "ethylene glycol correction table" (§3.3). Please consult Trane service for % of glycol required.

7.2.1 Precaution for very low outdoor temperatures

In case of installation conditions with a very low temperature:

1. If there is a storage on board the unit, insert electric resistances to be calculated by:
 $PrWatt = V \times (10 - t_{min}) / 860$
where: *PrWatt* is the resistance power (Watt) and *tmin* is the lower temperature (°C)
2. If there is no storage, maintain the water temperature higher than 10°C by inserting thermostatic resistance with power calculated as in case 1.

7.3 ANTIFREEZE PROTECTION ON THE HEAT EXCHANGER

Two or more protection methods should be foreseen when designing the system as a whole:

1. Continuous water flow circulation inside piping and exchanger when ambient air temperature is holding below 5 °C. This implies what follows:

- if the water flow inside piping and exchanger of the unit is due to an external pump installed by the customer, the on/off command of this pump must always be the one provided by the unit controller through the relevant free potential contact in the electrical cabinet.
- as long as the ambient air temperature is holding below 5 °C the unit must always be electrically supplied. Moreover the customer pump, if present, must always be electrically supplied alike and functioning properly.

2. Addition of an appropriate amount of glycol inside the water circuit.

3. Additional heat insulation and sufficient heating of exposed piping.

IMPORTANT: Trane can provide various optional kits (they are not included in the Low ambient kit down to -10°C) for the protection of all the components of the hydraulic circuit inside the unit (pumps, pipes and tank). For a proper selection and price please contact your local Trane Sales & Service office.

4. Emptying and cleaning of the heat exchanger during the winter season.

It is the responsibility of the installer and/or of local maintenance personnel to ensure two or more of the described antifreeze methods. Continuously verify, through routine checks, that appropriate anti-freeze protection is maintained. Failure to follow the instructions above could result in damage to some of the unit's components. Damage from freezing is not covered by the warranty.

CAUTION: The unit water pipes are not protected against the risk of water freeze-up when the unit is not electrically powered and when the power and control of the external water pumps is not managed by the CGAF XE unit controller. The owner or local maintenance personnel must provide appropriate solutions to prevent freezing.

7.4 HYDRAULIC VERSIONS

CGAF XE units are available in four hydraulic versions characterized by complete kits of all major hydraulic components for an easier installation, with reduced time, cost and space.

- single pump
- single pump and tank
- double pump
- double pump and tank

Hydronic accessories on request

- "Y" water strainer (sold separately), consists of body and stainless steel mesh, with replaceable filter through the inspection cap.
- Automatic water filling (sold separately).
- Water antifreeze protection kits
- Water gauges kit

*) Water strainer with meshes not over 0.5mm

IMPORTANT: water strainer and flow switch must be installed on water circuit (user side) to keep the warranty. No water flow control device is installed on the unit so, the flow switch is always provided as a loose accessory (optional) and must be installed by the customer.

7.4.1 Water antifreeze protection kits

These kits, aimed at avoiding the freezing of all the components of the hydraulic circuit inside the unit (pumps, pipes and tank) are optional and are coupled to the unit hydraulic versions.

The heating cable type used for the kits mentioned above is featured in the figure below (in figure is shown 230 V version):

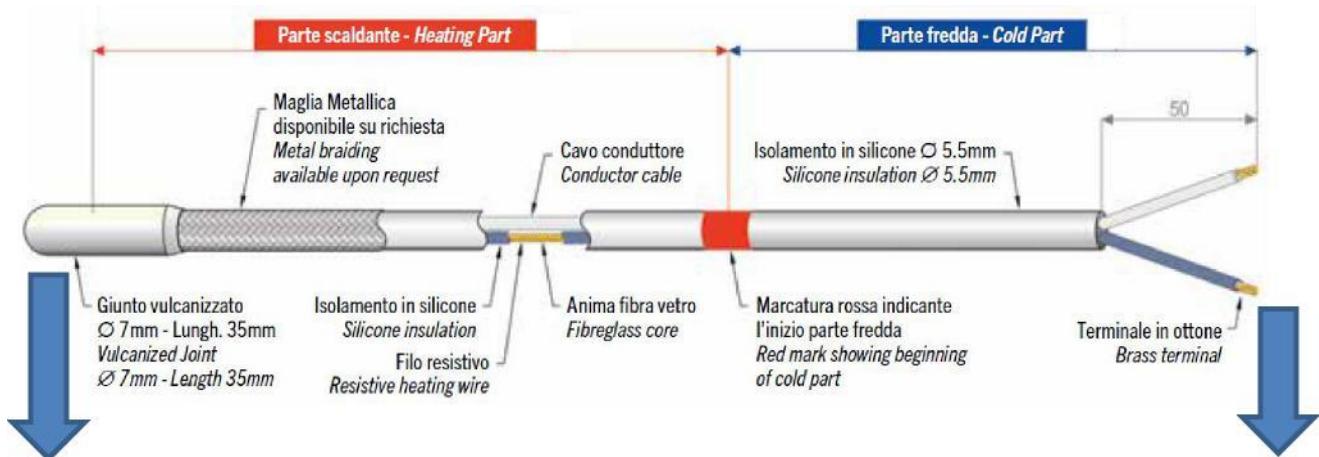

Hot part wound around the element
(pump, tank or pipe) to be heated

Cold part connected to the terminal
board in the electrical cabinet

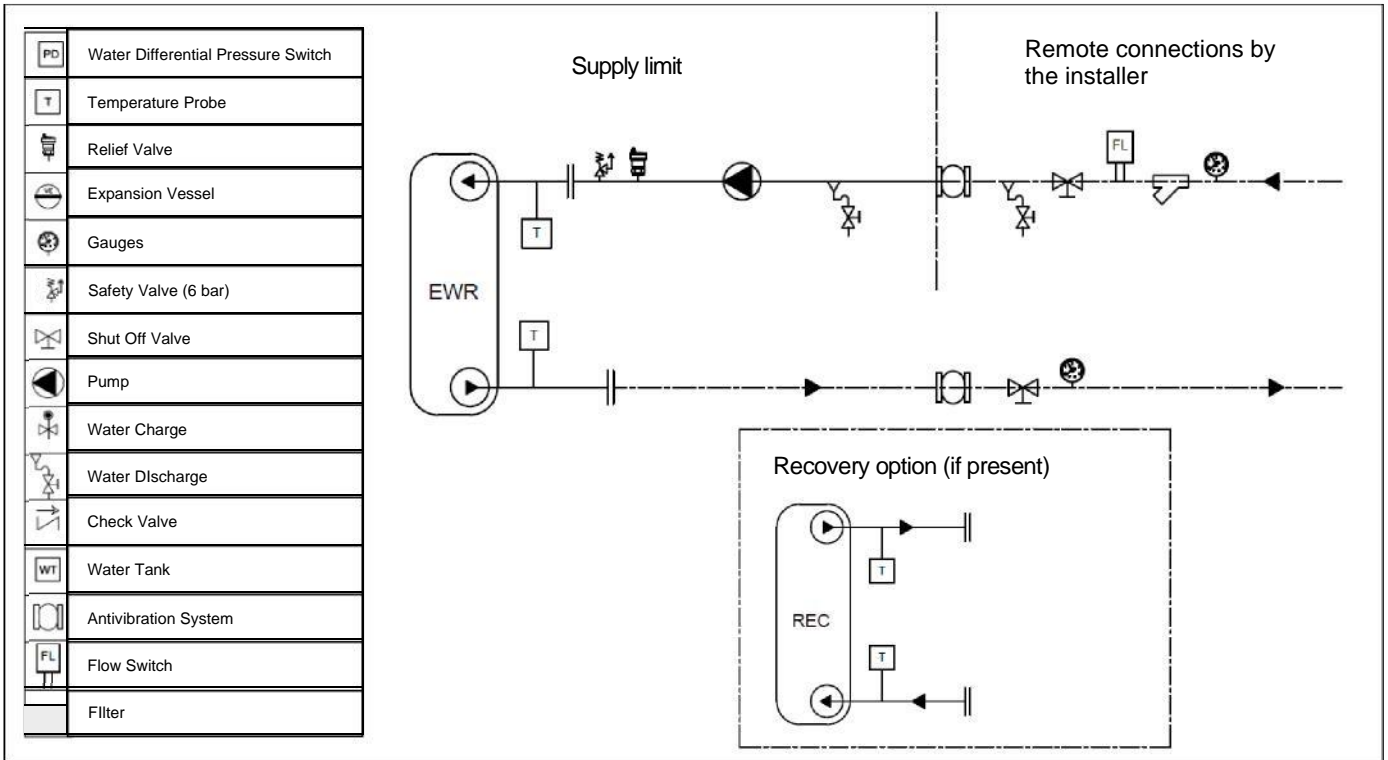

7.4.2 Hydraulic diagram for CCAXE units with single pump

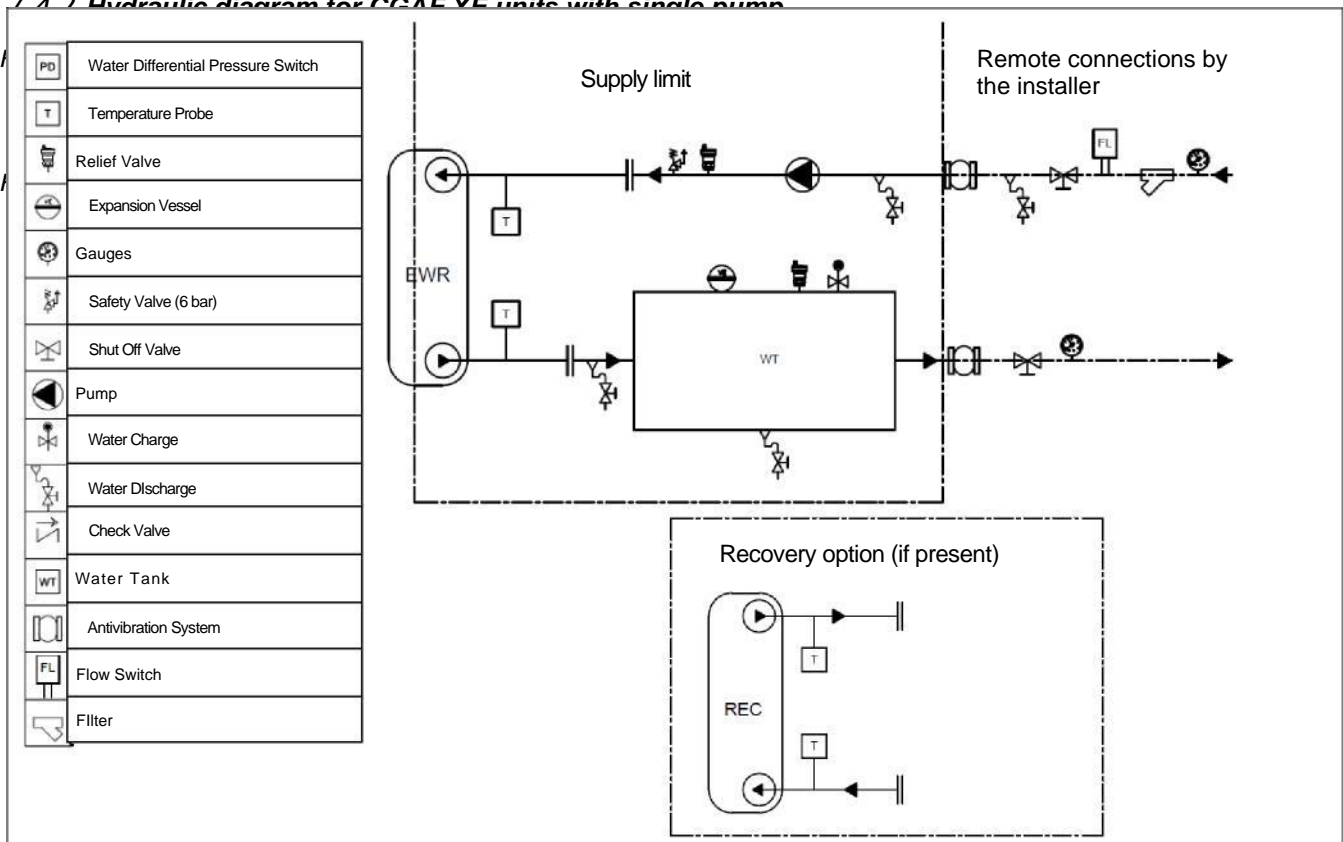

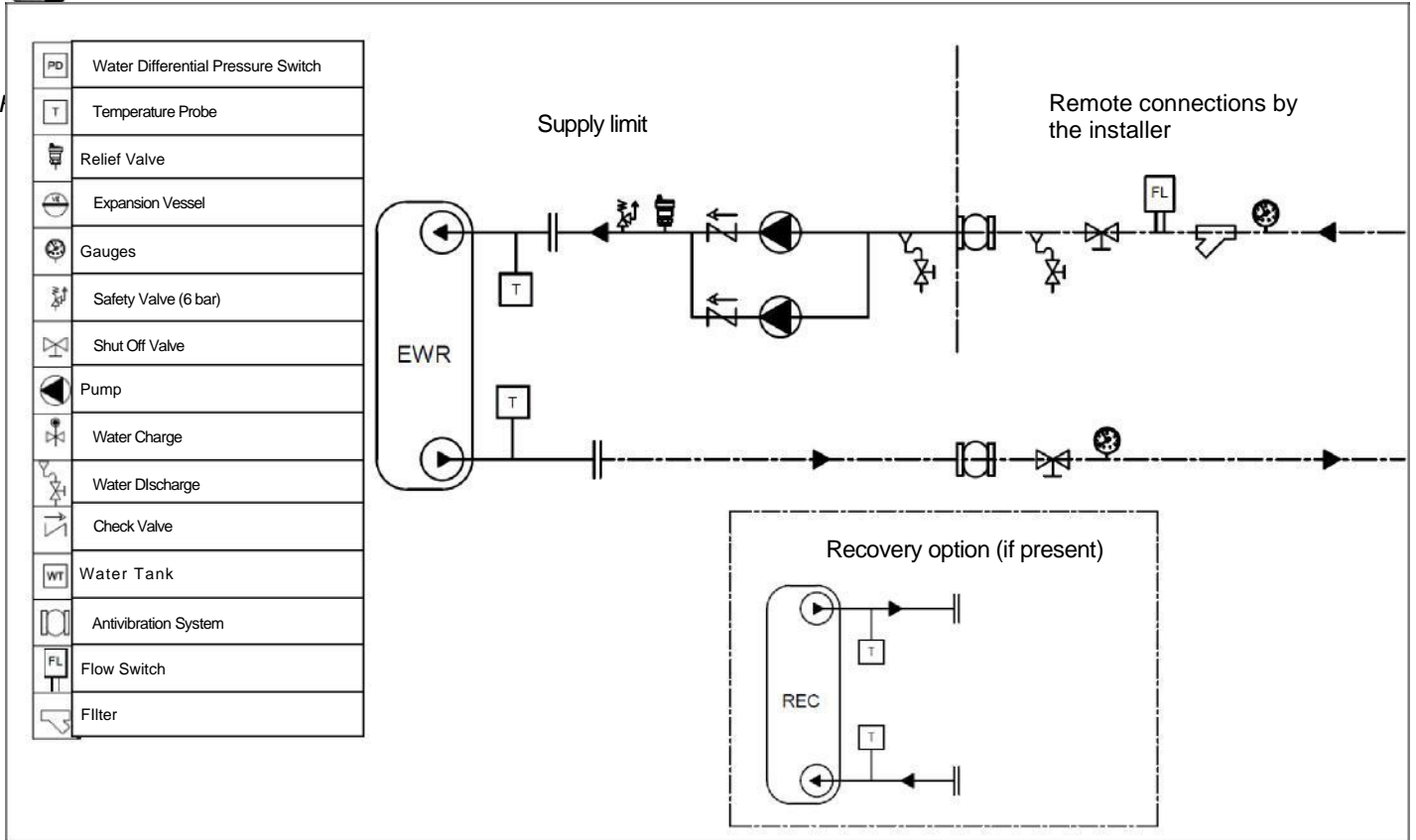

7.4.5 Hydraulic diagram for CGAF HE / CGAF XE units with single pump + stand-by pump and tank

Figure 6

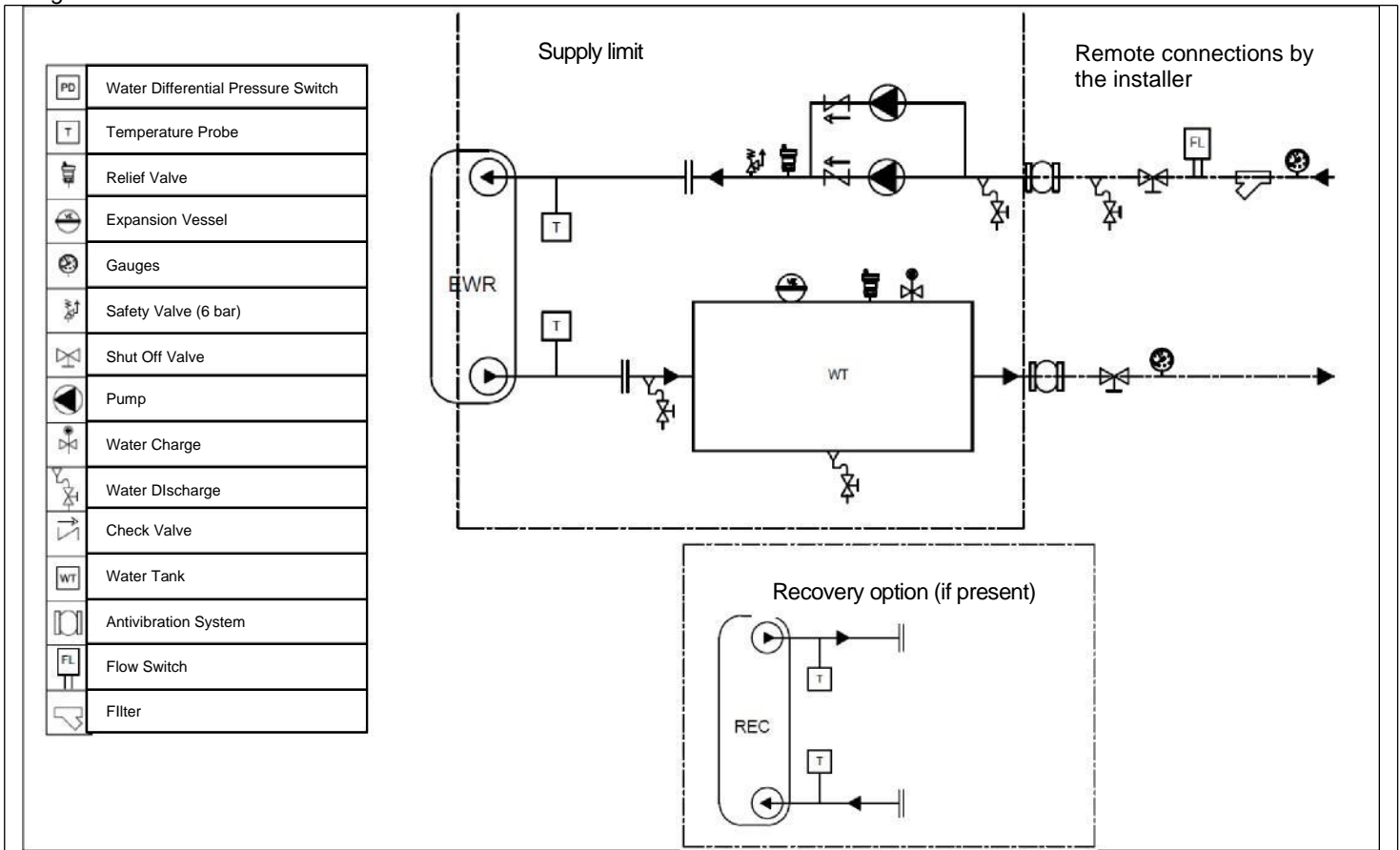

7.5 CUSTOMER PLANT SKETCHES

7.5.1 CGAF XE customer plant sketch with primary pump on evaporator side for unit with no on board

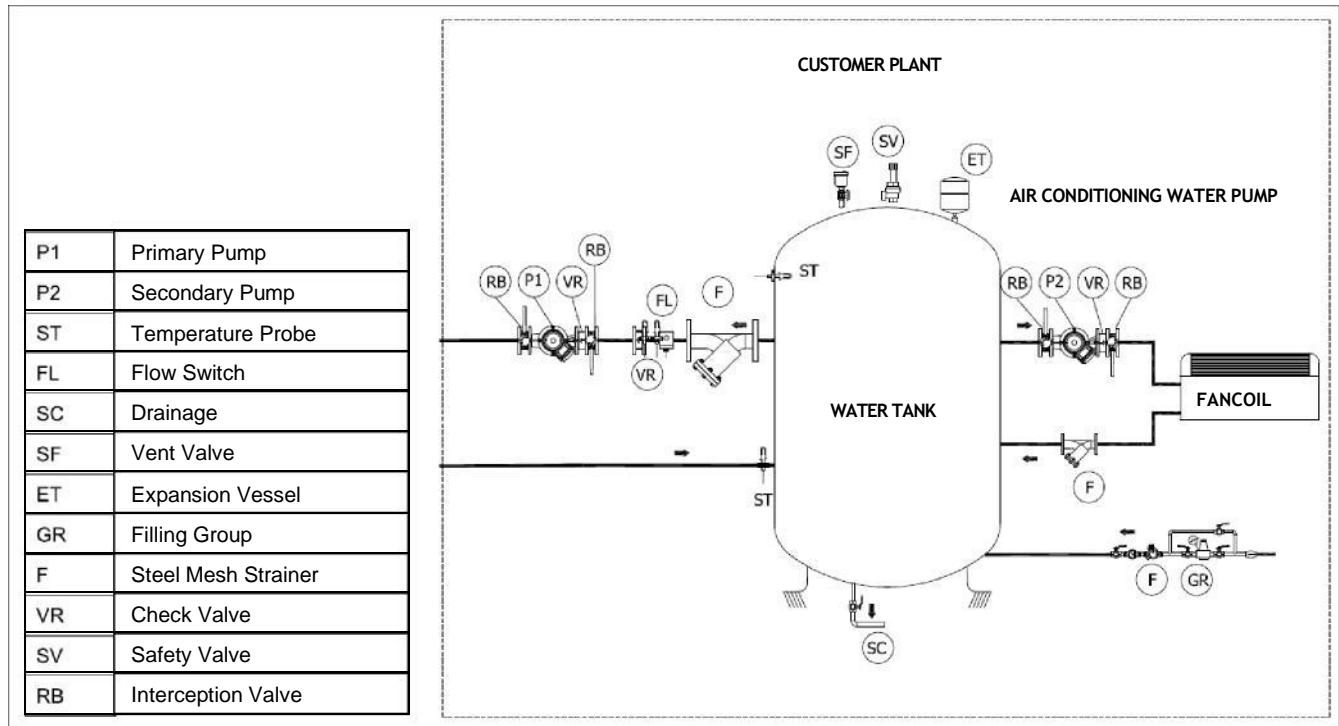

pump

Figure 7

IMPORTANT: the flow switch and the water strainer in the customer plant are obligatory to keep the warranty

7.5.2 CGAF XE customer plant sketch without primary pump on evaporator side for a unit with on board

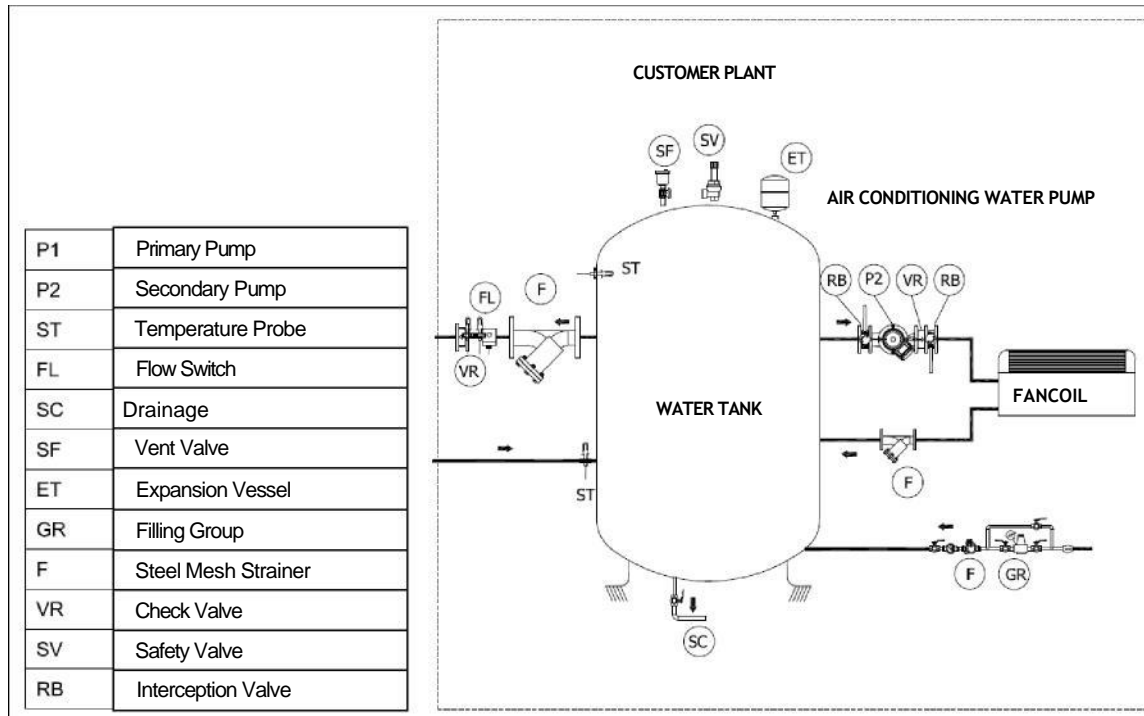

single pump or single pump + stand-by pump

Figure 8

IMPORTANT: the flow switch and the water strainer in the customer plant are obligatory in order to keep the warranty

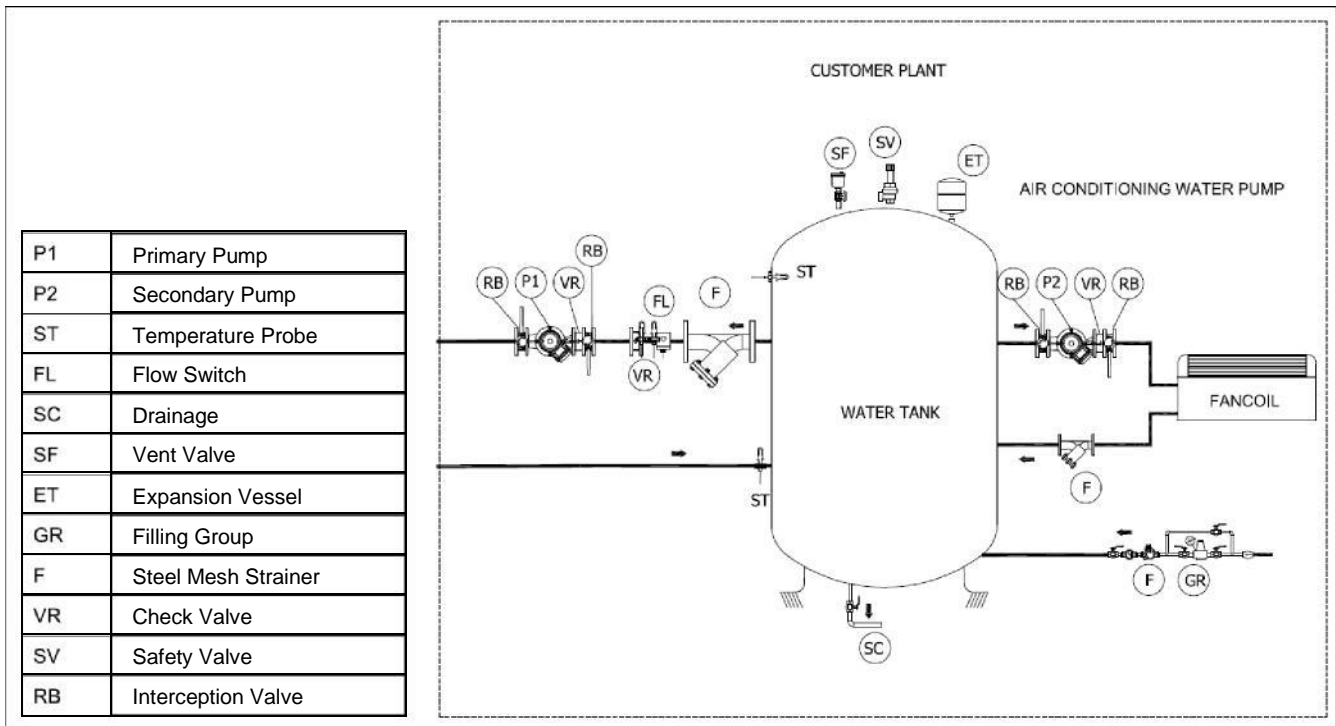

7.5.3 CGAF XE customer plant sketch on partial recovery exchanger (desuperheater) side

Figure 9

IMPORTANT: the flow switch and the water strainer in the customer plant are obligatory in order to keep the warranty

IMPORTANT: The desuperheater side pump is always installed in customer plant, an on board unit pump on desuperheater side is not possible not even as an option. The unit terminal board doesn't provide any signal for the control of this pump. This implies that the customer is supposed to activate and deactivate this pump by means of a temperature switch installed in the relevant water tank.



7.5.4 Flow switch installation

To ensure adequate water flow through the evaporator, it is essential to install a flow switch on the water circuit. The flow switch must be installed according to the relevant hydraulic diagram among those reported in the par 7.47.4 HYDRAULIC VERSIONS.

The purpose of the flow switch is to stop the unit in case of an interruption of the water flow while protecting the evaporator from freezing.

The flow switch installation can be horizontal and vertical, screw-in thread, RP 1" (ISO7/1). It should be installed far from elbows or throttling with an arrow on flow direction. If pipe is vertical recalibrate range to balance paddle weight. If the device is downwards mounted take care to slugs and apply it in a straight pipe far from filters, valves, etc **with length at least 5 times the diameter of pipe upstream and downstream the unit. The paddles must be installed starting from the shortest.**

Blade type flow switches are available as loose accessories and are suitable for harsh environments and for pipes with diameters from 1" to 8". The flow switch has a contact which must be wired, by the contractor, on the jobsite. Check the unit wiring diagram for more information. See the instruction sheet inside the flow switch box for information about positioning and settings.

Dimensions (mm)

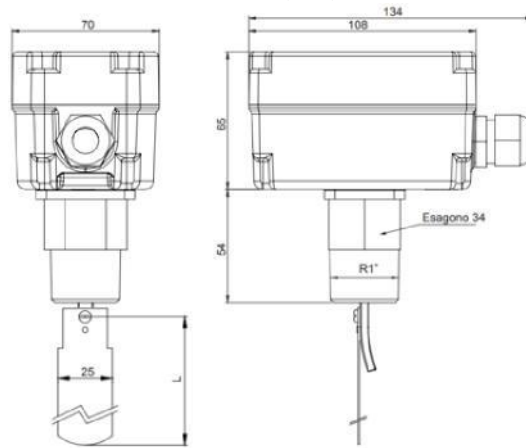

Figure 11

Paddle

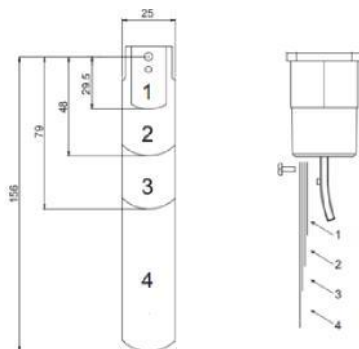

Figure 12

PIPES	TABLES
1"	1
1 1/4"	1
1 1/2"	1, 2
2"	1, 2
2 1/2"	1, 2, 3
3"	1, 2, 3
4"	1, 2, 3
5"	1, 2, 3
6"	1, 2, 3, 4
	1, 2, 3
8"	1, 2, 3, 4
	1, 2, 3

PUMPS CHARACTERISTICS

7.5.5 CGAF XE low head pressure pump characteristics for sizes 055 – 060 – 070 – 080 – 085 – 090 - 095 – 100

Mod.	q_w [m ³ /h]	dp_w [kPa]	Ref. Curve	Expansion Vessel [l]	F.L.I. [kW]	F.L.A. [A]	Hp [kPa]	Hu [kPa]
055	201	35	B	24	3,48	6,1	202	167
060	225	39	C	24	4,56	8,7	242	198
065	240	41	C	24	4,56	8,7	238	208
070	250	43	C	24	4,56	8,7	235	202
073	260	45	C	24	4,56	8,7	232	196
075	269	46	C	24	4,56	8,7	229	191

Pf = cooling capacity (kW)
qw = water flow (m³/h)
dpw = pressure drop (kPa)
F.L.I. = full load electrical power
F.L.A. = full load operating current
Hp = water pump head pressure
Hu = water pump available pressure

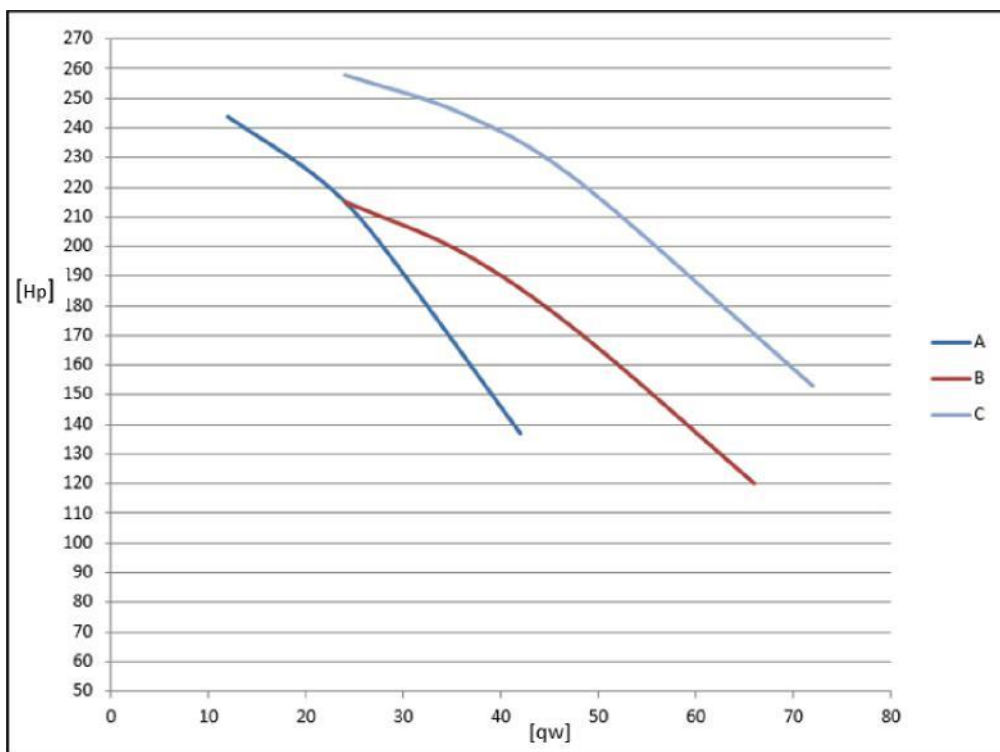



7.5.6 CGAF XE medium head pressure pump characteristics for sizes 055 – 060 – 070 – 080 – 085 – 090 - 095 – 100

Mod.	Pf	qw	dpw	Ref. Curve	Expansion vessel	F.L.I.	F.L.A.	Hp	Hu
[kW]		[m ³ /h]	[kPa]		[l]	[kW]	[A]	[kPa]	[kPa]
055	201	35	35	B	24	4,56	8,7	248	213
060	225	39	44	C	24	6,29	10,4	297	254
065	240	41	31	C	24	6,29	10,4	292	261
070	250	43	33	C	24	6,29	10,4	288	255
073	260	45	36	C	24	6,29	10,4	283	247
075	269	46	38	C	24	6,29	10,4	279	241

Pf = cooling capacity (kW)
 qw = water flow (m³/h)
 dpw = pressure drop (kPa)
 F.L.I. = full load electrical power
 F.L.A. = full load operating current
 Hp = water pump head pressure

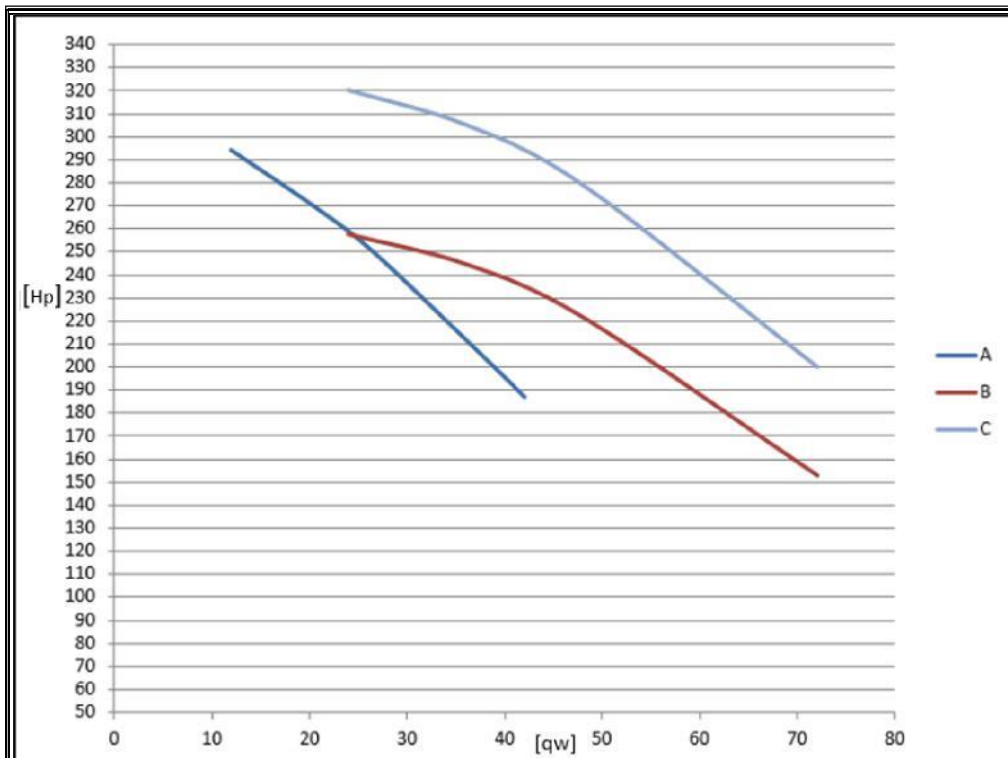

Hu = water pump available pressure

7.5.7 CGAF XE high head pressure pump characteristics for sizes 055 – 060 – 070 – 080 – 085 – 090 - 095 – 100

dpw Pf Mod. [kW]	qw [m ³ /h]	[kPa]	Ref. Curve	Expansion Vessel [l]	F.L.I. [kW]	F.L.A. [A]	Hp [kPa]	Hu [kPa]
055	201	35	B	24	6,29	10,4	306	270
060	225	39	C	24	8,26	13,6	297	254
065	240	41	C	24	8,26	13,6	360	329
070	250	43	C	24	8,26	13,6	356	323
073	260	45	C	24	8,26	13,6	352	317
075	269	46	C	24	8,26	13,6	349	311

Pf = cooling capacity (kW)
 qw = water flow (m³/h)
 dpw = pressure drop (kPa)
 F.L.I. = full load electrical

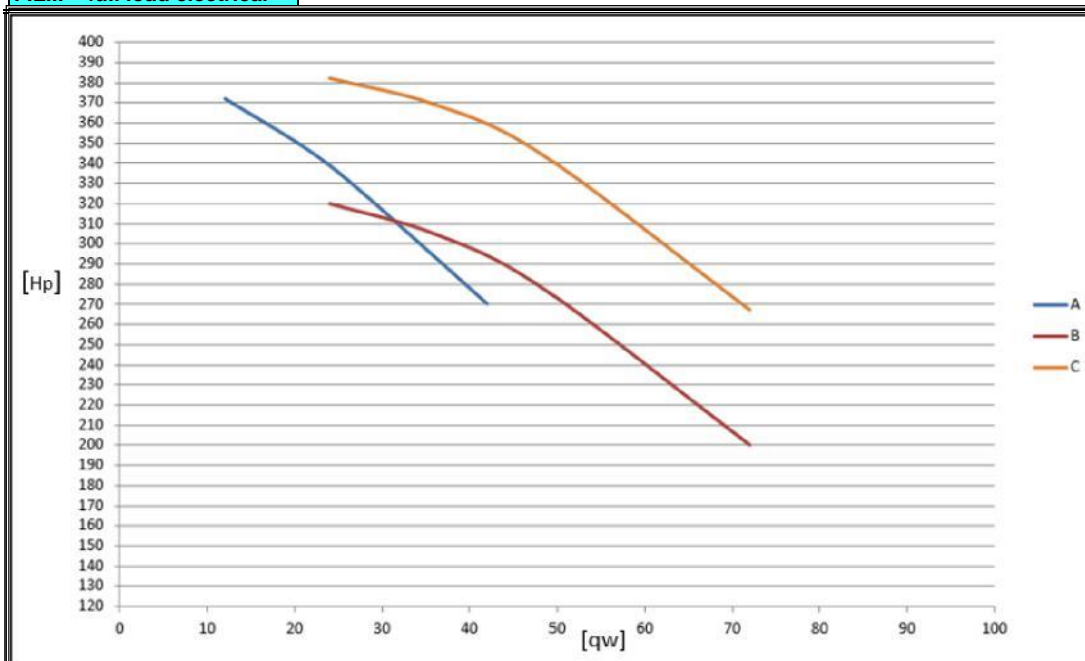

power
 F.L.A. = full load operating
 current
 Hp = water pump head
 pressure
 Hu = water pump available
 pressure



CGAF XE STANDARD REFRIGERANT SCHEMATIC

REFRIGERANT = R410a

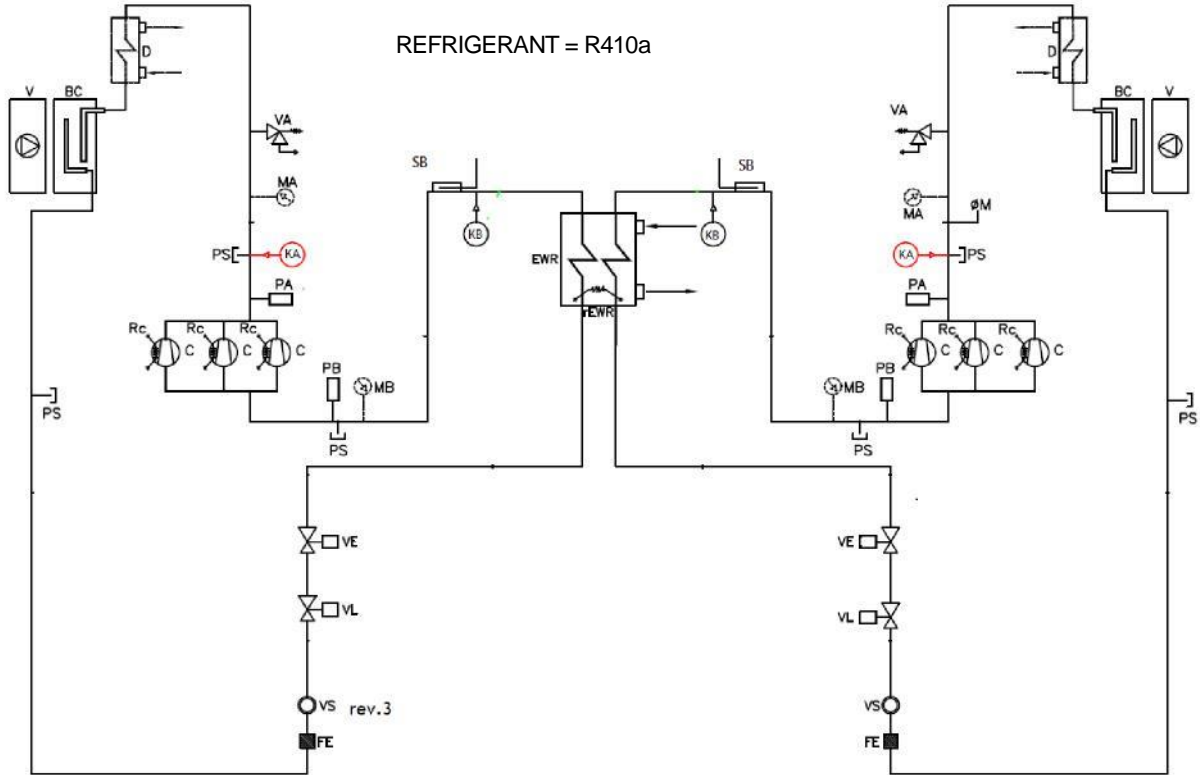

INDEX	
RC	CARTER HEATER
C	COMPRESSOR
PA	HP PRESSURE SWITCH
PS	SERVICE VALVE
MA	HP GAUGE
V A	SAFETY VALVE
BCE	CONDENSATION COIL
V	FAN
VNR	CHECK VALVE
PB	LP PRESSURE SWITCH
MB	LP GAUGE

INDEX	
VE	ELECTRONIC EXPANSION VALVE
VS	SIGHT GLASS
KA	HP TRANSDUCER
F	FILTER
EWR	EVAPORATOR
REWR	EVAPORATOR HEATER
VL	SOLENOID VALVE
KB	LP TRANSDUCER
D	DESUPERHEATER (IF PRESENT) FOR PARTIAL RECOVERY
SB	EXPANSION VALVE PROBE



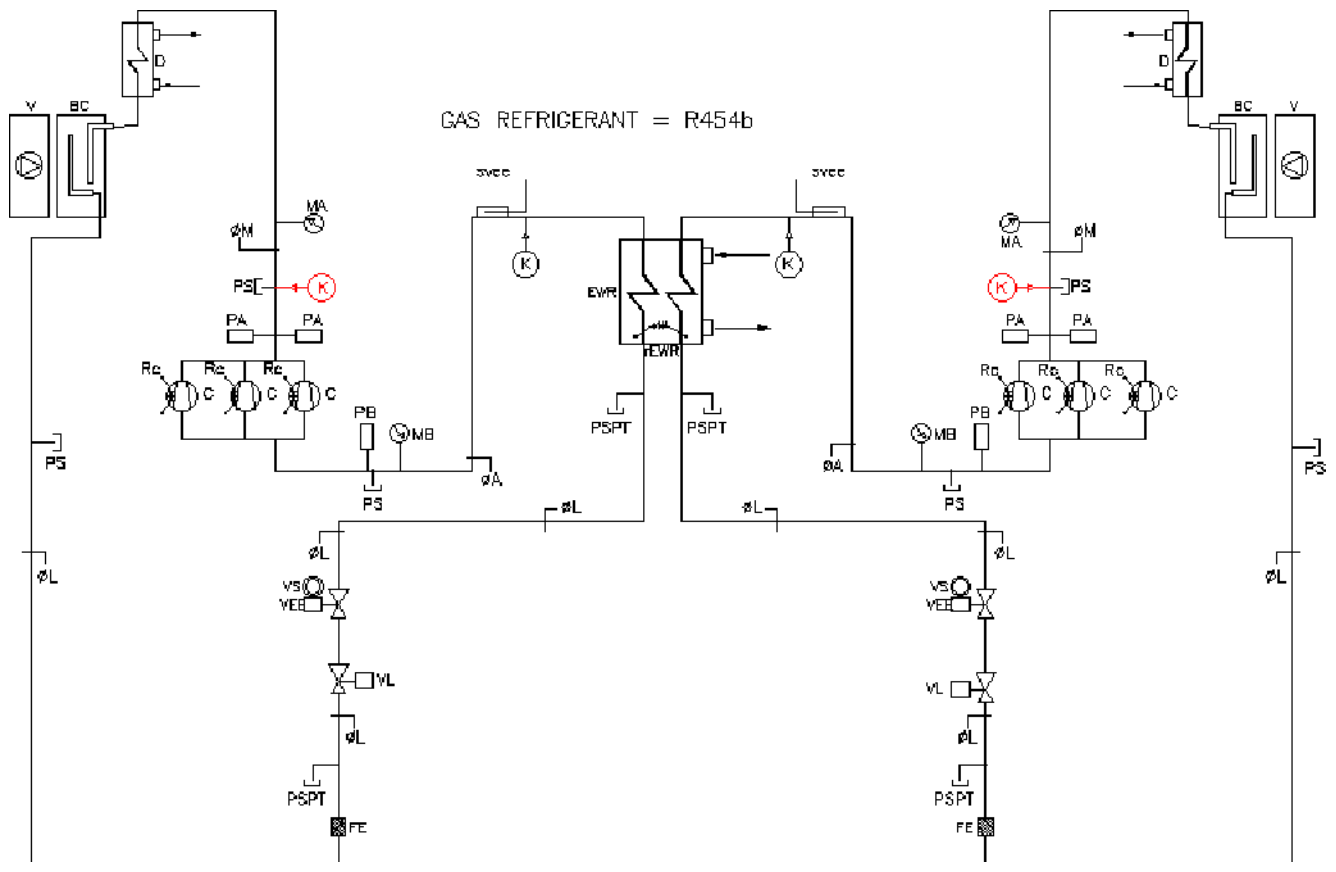

INDEX	
RC	CARTER HEATER
C	COMPRESSOR
PA	HP PRESSURE SWITCH
PS	SERVICE VALVE
MA	HP GAUGE
VA	SAFETY VALVE
BCE	CONDENSATION COIL
V	FAN
VNR	CHECK VALVE
PB	LP PRESSURE SWITCH
MB	LP GAUGE

INDEX	
VE	ELECTRONIC EXPANSION VALVE
VS	SIGHT GLASS
K	HP TRANSDUCER
FE	FILTER
EWR	EVAPORATOR
rEWR	EVAPORATOR HEATER
VL	SOLENOID VALVE
KB	LP TRANSDUCER
D	DESUPERHEATER (IF PRESENT) FOR PARTIAL RECOVERY
svee	EXPANSION VALVE PROBE
PSPT	FIRST SIZE SERVICE VALVE



9 ELECTRICAL PANEL AND ELECTRICAL DATA

When reviewing this manual keep in mind.

- All field-installed wiring must be in accordance with local regulations, CE directives and guidelines. Be sure to satisfy proper equipment grounding requirements according CE
- The standardized values - Maximum Amps –Maximum kWatts are displayed on unit nameplate.
- All field-installed wiring must be checked for proper terminations, and for possible shorts or grounds.

Ensure total protection against the possible penetration of water into the connection point.

All the cables and the terminals are univocally numbered according to the electrical scheme in order to avoid possible misinterpretation. The identification system of the cables connected to the components allow also an easy and intuitive recognition of the component. Each component of the electrical panel is provided with an identification plate according to what is shown on the electrical scheme. All the connections to the electrical panel are made from the bottom and are equipped with cover preventing from break. The electrical panel supply is 400V/3ph/50Hz so, no additional power supply is necessary. The entrance for the power cables is provided on the bottom of the box where a dismountable flange suitable for the purpose is provided.

The control circuit is powered with 24 VDC. Each unit is provided with auxiliary transformer control circuit 230/27VAC. It requires no additional power cable for the control equipment.

The unit has an antifreeze heater installed directly into the evaporator. The circuit also has an electric resistance installed in the compressor in order to keep warm the oil and thus avoid the transmigration of the refrigerant in its interior. Obviously, the operation of the electrical resistors is ensured as long as the unit is power supplied. The unit is equipped with an alarm relay, which changes state every time an alarm occurs in one of the cooling circuits. Connect the terminals as per the wiring diagram on the unit - terminal "X" - a visual or audible alarm or any external supervision system.

BMS to monitor its operation is allowed. See the wiring diagram of the unit for wiring.

WARNING To avoid corrosion, overheating or general damage, at terminal connections, unit is designed for copper conductors only. In case of aluminum conductors an intermediate connection box must be added. In case of aluminum cable bi material connecting device is mandatory. Cable routing inside control panel should be made case by case by installer.

WARNING Hazardous Voltage with Capacitor! Disconnect all electric power, including remote disconnects and discharge all motor start/run and capacitors before servicing. Follow proper lock out/tag out procedures to ensure the power cannot be inadvertently energized.

For variable frequency drives or other energy storing components provided by Trane or others, refer to the appropriate manufacturer's literature for allowable waiting periods for discharges capacitors. Verify with an appropriate voltmeter that all capacitors have discharged.

After disconnecting input power, wait five (5) minutes for units which are equipped with variable frequency drive (0V DC) before touching any internal components. Failure to follow these instructions could result in death or serious injury.

IMPORTANT if the unit is powered by a TT power supply system a differential protection should be suited for industrial machinery with current leak than can be higher than 500 mA (several motors and frequency drives)

VERY IMPORTANT due to the fact that the unit doesn't mount a refrigerant high pressure safety valve and therefore the safety device for a high pressure event is the high pressure switch, shunt trip coils are installed on compressors automatic circuit breakers in order to ensure the compressors stop in case a high pressure event should occur and in the same moment the electronic control shouldn't work properly. **This implies that if a high pressure event should occur a manual reset of the compressors automatic circuit breakers is needed.**

Electrical data R410A

NOMINAL VALUES								MAXIMUM VALUES				
condenser water temperature in/out 30/35°C, evaporator water temperature in/out 12/7°C												
Model CGAF HE R410A	Compressors			TOTAL				TOTAL				
	F.L.I.	F.L.A.	L.R.A.	F.L.I.	F.L.A.	S.A.	S.A. with soft starter	F.L.I.	F.L.A.	S.A.	L.R.A. with soft starter	S.A. with soft starter
	kW	A	A	kW	A	A	A	kW	A	A		A
055	59,8	104,7	215,0	65,2	115,4	304,2	196,7	87,2	147,3	323,5	118,2	237,5
060	71,1	124,4	215,0	76,4	135,0	318,9	211,4	99,9	166,2	342,5	129	256,5
065	75,7	132,4	260,0	81,0	143,0	369,9	239,9	104,8	174,0	387,5	129	283,5
070	80,2	140,4	260,0	85,5	151,0	375,9	245,9	109,6	181,8	395,3	156	291,3
073	85,0	148,7	260,0	90,3	159,3	382,2	252,2	114,5	189,7	403,1	156	299,1
075	89,7	157,0	260,0	95,0	167,7	388,4	258,4	119,4	190,3	410,9	156	306,9

Electrical data referred to 400V - 3Phases - 50Hz

Maximum operating admitted conditions: 10%

Maximum phase unbalance: 2%

F.L.I. = Full load electrical power

F.L.A. = Full load operating current

S.A. = Sum of compressor motor locked rotor current (**L.R.A.**) of most powerful compressor plus F.L.A of other compressor(s)

NOMINAL VALUES								MAXIMUM VALUES				
condenser water temperature in/out 30/35°C, evaporator water temperature in/out 12/7°C												
Model CGAF XE R410A	Compressors			TOTAL				TOTAL				
	F.L.I.	F.L.A.	L.R.A.	F.L.I.	F.L.A.	S.A.	S.A. with soft starter	F.L.I.	F.L.A.	S.A.	L.R.A. with soft starter	S.A. with soft starter
	kW	A	A	kW	A	A	A	kW	A	A		A
055	58,1	101,7	215,0	65,1	112,2	301,7	194,2	88,9	147,7	323,9	118,2	237,9
060	68,7	120,2	215,0	75,7	130,7	315,7	208,2	101,6	166,6	342,9	129	246,1
065	72,9	127,6	260,0	79,9	138,1	366,2	236,2	106,4	174,4	387,9	129	283,9
070	77,1	135,0	260,0	84,1	145,5	371,7	241,7	111,3	182,2	395,7	156	291,7
073	81,6	142,8	260,0	88,6	153,3	377,6	247,6	116,2	190,1	403,5	156	299,5
075	86,1	150,6	260,0	93,1	161,1	383,5	253,5	121,1	197,9	411,3	156	307,3

Electrical data referred to 400V - 3Phases - 50Hz

Maximum operating admitted conditions: 10%

Maximum phase unbalance: 2%

F.L.I. = Full load electrical power

F.L.A. = Full load operating current

S.A. = Sum of compressor motor locked rotor current (**L.R.A.**) of most powerful compressor plus F.L.A of other compressor(s)



Electrical data R454B

NOMINAL VALUES								MAXIMUM VALUES				
condenser water temperature in/out 30/35°C, evaporator water temperature in/out 12/7°C												
Model CGAF HE R454B	Compressors			TOTAL				TOTAL				
	F.L.I.	F.L.A.	L.R.A.	F.L.I.	F.L.A.	S.A.	S.A. with soft starter	F.L.I.	F.L.A.	S.A.	L.R.A. with soft starter	S.A. with soft starter
	kW	A	A	kW	A	A	A	kW	A	A		A
055	57,0	99,7	215,0	62,3	110,3	300,4	192,9	87,2	147,3	323,5	118,2	237,5
060	67,7	118,6	215,0	73,1	129,2	314,6	207,1	99,9	166,2	342,5	129	256,5
065	72,4	126,8	260,0	77,8	137,4	365,7	235,7	104,8	174,0	387,5	129	283,5
070	76,9	134,5	260,0	82,2	145,2	371,6	241,6	109,6	181,8	395,3	156	291,3
073	81,7	143,0	260,0	87,0	153,6	377,9	247,9	114,5	189,7	403,1	156	299,1
075	86,5	151,4	260,0	91,8	162,0	384,2	254,2	119,4	190,3	410,9	156	306,9

Electrical data referred to 400V - 3Phases - 50Hz

Maximum operating admitted conditions: 10%

Maximum phase unbalance: 2%

F.L.I. = Full load electrical power

F.L.A. = Full load operating current

S.A. = Sum of compressor motor locked rotor current (**L.R.A.**) of most powerful compressor plus F.L.A of other compressor(s)

NOMINAL VALUES								MAXIMUM VALUES				
condenser water temperature in/out 30/35°C, evaporator water temperature in/out 12/7°C												
Model CGAF XE R454B	Compressors			TOTAL				TOTAL				
	F.L.I.	F.L.A.	L.R.A.	F.L.I.	F.L.A.	S.A.	S.A. with soft starter	F.L.I.	F.L.A.	S.A.	L.R.A. with soft starter	S.A. with soft starter
	kW	A	A	kW	A	A	A	kW	A	A		A
055	55,0	96,3	215,0	62,0	106,8	297,7	190,2	88,9	147,7	323,9	118,2	237,9
060	65,1	114,0	215,0	72,1	124,5	311,0	203,5	101,6	166,6	342,9	129	246,1
065	69,4	121,4	260,0	76,4	131,9	361,6	231,6	106,4	174,4	387,9	129	283,9
070	73,6	128,9	260,0	80,6	139,4	367,1	237,1	111,3	182,2	395,7	156	291,7
073	78,1	136,7	260,0	85,1	147,2	373,0	243,0	116,2	190,1	403,5	156	299,5
075	82,5	144,4	260,0	89,5	154,9	378,8	248,8	121,1	197,9	411,3	156	307,3

Electrical data referred to 400V - 3Phases - 50Hz

Maximum operating admitted conditions: 10%

Maximum phase unbalance: 2%

F.L.I. = Full load electrical power

F.L.A. = Full load operating current

S.A. = Sum of compressor motor locked rotor current (**L.R.A.**) of most powerful compressor plus F.L.A of other compressor(s)

10 OPERATOR RESPONSABILITIES

It is important that the operator is properly trained and familiar with the equipment before working on the unit. In addition to reading this manual, the operator must study the manual operation of the microprocessor and the wiring diagram to understand the sequence of start-up, operation, shutdown sequences, and the criterion of operation of all safety devices. During the initial start-up of the unit an authorized technician is available to answer any questions and educate on the proper functioning. We recommend the operator to maintain a record of the operating data for each unit installed and all maintenance activities and periodic service. If the operator observes abnormal or unusual operating conditions, consult the authorized service technician.

11 START-UP PRELIMINARY PROCEDURES

11.1 STARTING CHECK

Before starting the unit, even only momentarily, all the machinery supplied by the chilled water, like the air handling units, pumps, etc. have to be checked. The pump auxiliary contacts and the flow switch have to be connected to the control panel as indicated in the electrical diagram. Before carrying out interventions on the valve regulations, loosen the relevant valve gland. Open the discharge valve of the compressor. Open the liquid shutoff valve placed on the liquid line. Measure the suction pressure. If it is lower than 0.42 MPa jumper and strain the solenoid valve on the liquid line. Bring the suction pressure to 0.45 MPa, then remove the jumper. Charge all the water circuit progressively. Starts up the water pump of the evaporator with the calibration valve shut and then slowly open it.

Discharge the air from the high points of the water circuit and check the direction of the water flow. Carry out calibration of the flow by using a measurer (if present or available) or by means of a combination of the readings of the manometers and the thermometers. In the starting phase calibrate the valve on the pressure difference read on the manometers, carry out drainage of the tubes and then carry out fine calibration on the temperature difference between the water in and the water out. The regulation is calibrated in the factory for water in to the evaporator at 12°C and water out at 7°C. With the general switch open, check that the electrical connections are tightly clamped. Check for any possible refrigerant leaks. Check that the electrical data on the label correspond to those of the mains supply. Check that the thermal charge available is appropriate for starting.

11.2 REFRIGERANT SEALS CONTROL

Trane units are sent with the complete charge of refrigerant and are at a sufficient pressure to check the seal after installing. If the system were not under pressure, blow refrigerants (vapour) into it until pressure is reached and look for leakage.

After having eliminated the leakage, the system has to be dehydrated with a vacuum pump up to at least 1mm Hg - absolute pressure (1 Torr o 133.3 Pa). This is the minimum recommended value to dehydrate the plant.

Danger Do not use the compressor to vacuum the system.

11.3 REFRIGERANT CHARGE CHECK

Trane units are supplied with a complete charge of refrigerant. If bubbles can be seen through the peephole with the compressor running with a full charge and steadily, it means that the refrigerant charge is insufficient



DATE		N.	
UNIT			

13 CHECK LIST - MANDATORY OPERATION CONTROL BEFORE START-UP

CUSTOMER:	SITE:
	ADDRESS:
	POSTCODE:
	COUNTRY:

THE INTENDED PURPOSE OF CGAF HE / CGAF XE UNITS IS NOT FOR INDUSTRIAL PROCESS APPLICATION. PLEASE CONTACT TRANE TECHNICAL DEPARTMENT IN CASE OF INDUSTRIAL PROCESS APPLICATION.

GENERAL

		COMPLIANCE	
		YES	NO
1	THE HYDRAULIC CIRCUIT IS COMPLETE AND READY TO BE USED AND THE THERMAL LOAD IS AVAILABLE. PLEASE NOTE THAT THE FIRST START-UP SHALL NOT BE CARRIED OUT UNLESS THE PLANT IS READY AND THE WATER LOAD IS AVAILABLE.		
2	THE UNIT DISPLAYS DENTS OR DAMAGES ON THE EXTERNAL CASING OCCURRED DURING THE TRANSPORTATION OR POSITIONING. IF ANY, SPECIFY BELOW: WARNING: PLEASE BE AWARE THAT RELEVANT DAMAGES CAUSED BY THE QUOTED CIRCUMSTANCES MAY RESULT IN THE CALL-OFF OF THE WARRANTY.		
3	THE UNIT HAS BEEN INSTALLED IN ACCORDANCE WITH THE MINIMUM DISTANCE PROVIDED IN THE DIMENSIONAL DRAWING AND TECHNICAL DOCUMENTATION PROVIDED.		
4	THE UNIT IS INSTALLED NEXT TO THE: PHOTOVOLTAIC SYSTEM, ELECTRONIC TRANSMITTERS, ANTENNAS OR SIMILAR DEVICES.		
5	THE UNIT IS POSITIONED ON A PERFECTLY FLAT (NOT INCLINED) SURFACE.		
6	ANTI-VIBRATIONS DAMPERS HAVE BEEN INSTALLED BETWEEN THE UNIT AND THE FLOOR.		
7	THE UNIT DISPLAYS DEFECTS OR DAMAGES RESULTING FROM MODIFICATIONS OR CHANGES (UNIT TAMPERING / UNAUTHORIZED MODIFICATIONS TO THE REFRIGERANT CIRCUIT OR THE HYDRAULIC CIRCUIT OR THE ELECTRICAL PANEL OR CHANGES TO THE UNIT OPERATING PARAMETERS) MADE BY A THIRD PERSON WITHOUT A WRITTEN AUTHORIZATION ISSUED BY TRANE. THE UNIT SHALL BE CONFORM TO TRANE WIRING DIAGRAMS AND TECHNICAL DOCUMENTATION) IN CASE OF RELEVANT DIFFERENCE BETWEEN THE UNIT AND TRANE STANDARD CONFIGURATION PLEASE CONTACT TRANE. WARNING: PLEASE BE AWARE THAT RELEVANT DAMAGES CAUSED BY THE QUOTED CIRCUMSTANCES MAY RESULT IN THE CALL-OFF OF THE WARRANTY.		
8	THE UNIT HAS BEEN INSTALLED VERY CLOSE TO A MARINE ENVIRONMENT OR AN AGGRESSIVE INSTALLATION ENVIRONMENT (HIGHLY CORROSIVE CHEMICAL AGENT). WARNING: PLEASE BE AWARE THAT RELEVANT DAMAGES CAUSED BY THE QUOTED CIRCUMSTANCES MAY RESULT IN THE CALL-OFF OF THE WARRANTY.		
9	SPOTTED PRESENCE OF MOLD, MUSHROOMS, BACTERIA, MICROBIAL OF ANY TYPE.		
10	THE UNIT DISPLAYS DAMAGES CAUSED BY: FLOODS, LIGHTNING, FIRE, ANY ACCIDENT BEYOND TRANE CONTROL.		

ELECTRIC AND ELECTRONIC

	COMPLIANCE	
	YES	NO
11 THE UNIT IS ELECTRICALLY POWERED AND ALL THE RELEVANT ELECTRICAL WIRES ARE PROPERLY CONNECTED.		
12 ELECTRICAL SUPPLY HAS BEEN INSTALLED IN ACCORDANCE WITH THE INSTRUCTIONS PROVIDED IN THE NAME PLATE AND IN THE TECHNICAL DOCUMENTATION. (ELECTRICAL POWER SUPPLY: 230V/400V +/- 10% - MAXIMUM "% OF PHASE IMBALANCE: +/- 2%). IT IS RECOMMENDABLE TO CHECK BY USING A TESTER THE VOLTAGE VALUE (BETWEEN PHASES AND BETWEEN PHASE AND NEUTRAL)		
13 PHASES ARE CONNECTED IN THE PROPER SEQUENCE.		
14 ELECTRICAL CABLES SIZE ARE CONFORM TO FLA MAX VALUE.		
15 BOTH EXTERNAL AND INTERNAL ELECTRICAL WIRES ARE WELL TIGHTENED.		
16 THE COMPRESSOR CRANCKCASE HEATERS HAVE BEEN POWERED AND HEATED AT LEAST 8 HOURS BEFORE THE START-UP		
17 AN ELECTRONIC SUPERVISOR (OR ANY ADDITIONAL CONTROLLER) HAS BEEN INSTALLED.		
18 THE CONNECTION WIRES ARE SHIELDED.		
19 REMOTE CONTROL DEVICES OR INTERFACES ARE CONNECTED TO THE ELECTRICAL PANEL IN CONFORMITY WITH TRANE WIRING DIAGRAMS		
20 ELECTRONIC DEVICES ARE INTACT AND DON'T DISPLAY ANY DAMAGE.		
21 AN EXTERNAL WATER PUMP IS ELECTRICALLY CONNECTED TO THE ELECTRICAL PANEL IN ACCORDANCE WITH THE WIRING DIAGRAMS PROVIDED BY TRANE		
22 THE ELECTRICAL ABSORPTION AND THE WATER PUMP OVERHEATING ARE STANDARD.		

REFRIGERANT CIRCUIT

	COMPLIANCE	
	YES	NO
23 ALL CONNECTIONS ON THE REFRIGERANT CIRCUITS ARE WELL TIGHTENED.		
24 THE ELECTRONIC LEAKAGE DETECTOR OR THE PRESSURE GAUGE LEVEL INSTALLED ON THE REFRIGERANT CIRCUIT HAVE DETECTED ANY LEAKAGE. IF ANY, SPECIFY BELOW:		
25 THE COMPRESSOR OIL INDICATOR LIGHT POINTS THE MAXIMUM LEVEL.		
26 THE FILTER INDICATOR LIGHT ON THE LIQUID LINE IS GREEN. WARNING: THE YELLOW INDICATOR LIGHT INDICATES PRESENCE OF MOISTURE IN THE CIRCUIT. IN THIS CASE PLEASE CONTACT TRANE.		



WATER CIRCUIT

		COMPLIANCE	
		YES	NO
27	<p>THE FILTER IS INSTALLED ON THE HEAT EXCHANGER INLET PIPES, AT A MAXIMUM DISTANCE OF 2 METERS FROM THE UNIT.</p> <p>PLEASE NOTE THAT THE FILTER INSTALLATION IS MANDATORY. FOR FURTHER TECHNICAL INFORMATION RELATING THE FILTER PLEASE REFER TO THE TECHNICAL DOCUMENTATIONS.</p>		
28	<p>THE FLOW SWITCH HAS BEEN INSTALLED AND ELECTRICALLY CONNECTED. PLEASE NOTE THAT FLOW SWITCH INSTALLATION IS MANDATORY.</p>		
29	<p>THE VALVES ON THE WATER PLANT MUST BE OPENED. PLEASE BE AWARE THAT IF THE MACHINE IS POWERED (OR IN STAND-BY MODE) PUMPS WILL START IF THE WATER TEMPERATURE IS EQUAL OR BELOW 4°C. CLOSING THE VALVES MAY THEREFORE CAUSE SEVERE DAMAGES.</p>		
30	<p>DRAINAGE VALVES ARE INSTALLED. THE DRAINAGE VALVES ARE INSTALLED ON THE LOWEST POINT. THE UTILIZATION OF AUTOMATIC DRAINAGE VALVES IS RECOMMENDED.</p>		
31	<p>AUTOMATIC OR MANUAL PURGE VALVES ARE INSTALLED.</p> <p>AUTOMATIC OR MANUAL PURGE VALVES ARE INSTALLED ON THE HIGHEST POINT.</p>		
32	<p>THE HYDRAULIC CIRCUIT HAS BEEN FILLED AND PURGED.</p> <p>THE PLANT SHALL BE PURGED SEVERAL TIMES BEFORE STARTING UP THE UNIT. THE FILTER INSTALLED NEXT TO THE HEAT EXCHANGER SHALL BE CLEANED SEVERAL TIMES BEFORE STARTING UP THE UNIT, UNTIL THE CORRECT DELTA T IS ASSURED AND THE HYDRAULIC PRESSURE IS CONFORM TO THE PLANT AND TO THE WATER PRESSURE DROPS. FOR FURTHER TECHICAL INFORMATIONS PLEASE REFER TO TRANE DOCUMENTATIONS AND PROCEDURE FOR THE FIRST START UP.</p>		
33	<p>HYDRAULIC CONNECTIONS TO THE UNIT ARE COMPLIANT WITH THE UNIT NAME PLATE AND DIMENSIONAL DRAWINGS (HOT WATER INLET, HOT WATER OUTLET, COLD WATER INLET, COLD WATER OUTLET, ETC.).</p>		
34	<p>RUBBER JOINTS ARE INSTALLED ON THE HYDRAULIC CONNECTIONS, IN ORDER TO MINIMIZE VIBRATIONS BETWEEN THE UNIT AND WATER PIPES.</p>		
35	<p>SHUTOFF VALVES ARE INSTALLED ON THE HYDRAULIC CIRCUIT.</p>		
36	<p>THE EXPANSION TANK IS INSTALLED ON THE HYDRAULIC CIRCUIT. EXPANSION TANK CAPACITY CONCURS WITH THE WATER PLANT CAPACITY.</p>		
37	<p>TEMPERATURE PROBES AND PRESSURE GAUGES ARE INSTALLED ON THE HYDRAULIC CIRCUIT, BOTH INLET AND OUTLET SIDE.</p>		
38	<p>THE HYDRAULIC CIRCUIT IS FREE FROM OBSTRUCTION OR ANY KIND OF CONSTRAINT.</p>		
39	<p>BUFFER TANKS ARE INSTALLED IN THE HYDRAULIC CIRCUIT. THE BUFFER TANKS INSTALLATION IS STRONGLY RECOMMENDED IN ORDER TO WARRANTY THE OPTIMAL UNIT OPERATION.</p> <p>SPECIFY BUFFER TANK CAPACITY:LT</p>		
40	<p>THE PRESSURE RELIEF VALVE IS INSTALLED BETWEEN DELIVERY AND RETURN PIPES.</p> <p>WARNING: IN ORDER TO AVOID WATER-HAMMER, THE RELIEF VALVE PRESSURE SHALL BE SET UP IN ACCORDANCE WITH THE STANDARD OPERATING PRESSURE OF THE WATER CIRCUIT.</p>		
41	<p>THE AUXILIARY HEATING SYSTEM IS INSTALLED IN THE WATER CIRCUIT IN ORDER TO AVOID THE START-UP OF THE UNIT WITH WATER TEMPERATURE BELOW 18°C. BEFORE STARTING UP THE UNIT THE INLET WATER TEMPERATURE MUST BE EQUAL OR HIGHER THAN 18°C.</p> <p>WARNING: THE UNIT SHALL NEVER WORK (NOT EVEN FOR SHORT PERIODS) WITH AN INLET WATER TEMPERATURE LOWER THAN 18°C.</p>		



<p>ANTIFREEZE PROTECTIONS ARE INSTALLED IN THE WATER CIRCUIT (ELECTRICAL HEATERS ARE INSTALLED ON WATER PIPES AND TANKS).</p> <p>42 FOR FURTHER TECHNICAL INFORMATION PLEASE REFER TO TECHNICAL DOCUMENTATION PROVIDED. PLEASE NOTE THAT ANTIFREEZE PROTECTIONS ARE MANDATORY FOR OUTDOOR AIR TEMPERATURE LOWER THAN 3°C.</p>		
<p>43 THE WATER CIRCUIT IS FILLED WITH ETHYLENE GLYCOL. ETHYLENE GLYCOL “%” SHALL CONFORM WITH THE DATA PROVIDED IN THE TECHNICAL DOCUMENTATION.</p>		
<p>44 ALL WATER PIPES ARE GROUND CONNECTED (IN ORDER TO AVOID ABNORMAL VOLTAGES THAT CAN CAUSE DANGEROUS CORROSIONS).</p>		
<p>45 THE EVAPORATOR WATER FLOW IS COMPLIANT TO THE TECHNICAL DOCUMENTATION PROVIDED BY TRANE.</p>		
<p>46 THE WATER PUMPS ARE CORRECTLY SET UP IN ACCORDANCE WITH THE PLANT WATER FLOW, AVAILABLE HEAD PRESSURE AND PRESSURE DROP.</p>		
<p>47 THE PUMP IMPELLERS ARE MECHANICALLY UNBLOCKED AND UNCLOGGED (FREE FROM ANY KIND OF CONSTRAINTS.)</p>		

<p>DATE:</p>	<p>AUTHORIZED SERVICE:</p>	<p>CUSTOMER:</p>
	<p>NAME AND SIGNATURE</p>	<p>NAME AND SIGNATURE</p>

13.1 REFRIGERANT CHARGE

13.1.1 Refrigerant replacement procedure with unit stopped and in vacuum (refrigerant charge in the liquid phase)

Open the shut off valve as far as possible so that it closes the service coupling. Connect the refrigerant cylinder to the service coupling without tightening the coupling. Half close the liquid shut off valve. If the circuit has been dehydrated and is in vacuum, charge the liquid by turning the cylinder upside down. Weigh and charge the appropriate quantity. Open the valve completely. Start up the unit and leave it running at full charge for some minutes. Check that the indicator is clear with no bubbles. Make sure that the transparency condition without bubbles is due to the liquid and not to the vapour. Correct functioning of the unit allows for overheating of 4 - 7° C and sub cooling of 4 - 8°C. Values of overheating which are too high may be caused by a lack of refrigerant, whereas high sub cooling values may mean an excess of charge. After intervention on the charge, it is appropriate to check that the unit runs within the declared values: with unit steadily running on a full charge, measure the temperature of the suction line downstream of the thermostatic valve bulb; read the balance pressure to the evaporator on the low pressure manometer and the corresponding saturation temperature.

Overheating is equal to the difference between the temperatures measured in this way. Then measure the temperature of the liquid line coming out of the condenser and read the balance pressure to the condenser on the high -pressure manometer and the corresponding saturation temperature. The sub cooling is the difference between these temperatures.

Danger While refrigerant is being added do not exclude any control system and let the water circulate in the evaporator to avoid the formation of ice.

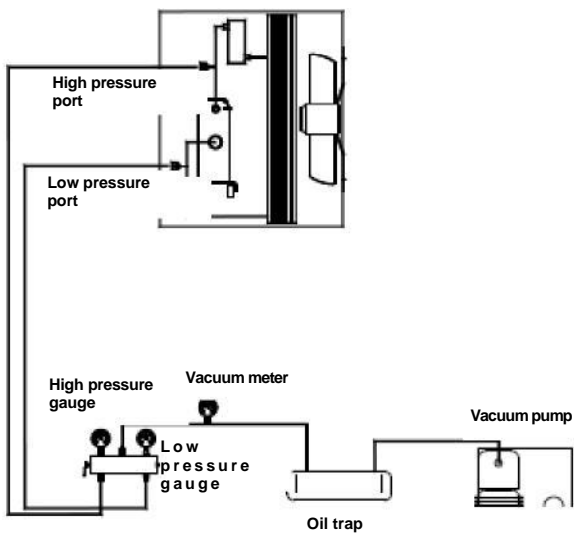

Refrigerant circuit diagram connection to vacuum pump

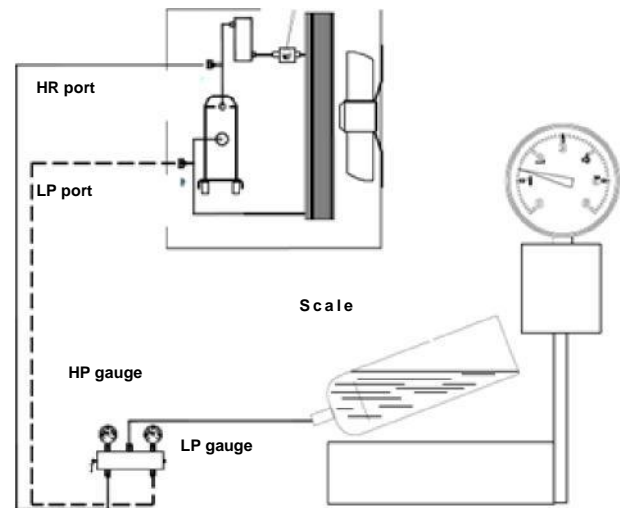

Refrigerant charge in the liquid phase

13.1.2 Refrigerant replacement procedure with unit running (refrigerant charge in the vapour phase)

Caution: charge vapour only. Do not charge liquid because it may damage the compressor.

Connect the refrigerant cylinder to the service valve without tightening the coupling. Drain the connection piping and tighten the coupling. Charge the circuit until the indicator indicates liquid without bubbles. Now the unit has the required charge. Make sure not to over charge the circuit. Charging more than necessary leads to a higher delivery pressure, greater power consumption and possible damage to the compressor.

The symptoms of a low refrigerant charge are:

Low evaporation pressure.

High value of superheating.

Low value of sub cooling.

In this case, add refrigerant R410A or R454B. The system is provided with a charging port between the expansion valve and the evaporator. Charge refrigerant until conditions return to work normal. Remember to replace the cap closing the valve at the end.

IMPORTANT!

If the unit has not been provided with integrated pump on board, do not turn off the external pump before 3 minutes have elapsed after turning off the last compressor. The early shutdown of the pump causes a water flow alarm failure.

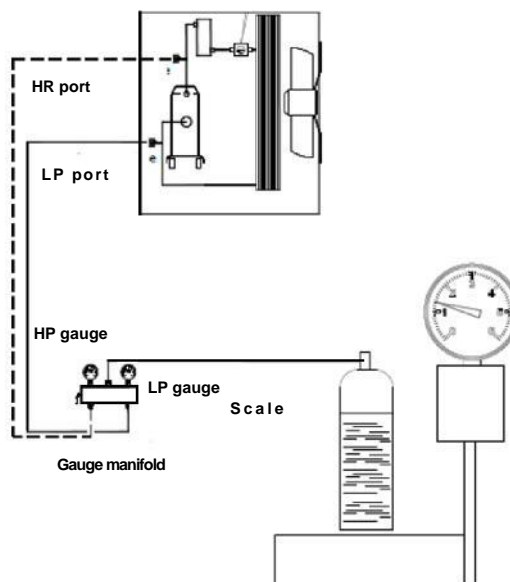

Liquid sight glass

Refrigerant charge in the vapour phase

14 START-UP

14.1 PRELIMINARY CONTROLS

Before starting up the equipment it is very important to check that all the operations described in the paragraph "CHECK LIST – MANDATORY OPERATION CONTROL BEFORE START UP" have been carried out correctly.

Moreover check that all the mechanical and electric equipment has been tightened perfectly. Particular attention should be paid to the main components (compressor, exchangers, ventilators, electrical motors, and pump) if loose fastenings are found, tighten them well before starting up the machine.

The oil heaters have to be inserted at least 8 hours before starting up. Ensure that the compressors' carter is hot. Open the compressor valve and the cooling circuit one, which may have been shut for charging. Control all the machinery connected to the unit.

14.2 STARTING UP

All the compressors mounted on Trane units are factory charged with oil whose chemical characteristic of stability are very good, so it is not necessary to change frequently the lubricant oil.

The scroll compressors are equipped with an oil sight glass from which you can control the level. In tandem or trio performances, pay particular attention to oil level. Not perfectly leveled sight glasses between compressors in parallel, but falling in the upper and lower limits, are considered normal.

Next to the lamp there is a connection on every compressor for draining the oil and a connection for refilling.

To refill oil, there is a 1/4" Schrader connection.

To refill oil, it is necessary to discharge the refrigerant in the unit, recovering it in adequate cylinders. Then vacuum until you reach a pressure of about 6 Pa to remove any trace of humidity from the circuit. Then load the unit with a small amount of refrigerant and fill oil from the proper connection for refilling.

Add oil until the oil sight glass is flat within the upper and lower limits indicated by the corresponding notches.

At this point refill the previously discharged amount of refrigerant as in the indications above. Restart the compressor.

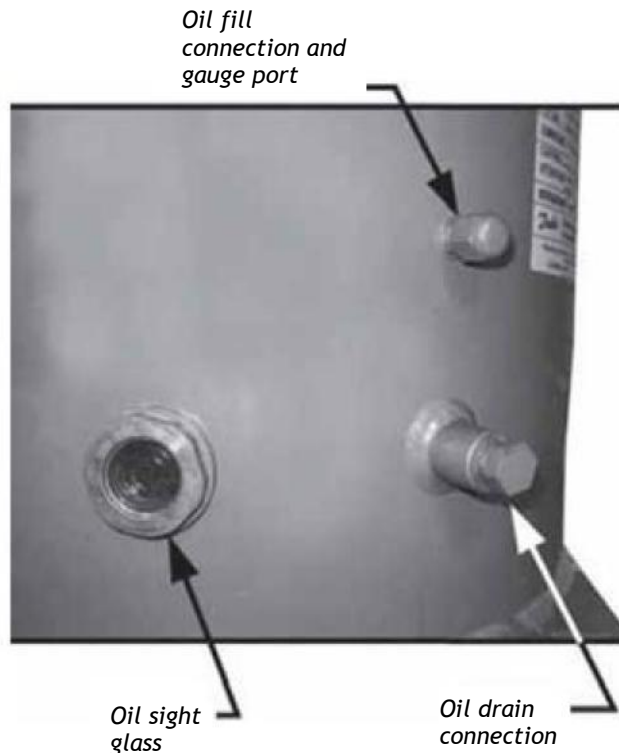

Run for 20 minutes at full load and check the oil level. The CGAF XE units use POE oil.

In case of burns for the electrical motor or fault of the compressor, it is necessary to make a test to check the acidity of the lubricant.

to oil and, eventually, clean the circuit to reduce the acidity to correct values, mounting for instance an antiacid filter and changing the oil in the circuit.

14.3 WARM UP OF THE PLANT

In order to keep all the machine components in good condition and to optimise their use, during the warm up it is necessary to bring the circuit to the right temperature before releasing cooling energy to the utilities.

The following steps must be followed for this to be carried out:

- * start up the machine
- * wait for the water in temperature to reach the running temperature
- * start up the consumers

Follow the above-mentioned procedure every time the plant is stopped long enough for the water temperature contained in it to vary considerably.

14.4 START UP PROCEDURE

- 1) With the switch closed, open the electrical panel and exclude compressor (refer to the wiring diagram on the unit). Close the panel, set switch to "ON" (to give power to the unit).
- 2) Wait for the start of the microprocessor and control. Make sure that the temperature of the oil is hot enough. The oil

temperature must be at least 5°C higher than the saturation temperature of the refrigerant inside the compressor.

3) Place the unit in the "ON" and wait until the unit is indicated on the display-On.

4) Turn on the pump (at max speed if with inverter).

5) Verify that the loss of load of the evaporator is equal to that of the project and correct if necessary.

The pressure drop on the evaporator must be read on the service valves installed on the evaporator piping as a standard. Do not measure the load losses in points where any valves and / or filters are interposed.

6) Check for air in cleaning filters, and then drain the system.

7) Return the pump to the factory setting.

8) Turn off the power (into standby mode) and make sure the pumps stop after about 2 minutes. Verify that the local temperature subcooling is set to the required value by pressing the Set button.

9) Turn the main switch to "OFF". Open the cabinet. Reactivate the compressors. Close the cabinet. Turn the main switch to "ON" (to give power to the unit).

10) Wait for the start of the microprocessor and control.

11) When the compressor is started, wait about 1 minute for the system begins to stabilize.

12) Check the pressure of evaporation and condensation of refrigerant.

13) Verify that, after a period of time necessary for the stabilization of the refrigerant circuit, the liquid indicator placed on the inlet pipe to the expansion valve is completely filled (no bubbles), and that the moisture indicator signs 'Dry'. The passage of bubbles within the liquid indicator may indicate a low amount of refrigerant, or an excessive pressure drop through the filter drier, or an expansion valve blocked at the maximum opening position.

14) In addition to checking the sight glass, check the operating parameters of the circuit controlling:

a) - Overheating compressor

b) - Overheating compressor discharge

c) - Sub cooling of the liquid exiting the condenser coil

d) - Evaporation pressure

e) - Condensing pressure

15) Measure the values of pressure and temperature by means of the suitable instrumentation and make comparison by reading the corresponding values directly on the display of the microprocessor on board

16) To temporarily turn off the unit put on standby the unit key or open the remote contact (terminals shown in the wiring diagram provided with the unit) of the terminal X (by means of a remote switch installed by the customer) or set time zones. The microprocessor will activate the shutdown procedure that will take a few seconds. The unit water pump will be running on for two minutes after the unit has been switched off. Do not remove the main power to not turn off the electrical resistances of the compressor and the evaporator.

15 MAINTENANCE

Maintenance operations are fundamental in order to keep the units running properly, from both a purely functional and an energetic points of view.

Every Trane unit comes with a logbook, in which the user or the person delegated to machine maintenance can keep all the required notes, in order to keep a historical log of the Trane unit.

A lack of notes in the logbook could be considered proof of careless maintenance.

15.1 GENERAL

IMPORTANT!

Beyond the cadences of checks recommended in the following, in order to keep the unit at optimum levels of performance and efficiency and prevent incipient failures, we recommend periodic visits of inspection and control of the unit by qualified personnel.

In particular, we recommend:

4 annual visits to units that operate about 365 days / year (quarterly)

2 visits per year for units with seasonal operation about 180 days / year (one at the start of the season and another one at mid-season)

1 annual visit for units with seasonal operation of about 90 days / year (at the start of the season)

It's important that during the initial start-up and periodically during operation routine checks are carried out. Among them we must also check the suction and condensation as well as the sight glass located on the liquid line.

Check through the microprocessor installed on the unit if the unit is working within normal parameters of superheating and sub cooling. A routine maintenance program recommended is shown at the end of this chapter while a card collection of operating data is at the end of this manual. It is suggested to record on a weekly basis all the operating parameters of the unit. The collection of these data will be very useful to technicians, in case technical assistance is requested



Compressor Maintenance IMPORTANT!

This inspection must be performed by qualified and trained personnel.
The analysis of vibration is a great tool for checking the mechanical conditions of the compressor.
It is recommended to check the value of the vibration immediately after starting and periodically on an annual basis.

Compressor Electrical Connections

It is very important that all the compressors are wired correctly for proper rotation. These compressors will not tolerate reverse rotation. Verify correct rotation/phasing using a rotation meter.
If wired incorrectly the compressor will make excessive noise, will not pump and will draw about half the normal current. It will also become very hot if allowed to run for an extended period.

NOTICE: Do not "bump" the compressor to check rotation as incorrect rotation could cause compressor motor failure in as little as 4 to 5 seconds!

Improper rotation of the compressors is indicated by a compressor module trip, noisy operation, no pressure difference on manifold gauges and low amp draw.

Compressor Replacement

If the chiller suffers a failed compressor, use these steps for replacement:
Each compressor has lifting eyes. Both lifting eyes must be used to lift the failed compressor.
After a mechanical failure of a compressor, it is necessary to change the oil in the remaining compressor and also replace the liquid line filter drier. After an electrical failure of a compressor, it will also be necessary to change the oil in the remaining compressor, replace the filters driers and add a suction filter drier with clean-up cores.
Change filters and oil until the oil no longer test acidic.
Make sure that a heater is correctly installed on the compressor. The heater helps prevent dry starts.
Note: Do not alter the refrigerant piping in any way as this can affect compressor lubrication.

Refrigerant System Open Time

The CGAF XE units use POE oil and therefore refrigerant system open time must be kept to a minimum. The following procedure is recommended:
Leave a new compressor sealed until it is ready to be installed in the unit. Maximum system open time is dependent upon ambient conditions, but do not exceed one hour open time.
Plug the open refrigerant line to minimize moisture absorption. Always change the liquid line filter drier.
Do not leave POE oil containers open to the atmosphere. Always keep them sealed.

15.2 SIGHT CHECK OF THE LIQUID RECEIVER

The risks due to the pressure inside the circuit have been eliminated or (when it is not possible) reduced by means of safety devices. It is important to check periodically the status of this device and to carry out the components inspections and repositioning as follows.
Check the liquid receiver state at least one a year.
It is important to check that the surface does not get rusty and that neither corrosion nor deformations are visible.
In case the superficial oxidation and the corrosion are not properly controlled and stopped in time, cause a thickness reduction with a consequent reduction of the receiver mechanical resistance.
Use antioxidant paint or products to protect.

15.3 STANDARD CONTROLS

It is mandatory to clean regularly the coils for a proper unit operation. Pollution and other residual material clearing helps extend the life of the coils and the whole unit

Operations description	Recommended basis
Compressors oil level check	monthly
Inlet temperature check (overheating)	monthly
Water circuits filling check	monthly
Fans and compressors motors electrical input check	monthly
Power supply and auxiliary power voltage check	monthly
Refrigerant charge check through sight glass	monthly
Compressors carter heaters operation check	monthly
Tightening all electrical connections	monthly
Coils cleanliness	monthly
Compressors and liquid circuit solenoid valve	semiannua
Fans and compressors contactors state check	quarterly
Evaporator heater operation check	quarterly
Motor and fan bearing noise check	semiannual
Pressure vessels conditions check	yearly

Temperature and pressure probes – The unit comes factory-equipped with all the sensors listed below. Periodically check that their measurements are correct by means of sample instruments (manometers, thermometers); correct readings if necessary using the microprocessor keyboard. Well- calibrated sensors ensure better efficiency for the unit and a longer lifetime.

Note: refer to the microprocessor use and maintenance manual for a complete description of applications, setting and adjustments.

All sensors are preassembled and connected to the microprocessor. The descriptions of each sensor are listed below:

Outgoing water temperature sensor –This sensor is located on the evaporator outgoing water connection and is used by the microprocessor for antifreeze protection and to control the unit load according to the system thermal load.

IMPORTANT

In case a temperature control based on ingoing water temperature is needed please contact Trane before carrying out any trying to set it [autonomously](#).

Ingoing water temperature sensor –This sensor is located on the evaporator ingoing water connection and is used for monitoring the return water temperature.

External air temperature sensor –This sensor allows to monitor the external air temperature on the microprocessor display.

High pressure transducer –This allows to monitor the delivery pressure and to control the ventilators on each circuit. Should an increase in condensation pressure occur, the microprocessor will control the circuit load in order to allow it to function even if choked. It contributes to complementing the oil control logic.

Low-pressure transducer –This allows to monitor the compressor suction pressure along with low pressure alarms on each circuit. It contributes to complementing the oil control logic.

15.4 MICROCHANNEL CONDENSER COIL – CLEANING PROCEDURES

It is mandatory to clean regularly the coils for a proper unit operation. Eliminate pollution and other residual material help to extend the life of the coils and the unit

CAUTION! Equipment Damage! Do not use coil cleaning agents to clean uncoated CGAF XE coils. Use clean water only. Use of coil cleaning agents on uncoated CGAF XE coils could cause damage to coils.

- Regular coil maintenance, including annual cleaning enhances the unit operating efficiency by minimizing compressor head pressure and amperage draw. The condenser coil should be cleaned at least once each quarter or more if the unit is located in a “dirty” or corrosive environment. Cleaning with cleansers or detergents is strongly discouraged due to the all-



aluminum construction; straight water should prove sufficient, if not please contact Trane. Any breach in the tubes can result in refrigerant leaks

IMPORTANT: *Only in extreme cases should any type of chemical cleaner or detergent be used on microchannel coils. If it becomes absolutely necessary because water alone did not clean the coil, specify a cleaner that is:*

- A is pH neutral cleaner.
- An alkaline cleaner that is no higher than 8 on the pH scale.
- An acidic cleaner that is no lower than 6 on the pH scale.
- Does not contain any hydrofluoric acids.

Be sure to follow the instructions provided with any cleaner chosen. Keep in mind that it is still MANDATORY that the coils are thoroughly rinsed with water after the application of the cleaner even if the instructions specify a "No Rinse" cleaner. Cleaners or detergents that are left on the coil due to improper rinsing will significantly increase the possibility of corrosion damage on the microchannel coil.

Note: Quarterly cleaning is essential to extend the life of an E-coated coil and is required to maintain warranty coverage. Failure to clean an E-coated coil will void the warranty and may result in reduced efficiency and durability in the environment.

WARNING! Hazardous Voltage!

Disconnect all electric power, including remote disconnects before servicing. Follow proper lockout/ tagout procedures to ensure the power cannot be inadvertently energized. Failure to disconnect power before servicing could result in death or serious injury.

1. Disconnect Power to the unit.
2. Wear proper personal protection equipment such as a face shield, gloves and waterproof clothing.
3. Remove enough panels from the unit to gain safe access to the microchannel coil.

15.5 ORDINARY MAINTENANCE

Activities list	week	Month (note 1)	Year (note 2)
General:			
Data collection operation (Note 3)	X		
Visually inspect the unit for any damage and / or looseness		X	
Verifying the integrity of the thermal insulation			X
Clean and paint where needed			X
Water Analysis (6)			X
Electric:			
Check the correct operation of the equipment on the unit			X
Check the wear of contactors - Replace if necessary			X
Check tightness of all electrical terminals - Tighten if necessary			X
Clean the inside of the electrical panel			X
Visual inspection of the components for signs of overheating		X	
Check the operation of the compressor and the electric resistance		X	
Measurement using a Megger insulation of the compressor motor			X
Refrigerant circuit:			
Perform a test of refrigerant leaks		X	
Check through the sight glass coolant flow - Full Indicator	X		
Check the pressure drop of the filter drier		X	
Check the pressure drop of the oil filter (Note 5)		X	
Carry out the analysis of the vibrations of the compressor			X
Carry out the analysis of the acidity of the oil of the compressor (7)			X
Condensing section:			
Cleaning the condenser coils (Note 4)			X
Check that the fans are tightened			X
Check the fins of coils – comb it if necessary			X

Notes:

- 1) The monthly activities include all those weekly.
- 2) The annual activity (or earlier in the season), include all activities weekly and monthly.
- 3) The values of the unit should be recorded each day for a high level of observation.
- 4) The coil cleaning may be required more frequently in areas with a high percentage of particles in the air.
- 5) Replace the oil filter when its pressure drop reaches 2.0 bar.
- 6) Check for dissolved metals.
- 7) No action

Number): 0.10: TAN (Total Acid)
 Repositioning filters antacid and occurs after 1000 hours of operation. Continue to replace the filters until the TAN not falls below 0.10.

> 0.19: Changing the oil, oil filter and the filter drier, Refer to regular intervals.



16 RECOMMENDED SPARE PARTS

There follows a list of the recommended parts for several years' running. Trane is at your disposal to recommend a personalised list of accessories according to the commissioned order, including the part number of the equipment.

1 YEAR		2 YEAR		5 YEAR	
COMPONENTS	QUANTITY	COMPONENTS	QUANTITY	COMPONENTS	QUANTITY
fuses	(all)	fuses	(all)	fuses	(all)
filter dryers	(all)	filter dryers	(all)	filter dryers	(all)
solenoid valves	(1 per type)	solenoid valves	(all)	solenoid valves	(all)
electronic expansion valves	(1 per type)	electronic expansion valves	(all)	electronic expansion valves	(all)
pressure switches	(1 per type)	pressure switches	(all)	pressure switches	(all)
gas gauges	(1 per type)	gas gauges	(all)	gas gauges	(all)
contactors and relays	(1 per type)	contactors and relays	(all)	contactors and relays	(all)
thermal protectors	(1 per type)	thermal protectors	(all)	thermal protectors	(all)
carter electric heaters	(1 per type)	carter electric heaters	(all)	carter electric heaters	(all)
check valve	(1 per type)	check valve	(1 per type)	check valve	(all)
sight glass	(1 per type)	sight glass	(1 per type)	sight glass	(all)
fans and engines	(1 per type)	fans and engines	(1 per type)	fans and engines	(all)
		electrical components	(all)	electrical components	(all)
		compressors	(1 per type)	compressors	(all)
				heat exchanger	(1 per type)

17 TROUBLESHOOTING

	Symptom Cooling	Who can take corrective action U = User S = specialised personnel	Probable cause	Possible remedy
A The unit does not start	X	S	Probe faulty service	Check and replace if necessary.
	X	S	Lack of consent of the high or low pressure	See points D-E
	X	S	Defective compressor	See point B.
B The compressor does not start	X	S	Compressor burnt or seized	Replace the compressor.
	X	S	Compressor contactor de-energized	Check the voltage across the coil of the compressor contactor and the continuity of the coil.
	X	S	Power circuit open	Investigate the cause of the protection, and check if there are any short circuits in the wiring or in the windings of the motors of pump, fan, compressor and transformer
	X	S	Motor thermal protection open	The compressor has operated in critical condition or there is a lack of charge in the circuit: Make sure that working conditions are within the limits of operation. Loss of coolant: see section G.
C The compressor starts up and stops repeatedly	X	S	Intervention of the minimum	See point E.
	X	S	Compressor contactor defective	Check and replace if necessary.
	X	U	Calibration values of the set-point or differential	Modify them as reported in the in the tables.
	X	S	Lack of coolant	See point G
D The compressor does not start because the maximum pressure switch has tripped	X	S	Pressure switch out of order	Check and replace.
	X	S	Overcharge of refrigerant	Download the excess refrigerant
	X	U	Finned coil clogged, air flow rate is too low	Remove dirt from the coil and obstructions to the air flow
	X	S	Fan not working	See point F.
		S	Water pump circulation blocked	Unblock the pump.
		X	Water circulation pump and defective	Check and replace if necessary.
	X	S	Presence of non condensable gases in the refrigerant circuit	Prime the circuit after it has been downloaded and put under vacuum.
X	S	Refrigerant filter clogged	Check and replace	

Symptom	Who can take corrective action		Probable cause	Possible remedy
	Cooling	U = User S = specialised personnel		
E The compressor does not start because the minimum pressure switch has tripped	X	S	Pressure switch out of order	Check and replace.
	X	S	Machine completely void of refrigerant	See point G.
		U	Finned coil clogged, airflow rate is too low	Remove dirt from the coil.
	X	U	Water circulation pump blocked	Unlock the pump
	X	S	Water circulation pump blocked and defective	Check the pump and replace if necessary
		S	Presence of frost on the evaporator coil	See point N.
		S	Evaporator fan not working	See point F.
	X	S	Refrigerant filter clogged	Check and replace.
	X	S	Expansion device that is not working properly	Check and replace if necessary.
	S	Presence of moisture in the refrigerant circuit	Replace the filter, dry and recharge	
F The fans do not start	X	S	Fan contactor de-energized	Check the voltage across the coil of the contactor and the continuity of the coil.
	X	S	Lack of output voltage from the control fan speed	Check the contacts, replace if necessary
	X	S	Thermal protection inside the fan	Check the condition of the fan and the air temperature during operation of the unit.
	X	S	Fan motor faulty	Check and replace.
	X	S	Loose electrical connections	Check and replace.
G Lack of gas	X	S	Loss in the refrigerant circuit	Check the cooling circuit using a leak detector after pressurising the circuit to approximately 4 bars. Repair, evacuate and refill.
H Frost in the liquid line downstream from a filter	X	S	The filter is clogged	Replace the filter
I The unit works continuously without ever stopping	X	S	Lack of refrigerant gas	See item G.
	X	U	Incorrect tuning of the operating thermostat	Check and set.
	X	S	Excessive thermal load	Reduce the thermal load
	X	S	Compressor does not give the thermal output	Check, change or revise
	X	S	The liquid filter is clogged	Replace.
L The unit works regularly but with an insufficient capacity	X	S	Low refrigerant charge	See point G.

Symptom	Cooling	Who can take corrective action U = User S = specialised personnel	Probable cause	Possible remedy
M Frost in the compressor intake pipe	X	S	Expansion device that is not working properly	Verify and replace.
	X	S	Water circulation pump blocked	Unlock the pump.
	X	S	Water circulation pump defective	Check the pump and replace if necessary.
N Abnormal noise detected in the system	X	S	Compressor noisy	Check and replace if necessary.
	X	S	The panel vibrate	Fasten properly.
O The unit does not start	X	S	Low refrigerant charge	See point G.
	X	S	The liquid filter is clogged	Replace.
O The unit does not start	X	S	Phases of the supply network reversed	Invert two phases.



TRANE®

Trane — by Trane Technologies (NYSE: TT), a global climate innovator — creates comfortable, energy efficient indoor environments through a broad portfolio of heating, ventilating and air conditioning systems and controls, services, parts and supply. For more information, please visit trane.eu or tranetechnologies.com.

© 2021 Trane All rights reserved trane.eu CG-SVX058B-GB_0522 Supersedes CG-SVX058A-GB_1221

We are committed to using environmentally conscious print practices that reduce waste.

Commercial Clarifications

AVAILABILITY

The current availability of the proposed equipment is indicated below. Manufacture can only commence after receipt and clearance of full written instructions with all of the details required for immediate release for production and eventual delivery. Manufacturing cycles are subject to change and should be checked at the time of order placement.

12-14 working weeks

DELIVERY

Prices allow for weekday delivery on standard vehicles during normal working hours (0700 to 1800 Hrs.). Delivery charges for vehicles equipped with off-loading facilities and/or delivery out of normal working hours are available on request.

The standard times included for off-loading, and the demurrage charges thereafter, are: -
First 2 Hrs. free / from £102 per hour plus V.A.T. thereafter.

A weekend delivery service on standard vehicles during normal working hours is available if required. There is an additional net charge for this service that can be quoted on request.

COMMISSIONING

Where commissioning is included this will be carried out by TRANE and is inclusive of travel, accommodation (if applicable) and labour unless stated elsewhere. If commissioning progress is delayed whilst on site through no fault of TRANE all additional days required to complete the commissioning will be charged as extras at £910 per day plus accommodation expenses (if applicable).

ENVIRONMENTAL PROTECTION ACT

Under the requirements of the Environmental Protection Act all TRANE Service Engineers are registered with the Refrigeration Industry Board and are fully qualified and equipped to handle refrigerant gases and oils. Discharge of refrigerants to atmosphere is now a criminal offence, and both the Employer and the Contractor are liable to prosecution. It is advisable, therefore, to use only qualified personnel for specialised service work such as commissioning and maintenance etc.

TERMS OF PAYMENT

30 Days End of Month. Subject to credit approval.

VALIDITY

30 Days from the date shown on the front letter.

WARRANTY PERIOD

The warranty period included in this proposal is 24 months from date of shipment. An extended warranty period, and/or delayed start up cover, to suit individual customer requirements can be purchased at the time of placing the equipment on order. Our warranty cover as described in section 14 of our 'Conditions of Sales of Goods and Services' [printed on the reverse of our proposal and/or available upon request] will not apply to goods which are not maintained by Trane or its authorised representative in accordance with Trane's instructions. The equipment must be regularly maintained throughout the warranty period to validate and preserve the warranty. Failure to respect installation and maintenance instructions may result in cancellation of the warranty. Prices for alternative warranty periods and maintenance contracts are available upon request.

Regional offices at:

Sefton House, Middlebrook Business Park, Bolton, BL6 6PQ
Unit 54 Grayhill Road, Westfield North, Cumbernauld, North Lanarkshire, G68 9HQ



ABOUT US

Trane, designs, manufactures and services HVAC-R systems and controls to create and sustain safe, comfortable and efficient work environments for buildings and industrial processes.

We take great pride in the expertise we have built over decades and use it to deliver exactly the solutions our customers need to meet their business objectives by reducing energy consumption and costs.



Trane doesn't just follow industry standards. We define them.

Buildings. They're the environments in which we live and work, learn and play, heal and grow. And Trane makes high performance buildings better for everyone inside. Our innovative solutions create spaces that are reliable and safe, as well as healthy, comfortable and efficient – which in turn yields greater productivity and profitability.

Trane also improves the life of the building itself.

Trane also improves the life of the building itself. We collaborate with building owners and operators to create high performance buildings that contribute measurable, year-over-year benefits and support mission-critical objectives. Together, we explore the mission of the organization within the building itself, along with its strategic and financial objectives, and the inevitable challenges that come with improving building performance. And we work together to determine the ways the building environment impacts the organization for the better.



Regional offices at:

Sefton House, Middlebrook Business Park, Bolton, BL6 6PQ
Unit 54 Grayhill Road, Westfield North, Cumbernauld, North Lanarkshire, G68 9HQ

TRANE UK LIMITED – CONDITIONS OF SALE OF TRANE'S GOODS AND SERVICES

1. INTERPRETATION

"Applied Equipment" means Goods sold to the Buyer requiring Commissioning by Trane or by a third party provider approved by Trane;

"Buyer" means the Company, person or firm as detailed in the Proposal to whom Goods and/or Services are to be supplied;

"Commencement Date" means the date on which the Buyer's offer is accepted by Trane;

"Conditions" means these terms and conditions including the Proposal and any Schedules hereto;

"Commissioning" means Trane's establishment that the Goods are correctly installed and configured at the Site;

"Contract" means the contract subject to the Conditions for the provision of Services and/or for the supply of Goods made between Trane and the Buyer;

"Equipment" means the equipment listed in the Proposal in respect of which Trane will provide the Services;

"Goods" means the goods, materials and/or other items as set out in the Proposal to be supplied pursuant to the Contract;

"Parts" means Goods which are component parts sold to the Buyer for the Buyer to install which are to replace worn, broken or defective components;

"Price" means the price of Goods and/or Services as set out in the Proposal subject to Clauses 5.2 and 5.3;

"Proposal" means the proposal given by Trane for the sale of Goods/supply of Services which is subject to these Conditions;

"Services" means the Services set out in the Proposal;

"Service Level" means the level of Services chosen by the Buyer [in accordance with Trane's published description of the Services] and as indicated in the Proposal for each item of Equipment listed therein;

"Site" means the location(s) specified in the Proposal for the delivery of the Goods or Services;

"Trane" means TRANE UK LIMITED of registered office Harrow House, Bessemer Road, Basingstoke, Hampshire RG21 3NB registered no. 03275303;

"Maintenance Guide" means a document described as "Trane Maintenance Guide" as produced by Trane and which sets out a maintenance timetable and maintenance routine specific to the equipment therein described;

"Unitary Equipment" means Goods, other than Applied Equipment, remanufactured compressors or Parts, sold to the Buyer for the Buyer to install;

"Writing" includes manuscript, type-written or printed statement (under seal or hand as the case may be), facsimile transmission and electronic mail.

2. PROPOSAL VALIDITY PERIOD

Unless previously withdrawn, any Proposal submitted by Trane shall be valid for a period of 30 days from the date thereof.

3. FORMATION OF CONTRACT

- Except where these Conditions are varied in accordance with Clause 3.3, these Conditions shall apply to any Contract entered into between the Buyer and Trane to the exclusion of all other terms and conditions (including any terms or conditions which the Buyer purports to apply under any order or other document), whether referred to in previous dealings or discussions, or implied by law or otherwise, and constitute the entire agreement between the parties.
- No contract shall come into being until Trane has accepted the Buyer's order for Goods or Services in Writing and confirmed the content of the Proposal.
- No variation to any of these Conditions shall be incorporated into these Conditions unless agreed by the authorised representatives of each of the parties in Writing and the parties acknowledge that these Conditions (with the incorporation of any such variations) constitute the entire agreement between the parties.
- Any typographical, clerical or other error or omission in any sales literature, proposal, price list, acceptance of order, drawings, specifications, invoice or other document or information issued by Trane shall be subject to correction without any liability on the part of Trane.
- Any advice or recommendation given by Trane to the Buyer in relation to the Goods/Services, which is not confirmed in Writing by a duly authorised representative of Trane, is followed or accepted by the Buyer entirely at the Buyer's own risk and Trane shall not be liable for any such advice or recommendation which is not so confirmed.

4. TERM

In respect of the provision of Services (if any) under the Contract, the Contract shall commence on the Commencement Date and, subject to earlier termination in accordance with Clause 16, shall continue unless terminated by either party on no less than 3 months prior notice in Writing to the other, such notice to expire on the anniversary of the Commencement Date.

5. CONTRACT PRICE

- The Price payable for the Goods and the Services shall be that set out in the Proposal.
- Trane shall be entitled at any time and from time to time to increase the Price referred to in Clause 5.1 by giving notice in Writing to the Buyer at any time prior to the delivery of Goods or any part of the Services to reflect any increase in Trane's cost in performing the Contract which is due to any factor beyond Trane's control (such as, without limitation, any foreign exchange fluctuation, currency regulation, alteration of import/export duties, increase in the cost of labour, materials or costs of manufacture or performance) any change in quantities or specification of the Goods or Services requirements requested by the Buyer or failure to give Trane adequate information or instructions.
- In addition to any alteration under Clause 5.2, where the Contract is for the provision of Services, Trane may increase the Price:
 - on each anniversary of the Commencement Date by a percentage equal to the percentage increase in the Retail Prices Index published by the Office for National Statistics for each period of 12 months from the Commencement Date plus 2 per cent, without notice to the Buyer; and from time to time as reasonably required by Trane for any reason by serving 30 days' notice in Writing to the Buyer.
- In the event that the proposed increase to the Price for Services under Clause 5.3.2 is not accepted by the Buyer, the Buyer may within 30 days' of receipt of such notice, give notice in Writing to Trane to terminate the Contract.
- Trane reserves the right to charge the Buyer, in addition to the Price, the reasonable cost of restocking any Goods requested by the Buyer.
- Unless otherwise agreed by Trane in Writing, the Price includes freight costs to the Site and insurance while the Goods are in transit.
- The Price is exclusive of any Value Added Tax or any other tax or duty payable and the Buyer will bear the cost of any such tax or duty in addition to the Price.
- The Buyer will ensure that the Site is prepared to enable Trane to deliver the Goods and/or perform the Services, and to enable the Buyer to accept delivery or performance of the same, including, without limitation, arranging access to the Site, providing cranes, hoists or other safety equipment, utilities, other services and workmen. In the event that the Site is not prepared as required by this Clause 5.8, at the time of delivery of the Goods or performance of the Services, Trane may arrange any equipment or services necessary to prepare the Site for delivery by Trane and acceptance by the Buyer and charge the cost of such equipment and services and any associated administration charges, to the Buyer in accordance with Clause 10, and/or store and maintain the Goods in accordance with Clause 7.5 until the Buyer has prepared the Site and an alternative delivery date has been agreed.
- The Buyer will indemnify Trane against all costs, charges expenses, actions, suits, claims and demands in connection with any equipment or services arranged by Trane under Clause 5.8.
- Where the Buyer requests Goods or Services outside of those referred to in the Proposal then Trane shall be entitled to charge for such in accordance with its then current pricing structure.

6. TRANSFER OF TITLE AND RISK

- Risk in the Goods and all liability to third parties in respect thereof shall pass to the Buyer on delivery to the carrier as per CIP (Incoterms 2000).
- Ownership of the Goods shall not pass to the Buyer:
 - At all where Clause 7.5 applies;
 - (In other situations) until Trane has received in full (in cash or cleared funds) all sums due to it in respect of:
 - the Goods; and
 - all other sums which are or which become due to Trane from the Buyer on any account.
- Until ownership of the Goods has passed to the Buyer, the Buyer must:
 - hold the Goods on a fiduciary basis as Trane's bailee;
 - store the Goods (at no cost to Trane) separately from all other goods of the Buyer or any third party in such a way that they remain readily identifiable as Trane's property;
 - not destroy, deface or obscure any identifying mark on or relating to the Goods;

- maintain the Goods in satisfactory condition insured on Trane's behalf for their full price against all risks to the reasonable satisfaction of Trane. On request the Buyer shall produce the policy of insurance to Trane; and
 - hold the proceeds of the insurance referred to in condition 6.3.4 on trust for Trane and not mix them with any other money, nor pay the proceeds into an overdrawn bank account.
- The Buyer may resell the Goods before ownership has passed to it solely on the following conditions:
 - any sale shall be effected in the ordinary course of the Buyer's business at full market value and the Buyer shall hold such part of the proceeds of sale as represent the amount owed by the Buyer to Trane on behalf of Trane and the Buyer shall account to Trane accordingly;
 - such part of the proceeds of any sale as represent the amount owed to Trane are held on trust for Trane and will not be mixed with any other money nor paid into an overdrawn bank account, but be placed in a separate bank account in Trane's name;
 - any such sale shall be a sale of Trane's property on the Buyer's own behalf and the Buyer shall deal as principal when making such a sale; and
 - actual delivery of the Goods to the Buyer has been effected.
 - The Buyer's right to possession of the Goods shall terminate immediately if:
 - The Buyer, has a bankruptcy order made against him or makes an arrangement or composition with his creditors, or otherwise takes the benefit of any Act for the time being in force for the relief of insolvent debtors, or (being a body corporate) convenes a meeting of creditors (whether formal or informal), or enters into liquidation (whether voluntary or compulsory) except a solvent voluntary liquidation for the purpose only of reconstruction or amalgamation, or has a receiver and/or manager, administrator or administrative receiver appointed of its undertaking or any part thereof, or a resolution is passed or a petition presented to any court for the winding up of the Buyer or for the granting of an administration order in respect of the Buyer, or any proceedings are commenced relating to the insolvency or possible insolvency of the Buyer or if the Buyer suffers any similar or analogous action (in any jurisdiction) in consequence of debt; or
 - The Buyer suffers or allows any execution, whether legal or equitable, to be levied on his/its property or obtained against him/it, or fails to observe/perform any of his/its obligations under the Contract or any other contract between Trane and the Buyer, or is unable to pay its debts within the meaning of sections 123 or 268 of the Insolvency Act 1986 (as appropriate) or the Buyer ceases to trade; or
 - the Buyer encumbers or in any way charges any of the Goods.
 - Trane shall be entitled to recover payment for the Goods notwithstanding that ownership of any of the Goods has not passed from Trane.
 - The Buyer grants Trane, its agents and employees an irrevocable licence at any time to enter any premises where the Goods are or may be stored in order to inspect them, or, where the Buyer's right to possession has terminated, to recover them.
- ## 7. DELIVERY
- Trane will issue notice in Writing to the Buyer when the Goods are available for delivery to the carrier.
 - Removal from their transportation vehicle(s), installation and positioning of the Goods is the responsibility of the Buyer and Trane accepts no liability for removing the goods from the transportation vehicle or installation or positioning.
 - Delivery of Goods is subject to availability and time for delivery shall not be of the essence. Trane shall not be responsible for any failure to meet proposed or agreed delivery dates.
 - If for any reason either the carrier will not accept delivery as per Clause 6.1 or Trane is unable to deliver the Goods because the carrier has not provided appropriate instructions, documents, licences or authorisations (in either case a "Failed Delivery"):
 - the Goods will be deemed to have been delivered and risk in the Goods will pass to the Buyer (including for loss or damage caused by Trane's negligence);
 - Trane may store and maintain the Goods until actual delivery to Site and the Buyer will be liable for all related costs and expenses (including, without limitation, storage and insurance) in accordance with Clause 10;
 - Within 7 days of the Failed Delivery Trane shall notify the Buyer in Writing of a new delivery date ("New Date") which shall be a date no later than 6 months after the Failed Delivery;
 - Where Trane chooses to store Goods until actual delivery, the Buyer will be liable for all costs and expenses associated with re-delivering the Goods on all occasions that Trane tenders delivery.
 - Provided that the Buyer notifies Trane in Writing that the Goods are ready for Commissioning, Trane will attend the Site to undertake Commissioning of the Goods.
 - Time for Commissioning will not be of the essence and in the event that the Goods are found to be faulty during the Commissioning process then, subject to Clause 7.8, Trane will use reasonable endeavours to obtain replacement parts, install them and complete Commissioning within a reasonable time.
 - Trane accepts no responsibility for Commissioning where the Goods are, in Trane's opinion:
 - not installed correctly;
 - accidentally or deliberately misused by the Buyer or any third party;
 - not stored or used at the correct temperature or humidity;
 - not maintained by the Buyer in accordance with Trane's instructions;
 - damaged by any other act beyond Trane's control, and in these circumstances Trane will only undertake Commissioning under a separate Contract for Services. Any dispute under this Clause 7.8 shall be referred to expert determination, such expert to be agreed between the parties and whose decision shall be binding on the parties.
- ## 8. PERFORMANCE OF SERVICES AND EXTENDED WARRANTY
- The Services will be performed in respect of each item of Equipment listed in the Proposal and in accordance with the Service Level and relevant Trane Maintenance Guide.
 - Acceptance by Trane of any item of Equipment into a Contract does not imply that it is installed satisfactorily or to Trane's prevailing standards.
 - Trane will use its reasonable endeavours to carry out the first Inspection Visit under the relevant Maintenance Guide for each item of Equipment within 28 days of the Commencement Date or as otherwise agreed.
 - Trane reserves the right following the first Inspection Visit to cancel the Contract for Services in whole or part where any item of Equipment in Trane's opinion is not in good condition and working order and/or where to provide the Services would be unsafe or where the Equipment cannot be accessed to provide the Services. In such circumstances Trane will refund to the Buyer the element of the price relating to the item(s) of Equipment where Trane will not provide Services less the costs of the first Inspection Visit and administration costs incurred by Trane in relation to cancelling the Contract.
 - Trane will use reasonable endeavours to ensure that:
 - only qualified Trane personnel work on the Equipment and that where appropriate Trane engineers are all qualified to City and Guilds 2077 and 2078 in Refrigerant Handling Procedures and are registered with the Refrigeration Industry Board;
 - response times agreed in Writing are met.
 - The Services exclude any maintenance of the Equipment which is necessitated as a result of any cause other than fair wear and tear, including without limitation:
 - failure or fluctuation of electric power, or other environmental conditions; or accident, neglect, misuse or default of the Buyer, its employees or agents or any third party;
 - act of God, fire, flood, war, act of violence, or any other similar occurrence; or
 - any attempt by any person other than the Supplier's personnel to adjust, repair or maintain the Equipment;
 - cost of replacement parts, gaskets, refrigerant and other materials or consumables not included in the Proposal (and such items will be invoiced in addition to the Price).
 - Trane will (if it is reasonably able to do so) at the request and expense of the Buyer repair or replace any part of the Equipment which has failed due to a cause other than fair wear and tear subject to the Buyer accepting Trane's written quotation therefore prior to the commencement of work.
- ## 9. ACCEPTANCE OF SERVICES
- The Buyer is deemed to accept that the Services or any part thereof have been delivered to the Buyer's satisfaction unless Trane is notified in Writing to the contrary within 5 working days of Trane's delivery of a Notification of Completion ("the Worksheet") signed by Trane's authorised representative.
 - At its discretion, Trane will deliver the Worksheet either:
 - by hand at the Site; or
 - by post or e-mail
 - and such delivery of the Worksheet is conclusive evidence that Trane has attended the Site and performed its obligations, or part thereof, under the Contract.

10. TERMS OF PAYMENT

TRANE UK LIMITED – CONDITIONS OF SALE OF TRANE'S GOODS AND SERVICES

- 10.1 Subject to Clause 10.9.3 or any variation provided in the Proposal, amounts owing to Trane under the Contract shall be paid in Pounds Sterling (£) and shall be due and payable within 30 days of invoice date.
- 10.2 Trane reserves the right to grant to and remove from the Buyer any credit period agreed in Writing whether in the Proposal, these Conditions or otherwise, by issuing notice in Writing to the Buyer. On issue of such notice by Trane, the Price shall become payable forthwith in full by the Buyer.
- 10.3 Trane reserves the right at any time:
- 10.3.1 to require the Buyer to provide such security or guarantee in respect of any credit advanced to the Buyer under this Contract as Trane may in its absolute discretion deem necessary; or
- 10.3.2 to vary the terms and conditions of any credit advanced to the Buyer without notice.
- 10.4 Time for payment of the Price and all other sums due under the Conditions shall be of the essence.
- 10.5 No payment shall be deemed to have been received until Trane has received cleared funds.
- 10.6 All payments payable to Trane under the Contract shall become due immediately upon termination of this Contract.
- 10.7 The Buyer shall make all payments due under the Contract without any deduction whether by way of set-off, counterclaim, discount, abatement or otherwise.
- 10.8 Trane reserves the right to suspend further deliveries of any Goods or performance of Services under this or any other Contract with the Buyer in the event of late or non-payment.
- 10.9 In the event that Trane exercises its rights under Clause 10.8 above Trane:
- 10.9.1 is entitled to remove from the Site all its equipment, materials and other property brought onto the Site by its employees;
- 10.9.2 may charge the Buyer the value of the Goods/Services delivered/executed prior to suspension along with the cost of any items and service supplied in accordance with Clauses 5.8, 7.5 and 7.6; and
- 10.9.3 all sums under this Clause 10.9 are payable immediately on presentation by Trane of an invoice for the same.
- 10.10 If the Buyer fails to pay the Company any sum due pursuant to the Contract the Buyer will be liable to pay interest to the Company on such sum from the due date for payment at the annual rate of 3% above the base lending rate from time to time of Lloyds Bank plc accruing on a daily basis until payment in cleared funds is made, whether before or after any judgment.
- 10.11 The Company reserves the right to claim interest and fixed sum compensation under the Late Payment of Commercial Debts (Interest) Act 1998.
- 10.12 The Buyer will indemnify Trane against all costs and expenses incurred as a result of any breach of the Buyer's payment obligations in Clauses 5, 7 and 10 including (without prejudice to the generality of the foregoing) legal fees in obtaining payment.
- 10.13 If the Buyer requires Trane to perform any services in excess of those set out in the Service Level, Trane reserves the right to make additional charges as appropriate and in accordance with these Conditions at Trane's then current charge out rate.
- 11. TRANE'S EQUIPMENT**
- 11.1 The Buyer will store, free of charge, all materials, tools, plant machinery and other property brought on to the Site by Trane for the purposes of the Contract.
- 11.2 The Buyer will indemnify Trane against all loss or damage and against all actions, suits, claims, demands, costs, charges and expenses which may arise from the storage or use of such equipment at the Site, however remote.
- 12. ACCESS TO THE SITE**
- 12.1 Trane's employees, subcontractors and agents will be given free and continuous access to the Site and use of services on Site as reasonably required by Trane to perform the Services or deliver or Commission the Goods.
- 12.2 In the event that access to the Site is refused for any reason, the Buyer will pay all of Trane's cost in performing the Services or delivering or Commissioning the Goods caused by the refusal of access, including, but not limited to the cost of re-attending the Site, re-supply of Goods or Services, associated administration charges and all other costs and expenses.
- 12.3 Trane will use reasonable endeavours to ensure its employees, subcontractors and agents comply with the Buyer's site rules and relevant health and safety standards.
- 12.4 The Buyer will notify Trane in advance of any unusual operating conditions which may affect Trane's performance of the Services or delivery or Commissioning of Goods.
- 13. DRAWINGS AND SPECIFICATIONS**
- 13.1 All drawings and specifications relating to the Goods/Services wheresoever contained are approximate only and do not form part of the Contract and Trane accepts no liability for the design of the Goods or accuracy of such drawings and specifications.
- 13.2 Trane retains all its intellectual property rights in all such drawings and specifications including any drawing created for the Buyer for the purposes of the Contract.
- 13.3 Trane shall, if requested by the Buyer, supply free of charge up to five copies of general arrangement drawings of the Goods.
- 13.4 As a result of continuing development and improvement, the drawings relating to Goods and any specification relating thereto may vary from those given in Trane's current catalogue.
- 14. STANDARD WARRANTY**
- 14.1 Except where Clauses 14.2 or 14.3 apply:
- 14.1.1 Applied Equipment supplied pursuant to this Contract shall be guaranteed as regards parts and labour (including refrigerant) against all defects of workmanship and/or materials for a period of 24 months from actual delivery (in accordance with Clause 7).
- 14.1.2 Parts and Unitary Equipment supplied pursuant to this Contract shall be guaranteed as regards replacement against all defects of workmanship and/or materials for a period of 24 months from the date of delivery;
- 14.1.3 Remanufactured compressors supplied pursuant to this Contract shall be guaranteed against all defects of workmanship and/or materials as regards replacement parts and labour for a period of 18 months from the date of delivery; provided in each of the above situations that Trane has received Written notice of such defect within the Warranty Period.
- 14.2 Replacement Goods provided under any of the provisions of Clause 14.1 shall be guaranteed for the unexpired period of the original Warranty Period only.
- 14.3 The guarantee in Clause 14.1 will not apply to Goods which are:
- not maintained by Trane or its authorised representative or other qualified engineer, qualified to City and Guilds 2077, 2078 and 2079 in Refrigerant Handling Procedures and registered with the Refrigeration Industry Board; or NVQ mechanical engineering services – small commercial/refrigerant and air conditioning system Level 2 (Q1027260) and in accordance with Trane's instructions with up to date maintenance records;
- 14.3.1 not stored or used at the recommended temperature or humidity;
- 14.3.2 not installed correctly;
- 14.3.3 accidentally or deliberately misused by the Buyer;
- 14.3.4 damaged by any other act beyond Trane's control;
- 14.3.5 replacement Goods not installed by Trane or its authorised representative.
- 14.4 In the event of a claim under Clause 14.1 Trane has the right to inspect the Goods in order to decide whether the guarantee applies to the Goods in accordance with Clause 14.3. Any dispute under this Clause shall be referred to expert determination, such expert to be agreed between the parties and whose decision shall be binding on the parties.
- 14.5 Subject to conditions 14.3 and 14.4, if any of the Goods do not conform with the guarantee at Clause 14.1 Trane shall at its option repair or replace such Goods (or the defective part) or if the Goods (or defective part) cannot be repaired or replaced for any reason, refund the price of such Goods provided that, if Trane so requests, the Buyer shall, at Trane's reasonable expense, return the Goods or the part of such Goods which is defective to Trane.
- 14.6 If Trane complies with Clause 14.5 it shall have no further liability for a breach of warranty in Clause 14.1 in respect of such Goods.
- 14.7 Any Goods returned to Trane which cannot be repaired and returned to the Buyer will belong to Trane and any replacement Goods will be guaranteed in accordance with Clause 14.2. Any repaired goods will be guaranteed for the remainder of the relevant warranty period granted at Clause 14.1.
- 14.8 In relation to Goods, all warranties, conditions and other terms implied by statute or common law (save for the conditions implied by section 12 of the Sale of Goods Act 1979) are, to the fullest extent permitted by law, excluded from the Contract.
- 14.9 In relation to the Services, Trane warrants that the Services will be provided using reasonable skill and care.
- 15. LIMITATION OF TRANE'S LIABILITY**
- 15.1 Subject to Clause 14, the following provisions set out the entire financial liability of Trane (including any liability for the acts or omissions of its employees, agents and sub-contractors) to the Buyer in respect of:
- 15.1.1 any breach of these Conditions; and
- 15.1.2 any representation, statement or tortious act or omission including negligence arising under or in connection with the Contract.
- 15.2 Nothing in these Conditions excludes or limits the liability of Trane for:
- 15.2.1 death or personal injury caused by Trane's negligence; or
- 15.2.2 for Trane's fraudulent misrepresentation.
- 15.3 Subject to conditions 14.8 and 15.2:
- 15.3.1 Trane's total liability in contract, tort (including negligence or breach of statutory duty), misrepresentation or otherwise, arising in connection with the performance or contemplated performance of this Contract shall be limited to £1,000,000; and
- 15.3.2 Trane shall not be liable to the Buyer for any indirect or consequential loss or damage (whether for loss of profit, loss of business, depletion of goodwill or otherwise), costs, expenses or other claims for consequential compensation whatsoever (howsoever caused) which arise out of or in connection with the Contract.
- 15.3.3 Subject to Trane's limited acceptance of liability for misrepresentations in Writing in accordance with Clause 15.3.1, Trane shall not be liable for any representations or statements made by Trane, its employees, agents or sub-contractors.
- 15.3.4 Trane shall have no liability to the Buyer for any loss, damage, costs, expenses or other claims for compensation arising from any instructions supplied by the Buyer whether in the Buyer's order or otherwise which are incomplete, incorrect, inaccurate, illegible or which arise from their late arrival or non-arrival, or any other fault of the Buyer.
- 16. TERMINATION**
- 16.1 Either party may terminate the Contract immediately:
- 16.1.1 by notice in Writing to the other if the other commits any material breach of these Conditions which is capable of remedy and fails to remedy the same within 30 days after being required by Written notice to do so (for the avoidance of doubt, late or non payment will be a material breach of condition); or
- 16.1.2 without notice if the other party has a bankruptcy order made against him or makes an arrangement or composition with his creditors, or otherwise takes the benefit of any Act for the time being in force for the relief of insolvent debtors, or (being a body corporate) convenes a meeting of creditors (whether formal or informal), or enters into liquidation (whether voluntary or compulsory) except a solvent voluntary liquidation for the purpose only of reconstruction or amalgamation, or has a receiver and/or manager, administrator or administrative receiver appointed of its undertaking or any part thereof, or a resolution is passed or a petition presented to any court for the winding up of the other party or for the granting of an administration order in respect of the other party, or any proceedings are commenced relating to the insolvency or possible insolvency of the other party or if the other party takes or suffers any similar or analogous action in any jurisdiction in consequence of debt.
- 16.2 Upon the termination of the Contract for any reason, subject to any rights or obligations which have accrued prior to termination (including the Buyer's obligation to pay), neither party shall have any further obligation to the other under the Contract.
- 16.3 In the event that before expiry of the fixed term the Buyer purports to terminate any maintenance element of the Contract then Trane shall be entitled to claim damages from the Buyer. In particular, but without prejudice to the generality of the foregoing, Trane may claim damages for loss of expected profit and expenditure incurred in expectation of fulfilling its obligations under the Contract.
- 17. APPLICABLE LAW**
- 17.1 This Contract shall be construed in all respects under English Law. Any dispute of difference arising under this Contract which is not settled in accordance with Clause 17.2 shall be subject to the exclusive jurisdiction of the English Courts.
- 17.2 If any dispute or difference arises out of or in connection with this Contract the parties will attempt to settle it by mediation in accordance with the Centre for Dispute Resolution ("CEDR") Model Mediation Procedure. Unless otherwise agreed between the parties, the mediator will be nominated by CEDR.
- 17.3 If either party fails or refuses to agree to or participate in the Alternative Dispute Jurisdiction procedure or, if in any event, the dispute or difference is not resolved to the satisfaction of both parties within 90 days after it has arisen the dispute or difference shall be referred to the Courts in accordance with Clause 17.1.
- 18. CONFIDENTIALITY**
- Both parties shall keep confidential and shall not without the prior consent in Writing of the other disclose to any third party any technical or commercial information which it has acquired from the other relating to the Goods/Services or the Contract.
- 19. FORCE MAJEURE**
- Trane reserves the right to defer the date of delivery/performance of the Services or to cancel the Contract or reduce the volume of the Goods ordered by the Buyer (without liability to the Buyer) if it is prevented from or delayed in the carrying on of its business due to circumstances beyond the reasonable control of Trane including, without limitation, acts of God, governmental actions, war or national emergency, riot, civil commotion, fire, explosion, flood, epidemic, lock-outs, strikes or other labour disputes (whether or not relating to either party's workforce), or restraints or delays affecting carriers or inability or delay in obtaining supplies of adequate or suitable materials Provided that, if the event in question continues for a continuous period in excess of 6 months, the Buyer shall be entitled to give notice in Hard Copy to Trane to terminate the Contract.
- 20. ASSIGNMENT**
- 20.1 The Buyer shall not be entitled to assign the Contract or any part of it without the prior written consent of Trane.
- 20.2 Trane may assign the Contract or any part of it to any person, firm or company.
- 21. NO THIRD PARTY**
- Pursuant to Section 1 (2) of the Contracts (Rights of Third Parties) Act 1999 ("the Act") the parties intend that no terms of these conditions may be enforced by a Third Party. For the purposes of this Clause "Third Party" shall have the meaning given in the Act.
- 22. GENERAL**
- 22.1 Each right or remedy of Trane under the Contract is without prejudice to any other right or remedy of Trane whether under the Contract or not.
- 22.2 If any provision of the Contract is found by any court, tribunal or administrative body of competent jurisdiction to be wholly or partly illegal, invalid, void, voidable, unenforceable or unreasonable it shall to the extent of such illegality, invalidity, voidness, voidability, unenforceability or unreasonableness be deemed severable and the remaining provisions of the Contract and the remainder of such provision shall continue in full force and effect.
- 22.3 Failure or delay by Trane in enforcing or partially enforcing any provision of the Contract will not be construed as a waiver of any of its rights under the Contract.
- 22.4 Any waiver by Trane of any breach of, or any default under, any provision of the Contract by the Buyer will not be deemed a waiver of any subsequent breach or default and will in no way affect the other terms of the Contract.
- 23. NOTICES**
- 23.1 Where stipulated in this Contract communications between the parties about this Contract must be in Writing.
- 23.2 Delivery, by hand or sent by pre-paid first class post, e-mail or sent by facsimile transmission shall be:
- 23.2.1 (in case of communications to Trane) to its registered office or such other address as shall be notified to the Buyer by Trane; or
- 23.2.2 (in the case of the communications to the Buyer) to the registered office of the addressee (if it is a company) or (in any other case) to the address of the Buyer set out in the Proposal which forms part of this Contract or such other address as shall be notified to Trane by the Buyer.
- 23.3 Communications shall be deemed to have been received:
- 23.3.1 if sent by pre-paid first class post, 2 days (excluding Saturdays, Sundays and bank and public holidays) after posting (exclusive of the day of posting);
- 23.3.2 if delivered by hand, on the day of delivery;
- 23.3.3 if sent, by facsimile transmission or electronic mail and provided sent to the correct number or email address of the addressee (with correct transmission confirmed), on a working day prior to 4.00 pm, at the time of transmission and otherwise on the next working day.