Date
20.07.2023

52 Avenue Road

Ventilation Services – Planning Design Report

Document status

Project No 723	Project 52 Avenue Road	Client 52 Avenue Road Limited London	In conjunction with: DOMVS London Studio 86, Switch House East Battersea Power Station London SW11 8BB	
Revision	Date	Status	Prepared by	Checked by
—	20.07.2023	Planing condition 6 discharge	Mazda Rustomji	Bojan Cekic

VENTILATION

Townhouses Ventilation Systems

Each townhouse will be mechanically ventilated via 4No. wall mounted residential high efficiency mechanical ventilation heat recovery (MVHR) units. Fresh air supply ductwork will distribute from the MVHR units to supply to all the habitable rooms and extract ductwork will provide extract to all the toilets and kitchens. All MVHR will be supplied with electrical heating coils. Individual MVHR controls will be linked to townhouse BMS or AV system to monitor for MVHR fault signals. Fresh air will be supplied and extracted from different areas via number of linear diffusers and/or ventilation valves (this will be coordinated with the architect and interior designer at next design stage)



Figure 4: Example horizontal MVHR unit , linear supply/extract diffuser and disc valve

Intake and exhaust ductwork will extend to external air bricks or louvres on facades or roof cowls. Ductwork connections to the façade will be fire rated and insulated to comply with Building Regulations. Attenuation will be provided to all duct connections to and from the MVHR unit.

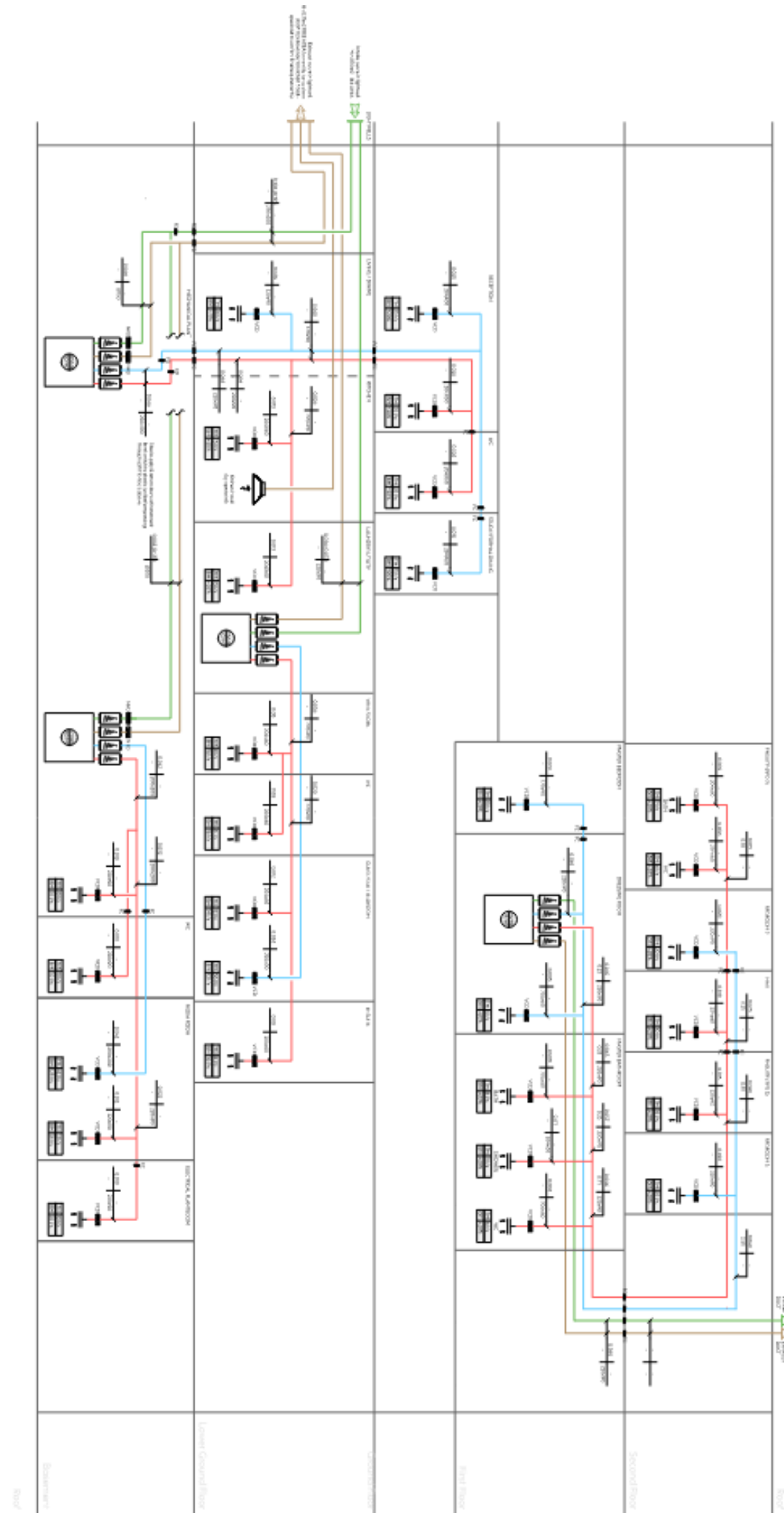

Figure 5: Example of fire rated ductwork connections to facade for residential intake & exhaust ventilation and supply/exhaust louvre

All MVHR units will operate on a trickle and boost principle. Each unit will operate via packaged controls to switch from trickle to boost on activation of a light switch in any of the wet rooms served, or on sensing high humidity in the extract ductwork.

Residential kitchen ventilation will be via a dedicated extract hood above the hob (specified by others). Ductwork will extend from the hood and connect to a dedicated exhaust louvre on the façade.

Purge ventilation compliance (Building Regulations Part F) and overheating compliance (Building Regulations O) shall be achieved via openable windows in habitable areas where windows are available. In all habitable rooms where there are no external windows/doors available purge ventilation will be provided via MVHR units. Where purge ventilation is provided by MVHR units a ventilation rate of minimum 4 air changes per hour will be achieved as per Building Regulations part F requirements.



Amenity Areas Ventilation Systems

Landlord basement amenity areas will be mechanically ventilated via 4No. commercial high efficiency mechanical ventilation heat recovery (MVHR) units.

Fresh air supply and extract ductwork will distribute from the MVHR units (as indicated on ventilation drawings) to supply all amenity areas including gym, yoga studio, meeting and lounge areas, kitchenette, toilets and changing areas, staff back of house areas.

All MVHR will be supplied with LTHW or electrical heating coils and individual controls.

Fresh air will be introduced to all areas via number of linear diffusers and/or ventilation valves (this will be coordinated with the architect and interior designer at next design stage).

Thermal insulation will be applied to intake and exhaust ductwork

MVHR units serving landlord areas will operate on a CO2 and presence detector controls and will interface with the BMS for run / fault status.



Figure 7: Example commercial horizontal MVHR unit with heat recovery, supply/extract diffuser and disc valve

Intake and exhaust ductwork will run to connect to external air supply and exhaust turrets or façade incorporated louvres. Supply and exhaust ductwork will be insulated to prevent condensation on ductwork surface. Attenuation will be provided to all duct connections to and from the MVHR unit.



Bin & Cycle Storage Ventilation Systems

Bin store and cycle store on ground floor shall be naturally ventilated via louvres in the façade of each side of the bin and cycle store.

Concierge house located on the ground floor next to main gate will be naturally ventilated via louvres in the façade.

Plant Room Ventilation Systems

Basement and lower ground plant rooms shall be mechanically ventilated via dedicated MVHR unit located in basement plant room. Fresh air supply and exhaust to/from MVHR unit will be provided from air supply and exhaust turrets at ground floor level.

