

W-016 - PVC D/G  
Existing Section B  
Scale 1/10

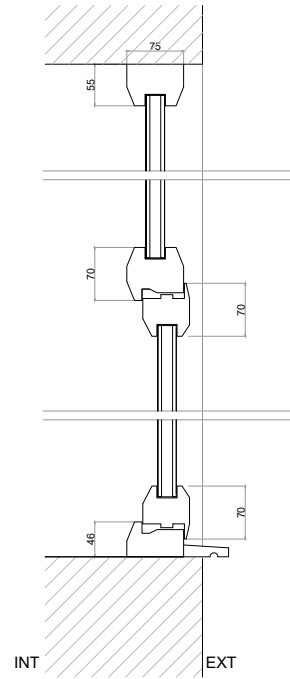

W-016 - PVC D/G  
Existing Section A  
Scale 1/10

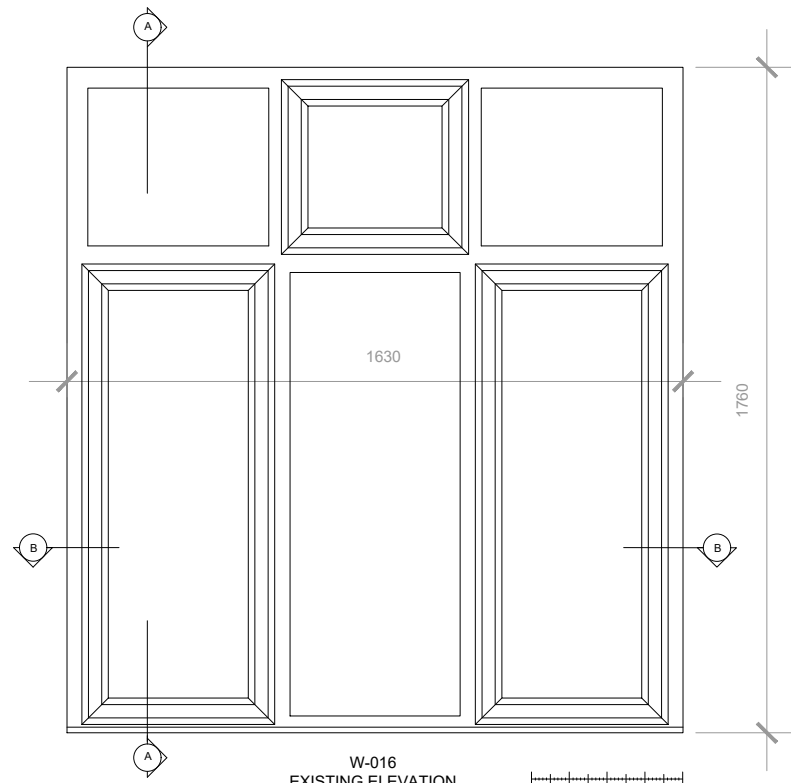
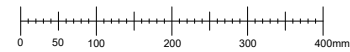

W-016  
EXISTING ELEVATION  
Scale 1/20

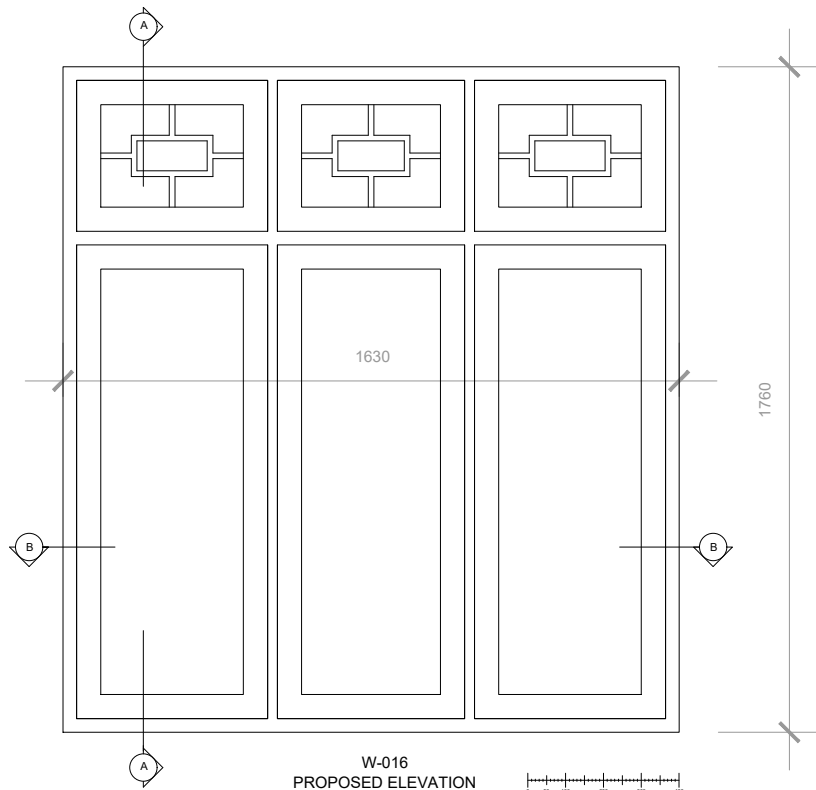

W-016  
PROPOSED ELEVATION  
Scale 1/20

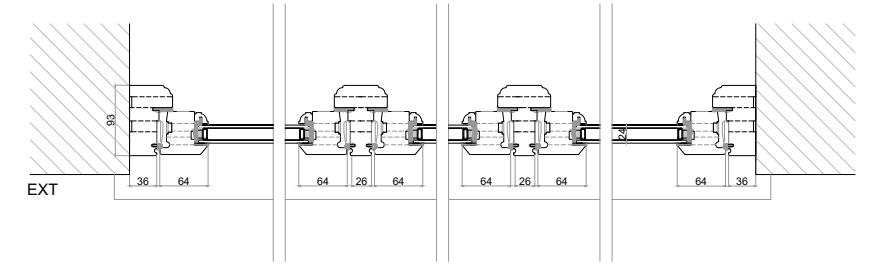

W-016 - Timber D/G  
Proposed Section B  
Scale 1/10

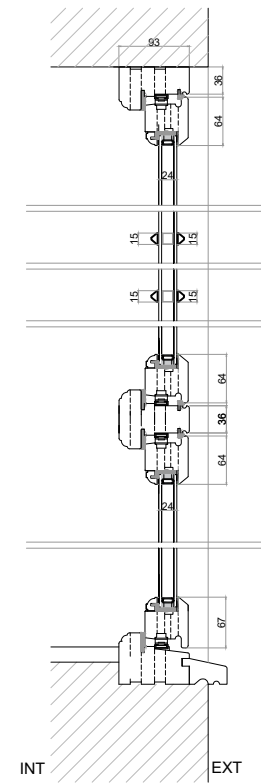

W-016 - Timber D/G  
Proposed Section A  
Scale 1/10



WINDOW 016

Address:

176 Goldhurst Terrace,  
London NW6 3HN

DWG no: W-016

SCALE:  
1/10 & 1/20

DATE:  
15/07/2023

SHEET: A3

REV: -

This drawing is copyright © and may not be reproduced without permission  
All measurements are taken using laser measure and therefore, may be subject to a small margin of error.  
Plans not suitable for construction purposes

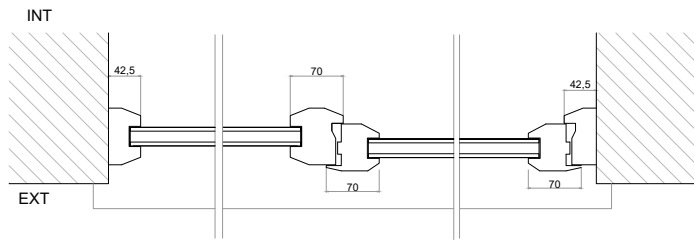

W-017 - PVC D/G  
Existing Section B  
Scale 1/10

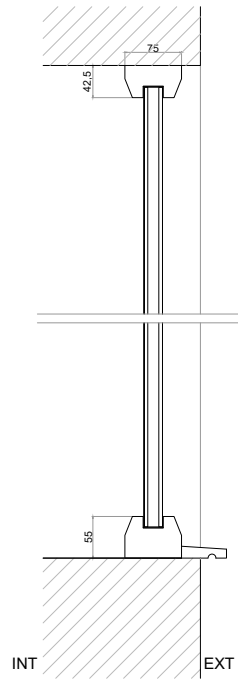

W-017 - PVC D/G  
Existing Section A  
Scale 1/10

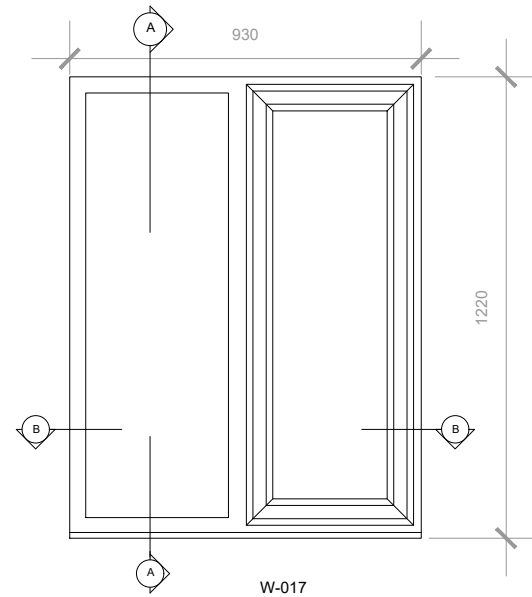
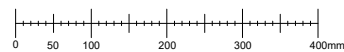

W-017  
EXISTING ELEVATION  
Scale 1/20

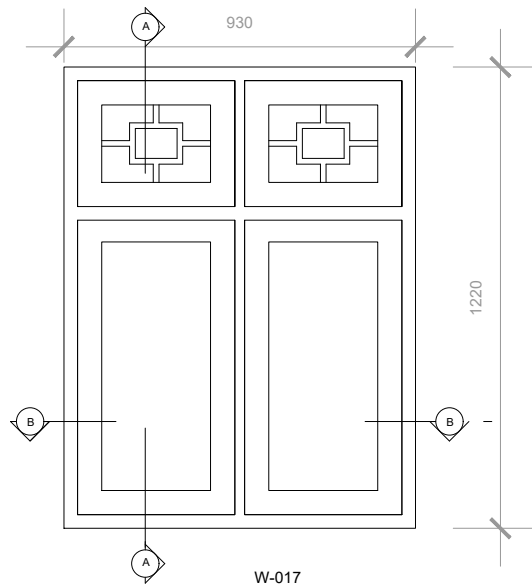
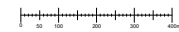

W-017  
PROPOSED ELEVATION  
Scale 1/20

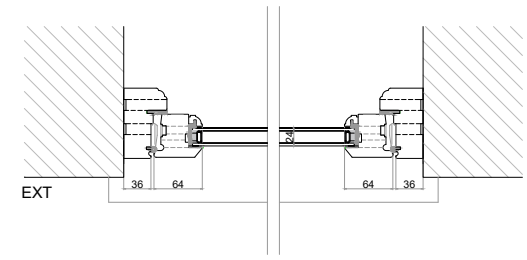

W-017 - Timber D/G  
Proposed Section B  
Scale 1/10

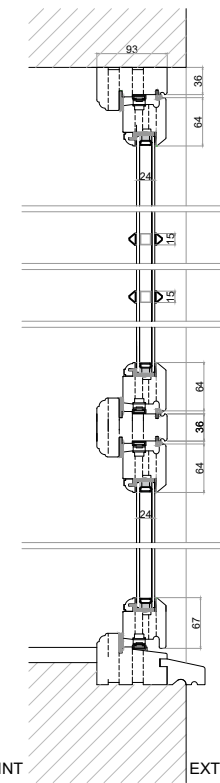

W-017 - Timber D/G  
Proposed Section A  
Scale 1/10



WINDOW 017

Address:

176 Goldhurst Terrace,  
London NW6 3HN

DWG no: W-017

SCALE:  
1/10 & 1/20

DATE:  
18/07/2023

SHEET: A3

REV: A

This drawing is copyright © and may not be reproduced without permission  
All measurements are taken using laser measure and therefore, may be subject to a small margin of error.  
Plans not suitable for construction purposes

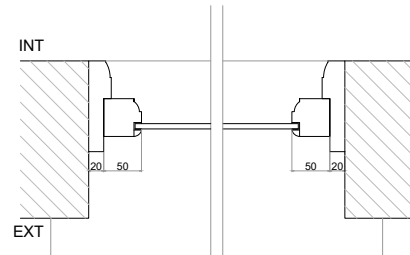

W-018 - Timber S/G  
Existing Section B  
Scale 1/10

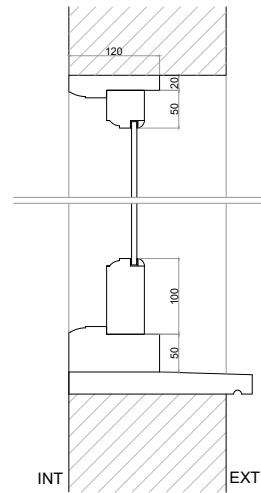

W-018 - Timber S/G  
Existing Section A  
Scale 1/10

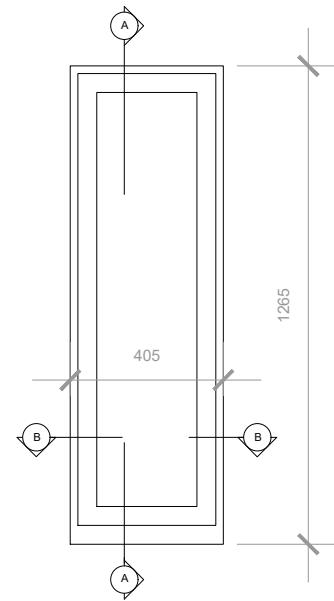

W-018  
EXISTING ELEVATION  
Scale 1/20

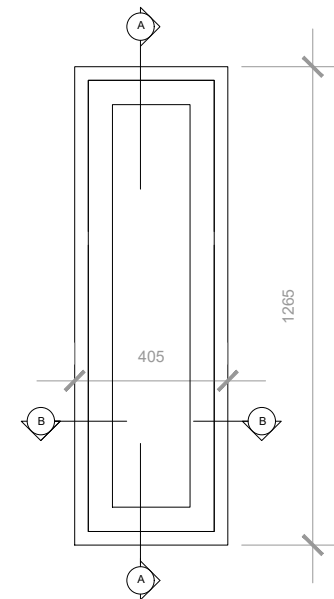

W-018  
PROPOSED ELEVATION  
Scale 1/20

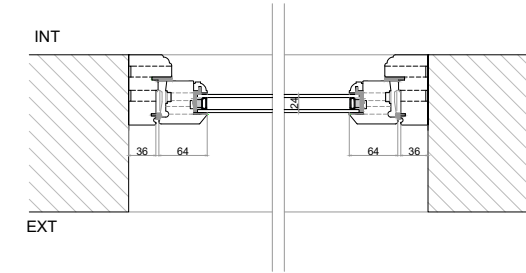
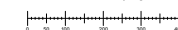

W-018 - Timber D/G  
Proposed Section B  
Scale 1/10

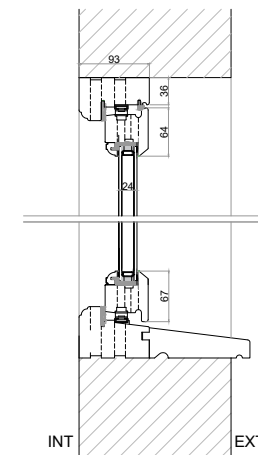

W-018 - Timber D/G  
Proposed Section A  
Scale 1/10

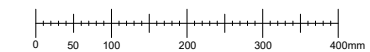

WINDOW 018

Address:

176 Goldhurst Terrace,  
London NW6 3HN

DWG no: W-018

SCALE:  
1/10 & 1/20

DATE:  
18/07/2023

SHEET: A3

REV: A

This drawing is copyright © and may not be reproduced without permission  
All measurements are taken using laser measure and therefore, may be subject to a small margin of error.  
Plans not suitable for construction purposes

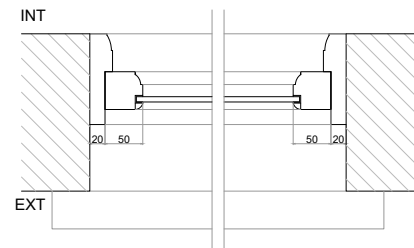

W-019 - Timber S/G  
Existing Section B  
Scale 1/10

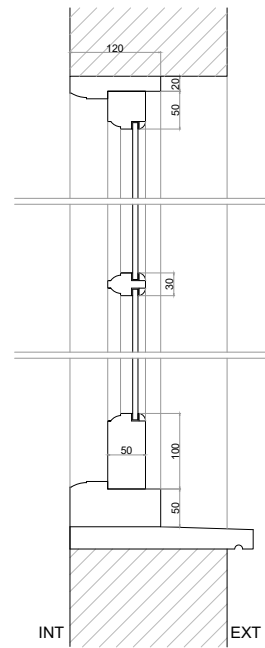
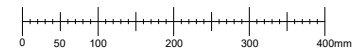

W-019 - Timber S/G  
Existing Section A  
Scale 1/10

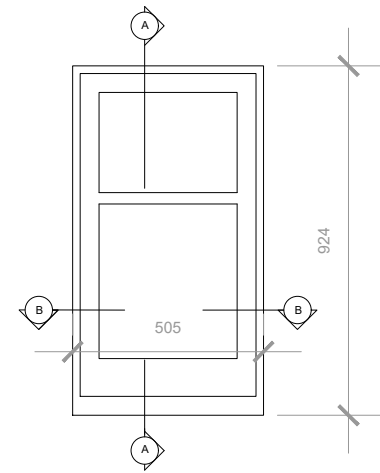

W-019  
EXISTING ELEVATION  
Scale 1/20

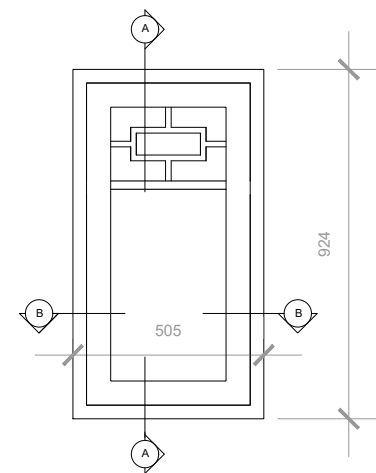

W-019  
PROPOSED ELEVATION  
Scale 1/20

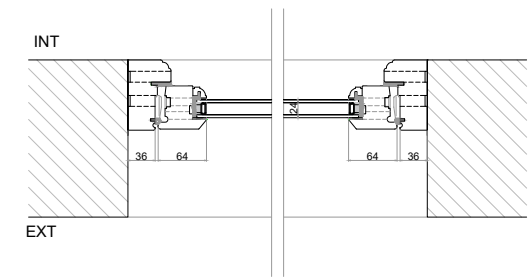
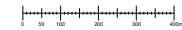

W-019 - Timber D/G  
Proposed Section B  
Scale 1/10

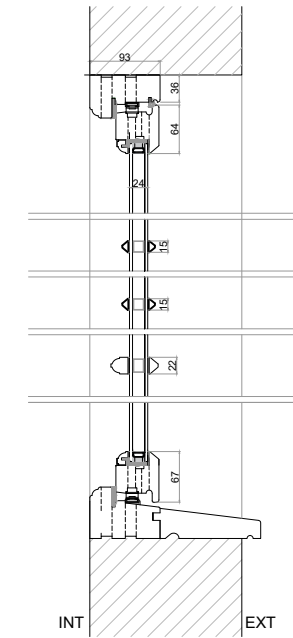

W-019 - Timber D/G  
Proposed Section A  
Scale 1/10

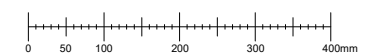

WINDOW 019

Address:

176 Goldhurst Terrace,  
London NW6 3HN

DWG no: W-019

SCALE:  
1/10 & 1/20

DATE:  
18/07/2023

SHEET: A3

REV: A

This drawing is copyright © and may not be reproduced without permission  
All measurements are taken using laser measure and therefore, may be subject to a small margin of error.  
Plans not suitable for construction purposes

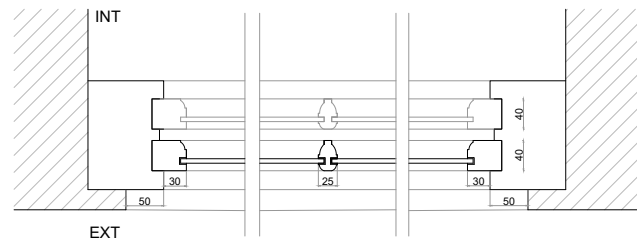

W-020-Timber S/G  
Existing Section B  
Scale 1/10

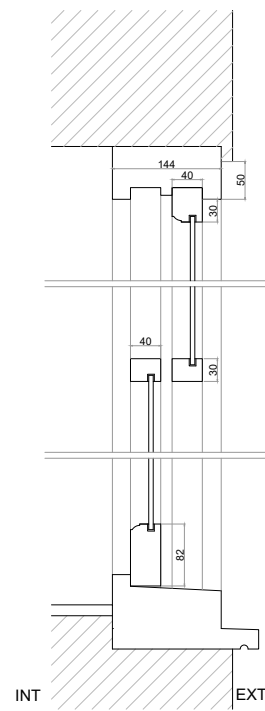
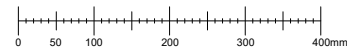

W-020 - Timber S/G  
Existing Section A  
Scale 1/10

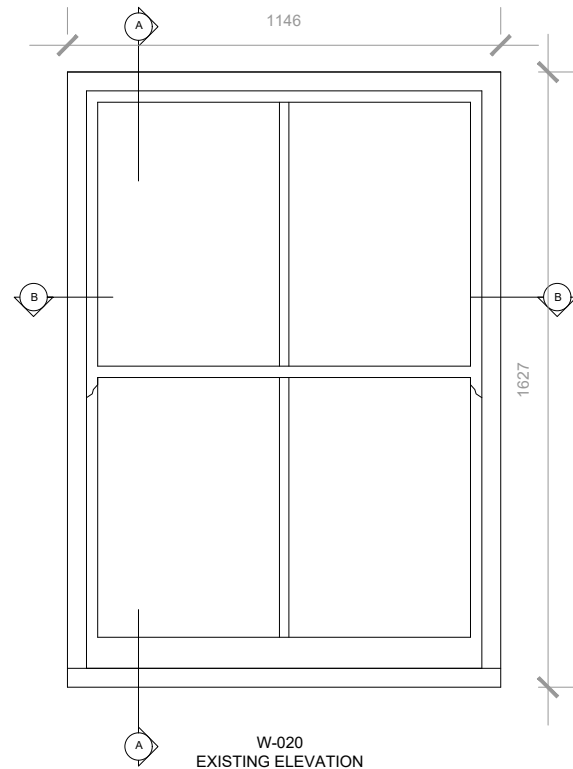
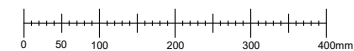

W-020  
EXISTING ELEVATION  
Scale 1/20

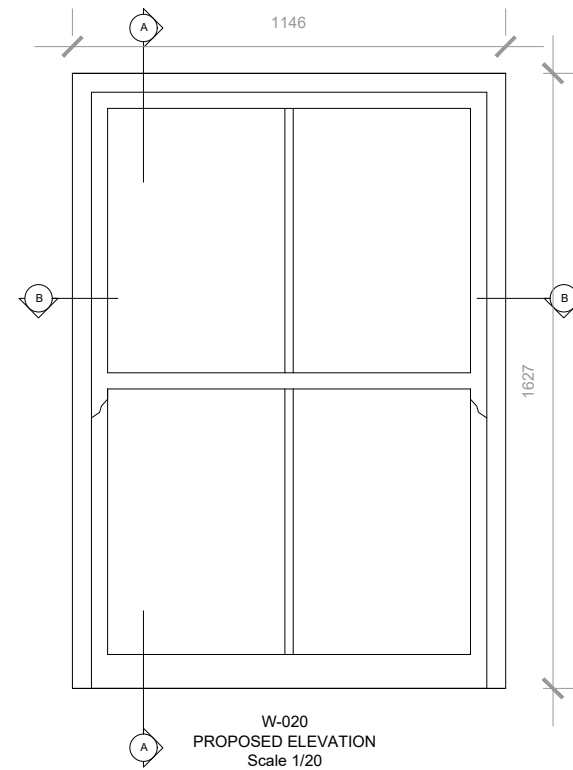

W-020  
PROPOSED ELEVATION  
Scale 1/20

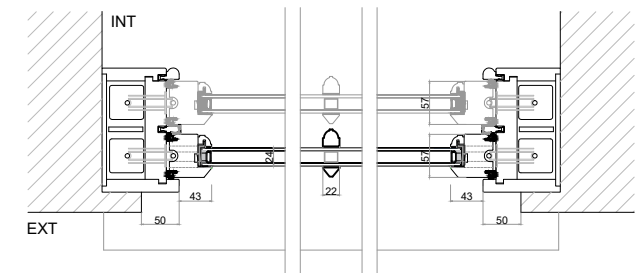
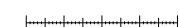

W-020-Timber D/G  
Proposed Section B  
Scale 1/10

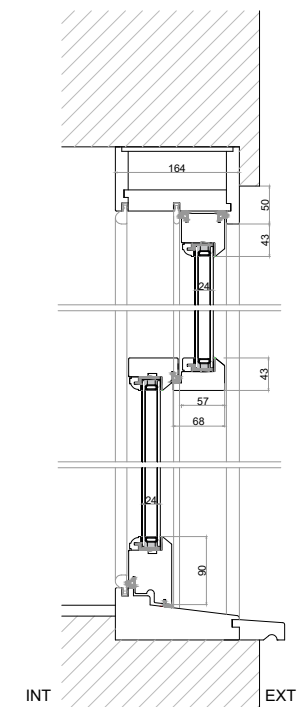

W-020 - Timber D/G  
Proposed Section A  
Scale 1/10



WINDOW 020

Address:

176 Goldhurst Terrace,  
London NW6 3HN

DWG no: W-020

SCALE:  
1/10 & 1/20

DATE:  
15/07/2023

SHEET: A3

REV: -

This drawing is copyright © and may not be reproduced without permission  
All measurements are taken using laser measure and therefore, may be subject to a small margin of error.  
Plans not suitable for construction purposes

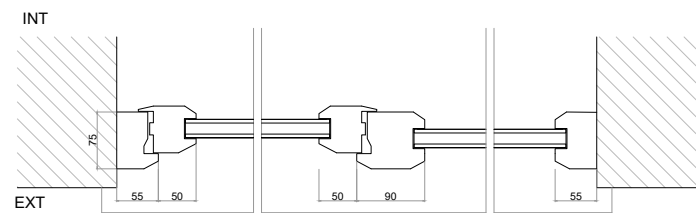

W-021 - PVC D/G  
Existing Section B  
Scale 1/10

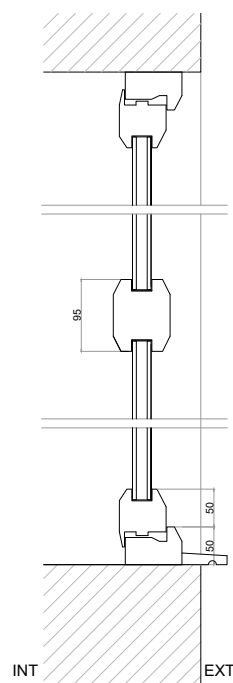
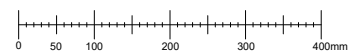

W-021- PVC D/G  
Existing Section A  
Scale 1/10

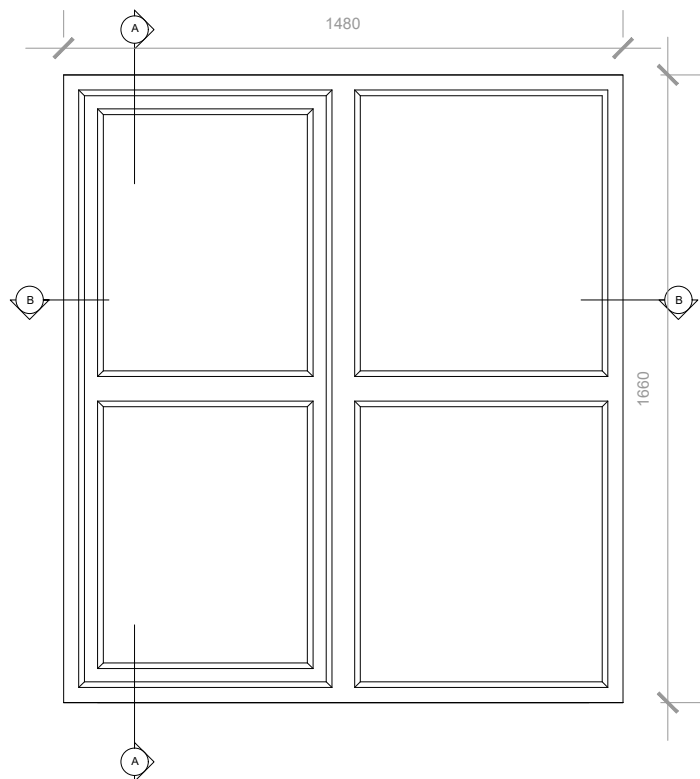
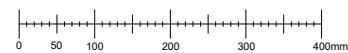

W-021  
EXISTING ELEVATION  
Scale 1/20

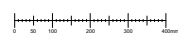
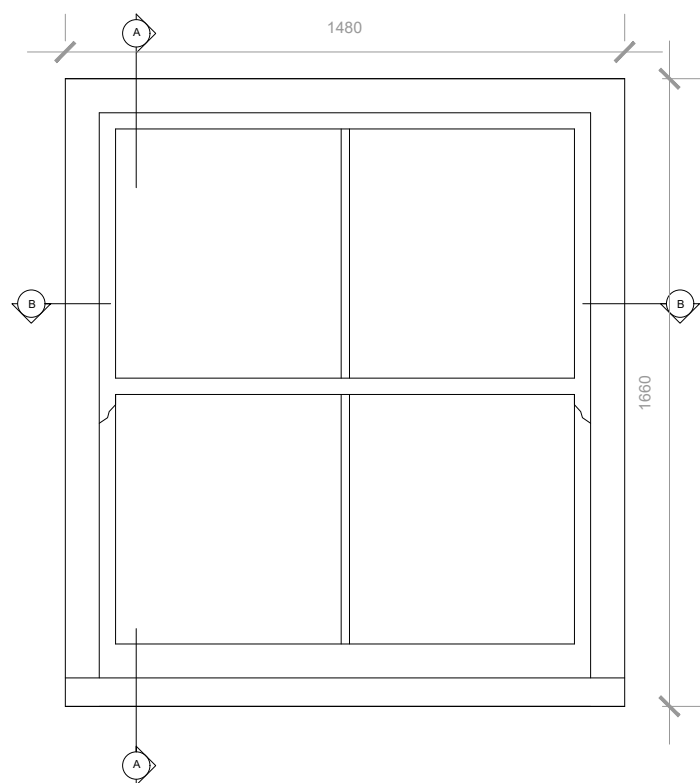

W-021  
PROPOSED ELEVATION  
Scale 1/20

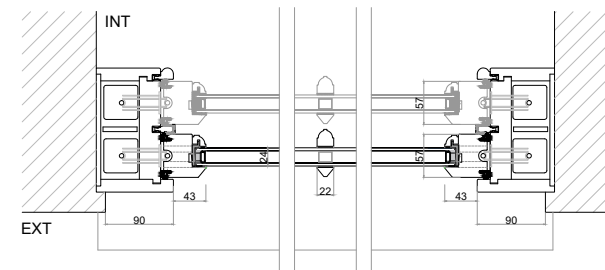

W-021-Timber D/G  
Proposed Section B  
Scale 1/10

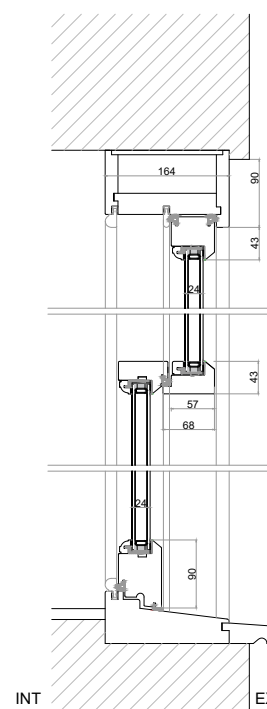

W-021 - Timber D/G  
Proposed Section A  
Scale 1/10

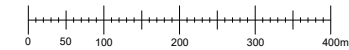

WINDOW 021

Address:

176 Goldhurst Terrace,  
London NW6 3HN

DWG no: W-021

SCALE:  
1/10 & 1/20

DATE:  
15/07/2023

SHEET: A3

REV: -

This drawing is copyright © and may not be reproduced without permission  
All measurements are taken using laser measure and therefore, may be subject to a small margin of error.  
Plans not suitable for construction purposes