

Produced In Relation to Planning Application for Camden Council.



## **DESIGN AND ACCESS STATEMENT.**

### **Address: 46 Lambs Conduit Street, London WC1N 3LB – Planning Application for Replacement Shopfront & New Projecting Sign – July 2023**

#### **Introduction:**

This report is formulated to support the above Planning Application for the provision of a replacement timber shopfront and new projecting illuminated bus-stop sign at 46 Lambs Conduit Street, London, WC1N 3LB.

The objective for the application will be to replace the existing stained timber shopfront which is a historic previous tenant installation that is not considered in keeping with the remainder of the units in 40-46 Lambs Conduit Street which fall in the freehold ownership of GMS Estates Limited.

The replacement shopfront is intended to match the adjacent units in such a way as to compliment and balance the appearance or ambiance of the above property whilst not affecting the aesthetic appearance of the subject and surrounding properties.

The property is located on the edge of the Bloomsbury Conservation Area although the proposals are not considered to be detrimental to the surrounding units, with the replacement considered to be complimentary.

#### **Use:**

The Application site is understood to have been built circa 1955 and is formed of a purpose-built mixed-use offices and retail shops known as Rapier House, with four separate retail shop units to the ground floor and basement levels at 40-46 Lambs Conduit Street with three floors of office accommodation over. The property is set within an area of mixed style and use buildings within the Bloomsbury area of Holborn. The proposed alterations will not alter or change the subject buildings existing use.



**Front Elevation.**



**Location Plan.**

**Layout:**

The existing shops and offices configuration of the above property at Rapier House 40-46 Lambs Conduit Street will generally remain unaltered by the proposed application, but the shopfront and layout at 46 Lambs Conduit Street is proposed to be revised where this currently differs in the form of the entrance door location and design of the shopfront from the other three adjacent shop units.

Numbers 40, 42 and 44 Lambs Conduit Street are all provided with either single or double doors set to either the far right or left of the units, with the remainder of the shopfront presented in a single large, glazed format shopfront with a transom light above the door only. A small shallow timber panelled stall riser is also provided to each of these shopfronts.

However, number 46 Lambs Conduit Street has a panelled shopfront with a single central door and a pair of glazed windows to each side, with raised panelled full height decorative panels and matching stall risers together with a large solid timber infill panel above the entire shopfront width. This presents a substantial alteration in appearance of this building compared to the adjacent three shop units.

The proposed alteration is considered to substantially improve the layout and aesthetic balance of the shops and overall building.

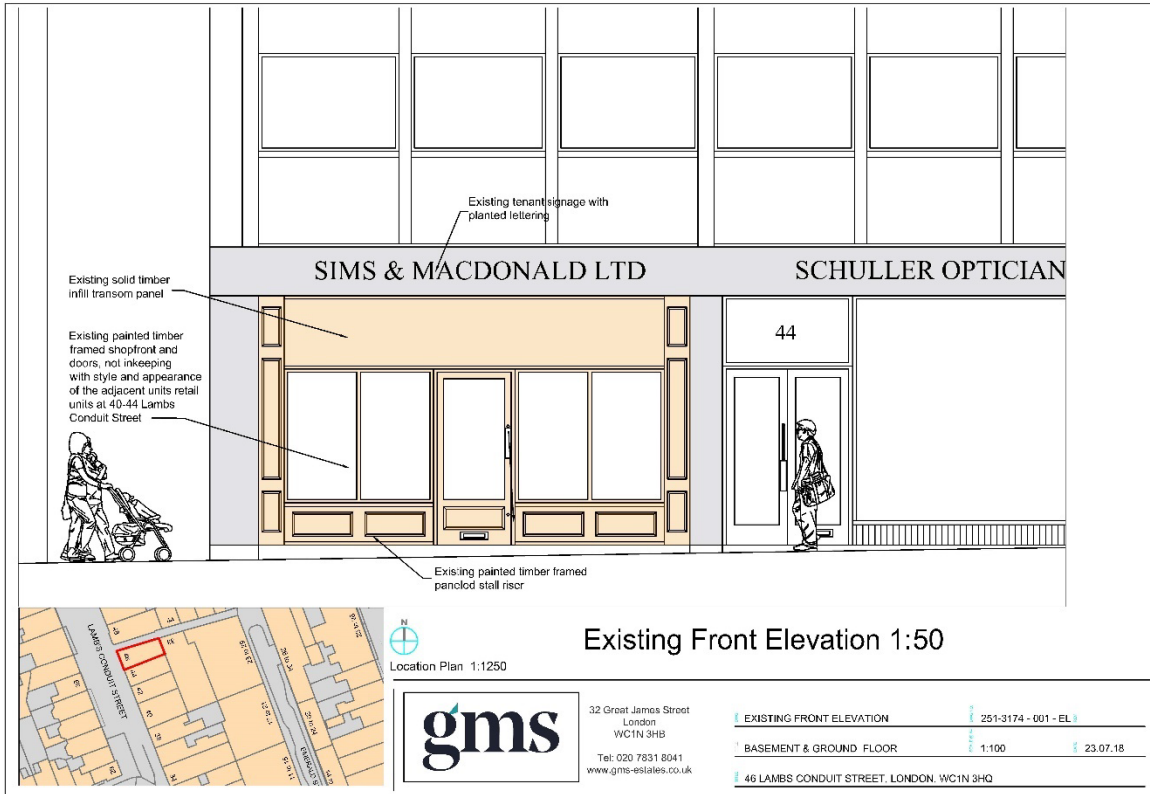

Existing Elevation/Shopfront:

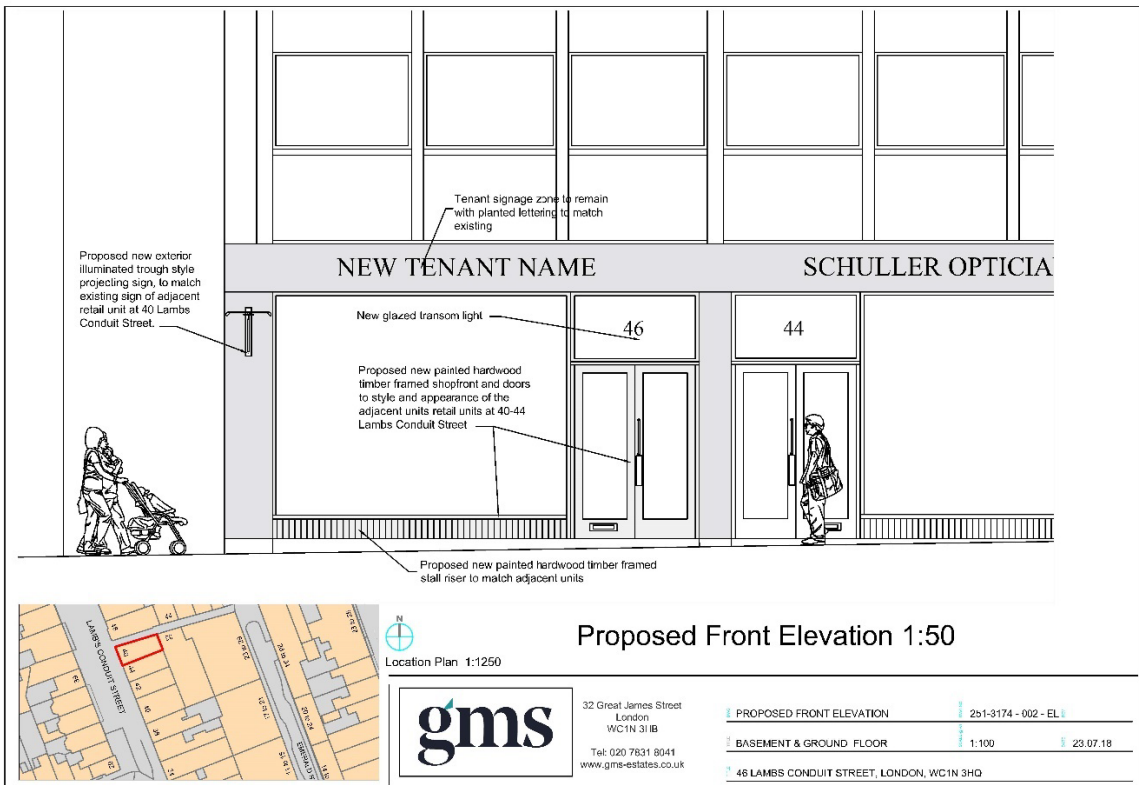

Proposed Elevation/Shopfront:

## **Scale:**

The proposals are not considered to have any material effect on the scale of the building and will remain within the confines of the existing building footprint and sympathetic in respect of their height, width, and length.

## **Landscape:**

There is no significant landscape works proposed for the alterations or any landscape changes in respect of this application.

## **Appearance:**

The choice in design, appearance and location of the revised shopfront is intended to be sympathetic to the existing building and to have minimal impact on the surrounding properties, in a similar fashion to other similar installations noted to the direct adjacent properties.

There is no proposed change in the external materials of the building with the proposed shopfront to be hardwood timber framed and single glazed, with the final decorative colour/finish to be chosen by the incoming tenants. The existing painted rendered columns to either side of the shopfront and upper façade of Rapier House will remain unchanged.

The planning application also includes for the installation of a new illuminated trough lit projecting bus-stop sign, to match in design and appearance to that already installed to 42 Lambs Conduit Street.

The design matches that seen in the photos and drawing below:



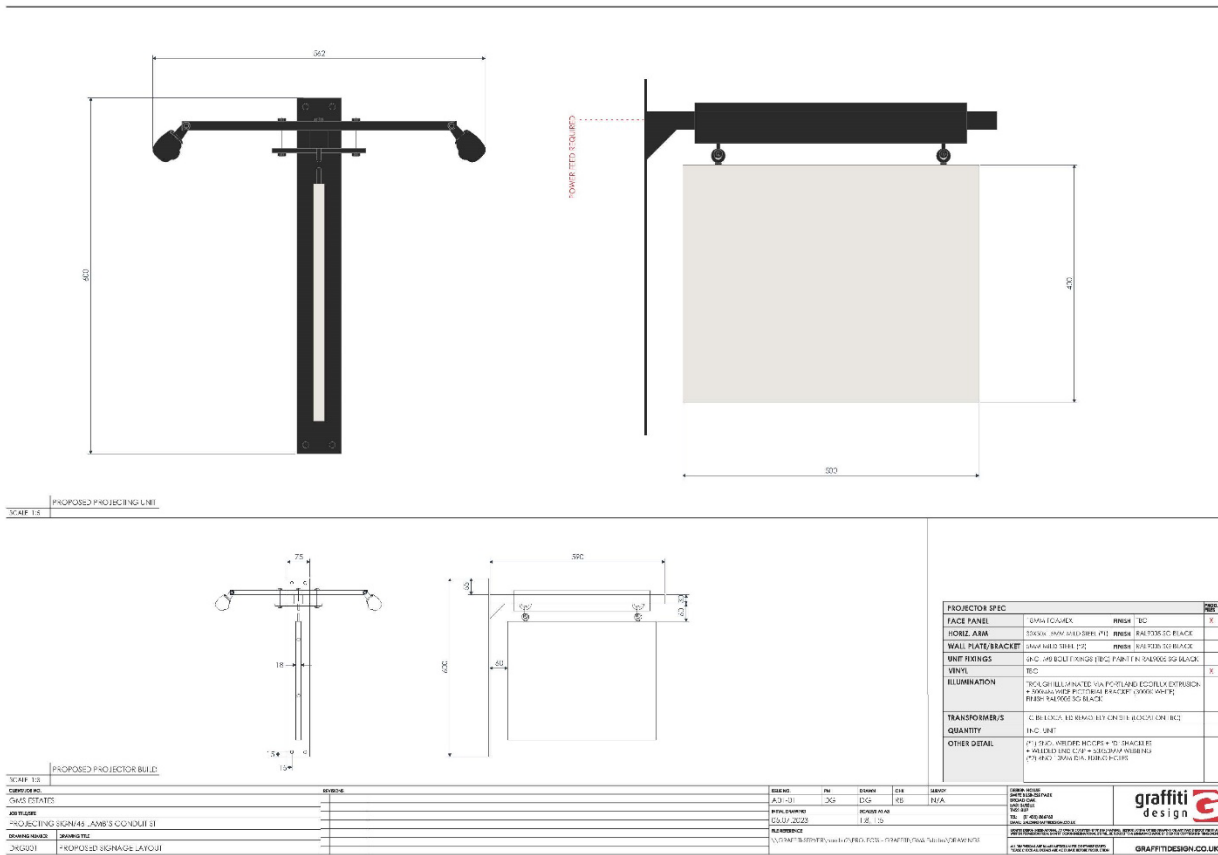

Therefore, advertisement consent is also sought as part of this application.

### Access:

The proposed works do not involve any alteration to either pedestrian or to existing vehicular access provided to the property.

### Conclusions:

The proposed Planning Application is considered to a sympathetic and aesthetically pleasing revised shopfront to the vacant retail shop unit at 46 Lambs Conduit Street, and in in-keeping with the remainder of the building parade and provides a better balance to the building without having any detrimental impact on the buildings existing vernacular.



The replacement shopfront construction proposes to use traditional materials typical for its type and age, with no substantive material alterations proposed.

Please do not hesitate to contact us if you need any further information.

A handwritten signature in black ink, consisting of several overlapping loops and lines, positioned over the contact information.

Robert Chisnall BSc MRICS  
Estates Building Surveyor  
GMS Estates Limited  
32 Great James Street  
London WC1N 3HB

Tel: (020) 7831 8041

Fax: (020) 7405 1629

Direct Dial: (0207) 438 1272

Mailto: [rc@gms-estates.co.uk](mailto:rc@gms-estates.co.uk)

Web: [www.gms-estates.co.uk](http://www.gms-estates.co.uk)