

THIS DRAWING IS © JOYCE & REDDINGTON HOLDINGS LTD AND MUST NOT BE USED, RETAINED, DISCLOSED TO THIRD PARTIES OR REPRODUCED (EITHER ELECTRONICALLY OR MECHANICALLY) WITHOUT WRITTEN AUTHORITY FROM THE AUTHORIZING COMPANY.

PLEASE USE ONLY STATED DIMENSIONS ONLY. DO NOT SCALE FROM THIS DRAWING. ALL GEOMETRY CONTAINED WITHIN IS FOR INFORMATION PURPOSES ONLY AND ALL DIMENSIONS MUST BE CHECKED ON-SITE PRIOR TO ANY MANUFACTURE. PLEASE READ THIS DRAWING IN CONJUNCTION WITH OTHER RELEVANT DESIGN & SPECIFICATION DRAWINGS PLUS ALL RELEVANT SECTIONS OF THE SPECIFICATIONS. PLEASE CONFIRM THAT THIS IS THE LATEST VERSION OF THE DRAWING BY READING IT IN CONJUNCTION WITH THE RELEVANT DRAWING ISSUE SHEET.

IF YOU HAVE RECEIVED THIS AS A DWG FILE RATHER THAN A PDF, THE CTB FILE NAME/CTB MUST BE USED IN ORDER FOR THIS DRAWING TO BE PLOTTED AS INTENDED.

ANY ERRORS OR DIVERGENCES SHOULD BE BROUGHT TO THE ATTENTION OF THE DESIGNER IMMEDIATELY.

JOYCE & REDDINGTON HOLDINGS LIMITED SHALL HAVE NO RESPONSIBILITY FOR ANY USE MADE OF THIS DRAWING OTHER THAN THAT WHICH IT WAS PREPARED & ISSUED.

DISCLAIMER: PLEASE KEEP IN MIND THAT THE VENEERS WE OFFER ARE, IN FACT, REAL WOOD AS SUCH THE VENEERED PRODUCTS YOU SPECIFY MAY FEATURE THE GRAIN VARIATION AND NATURAL CHARACTERISTICS ALLOWED IN THE GRADE AND SPECIES SPECIFIED.

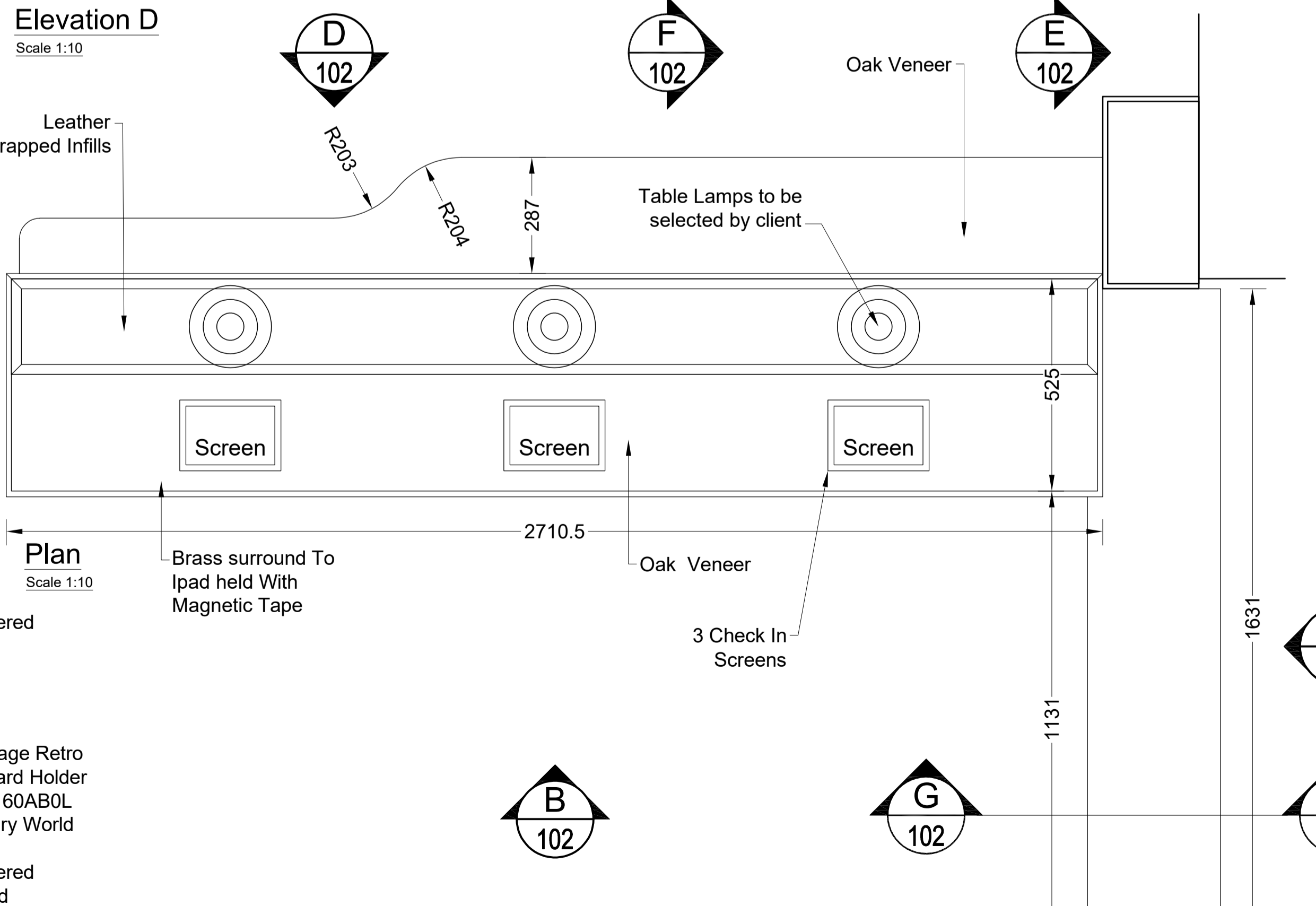
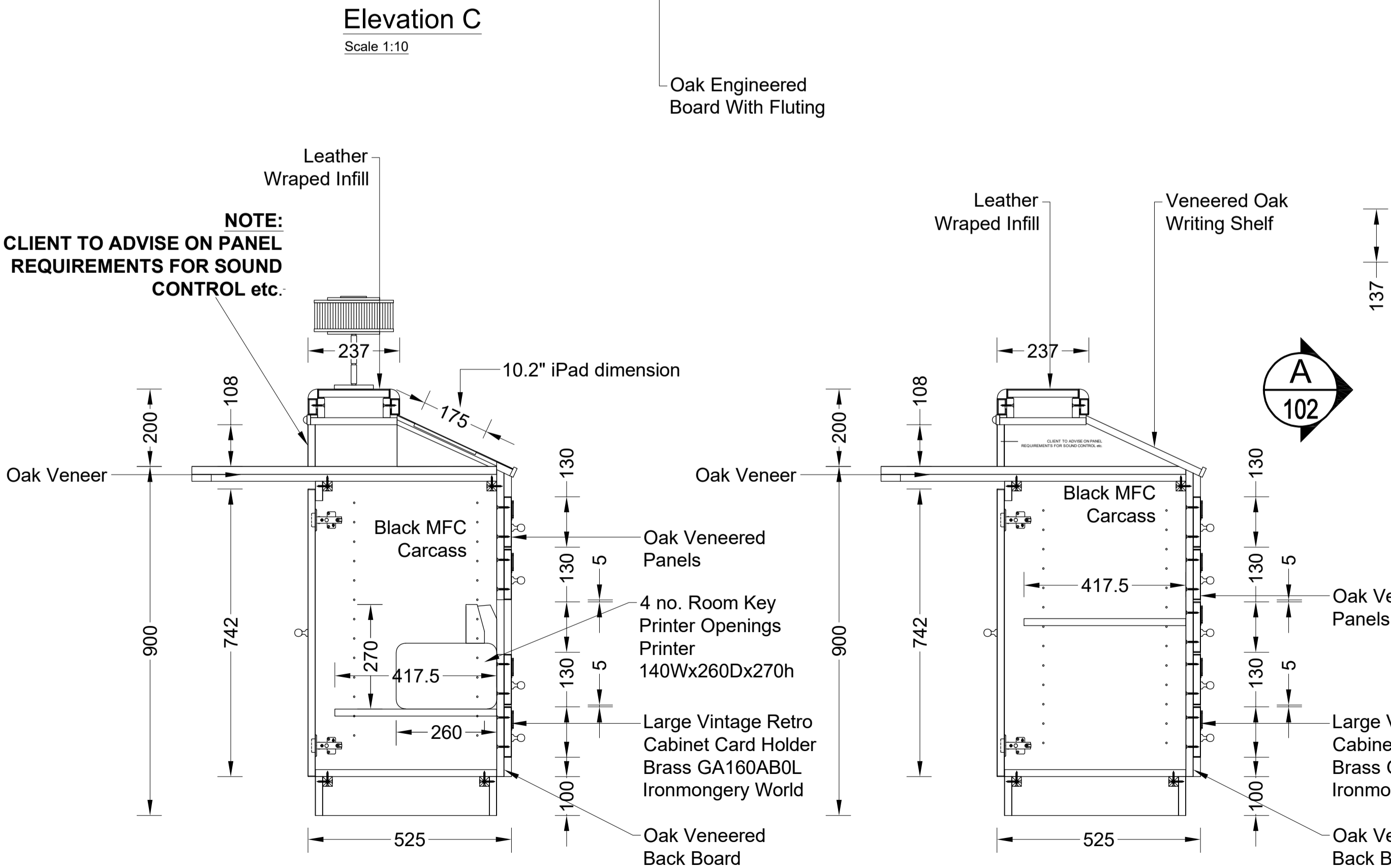
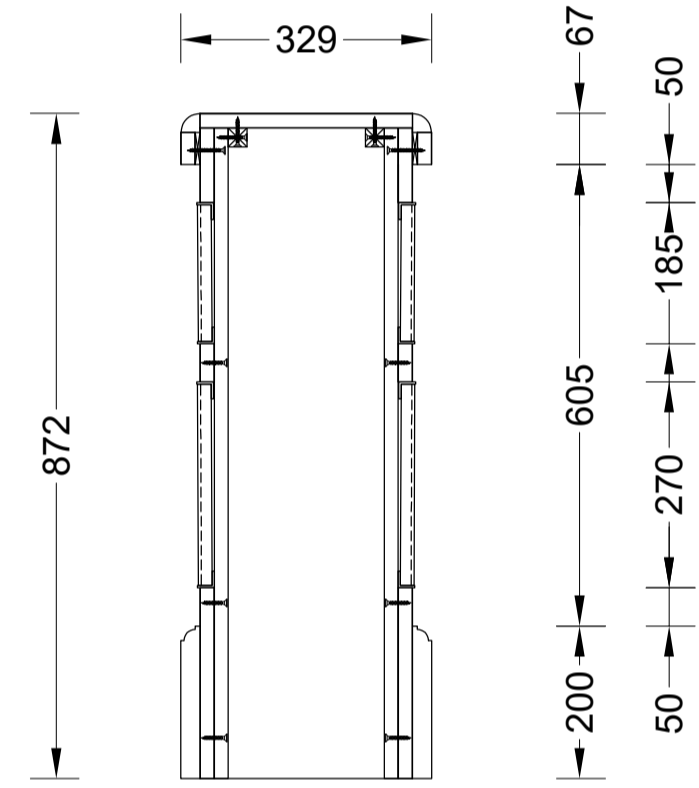
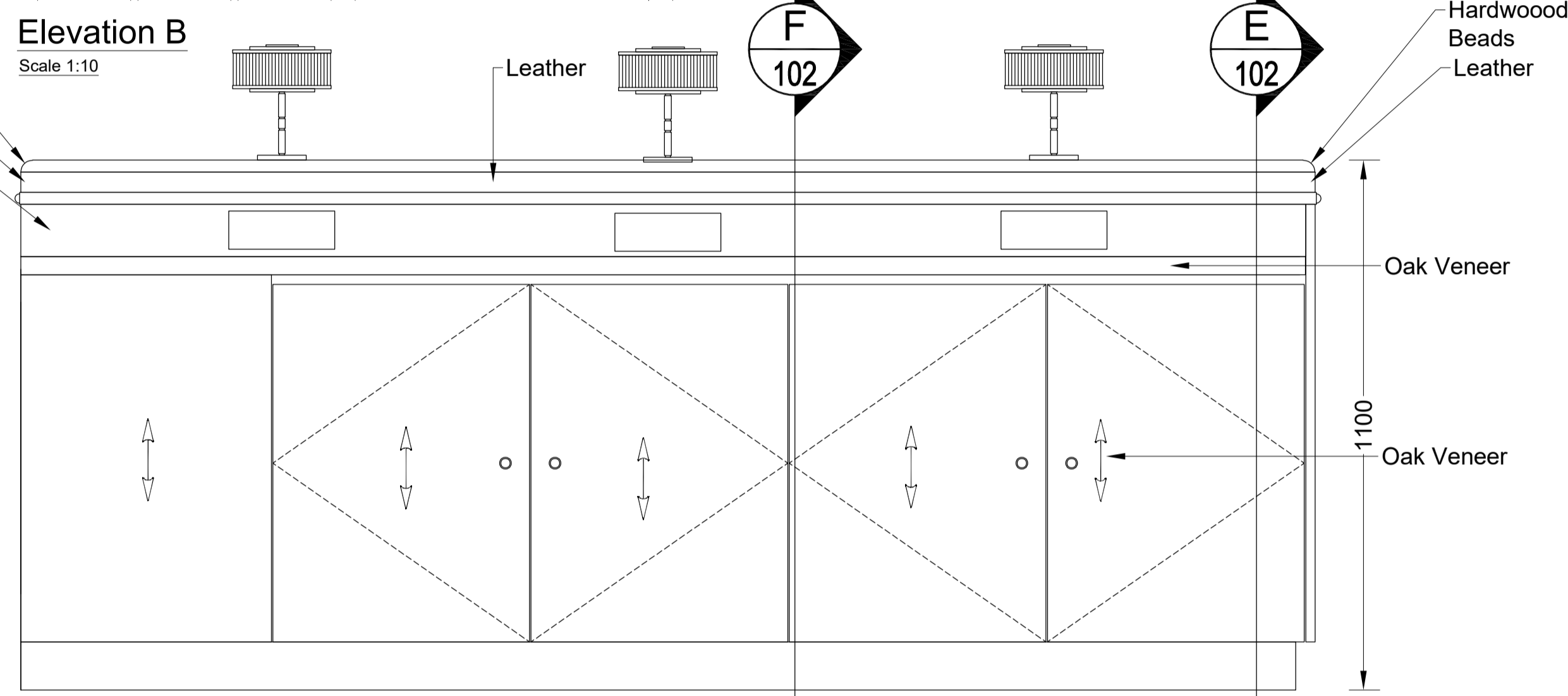
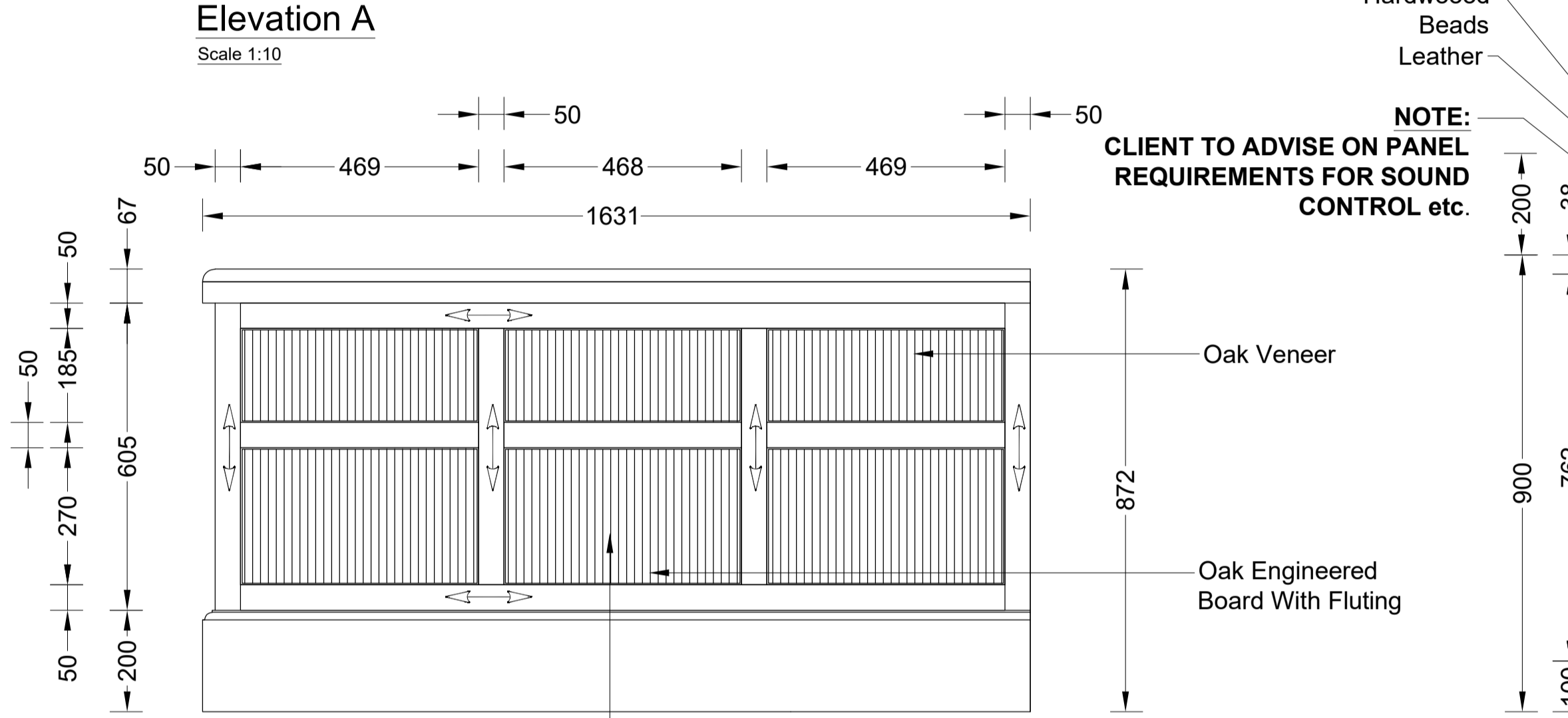
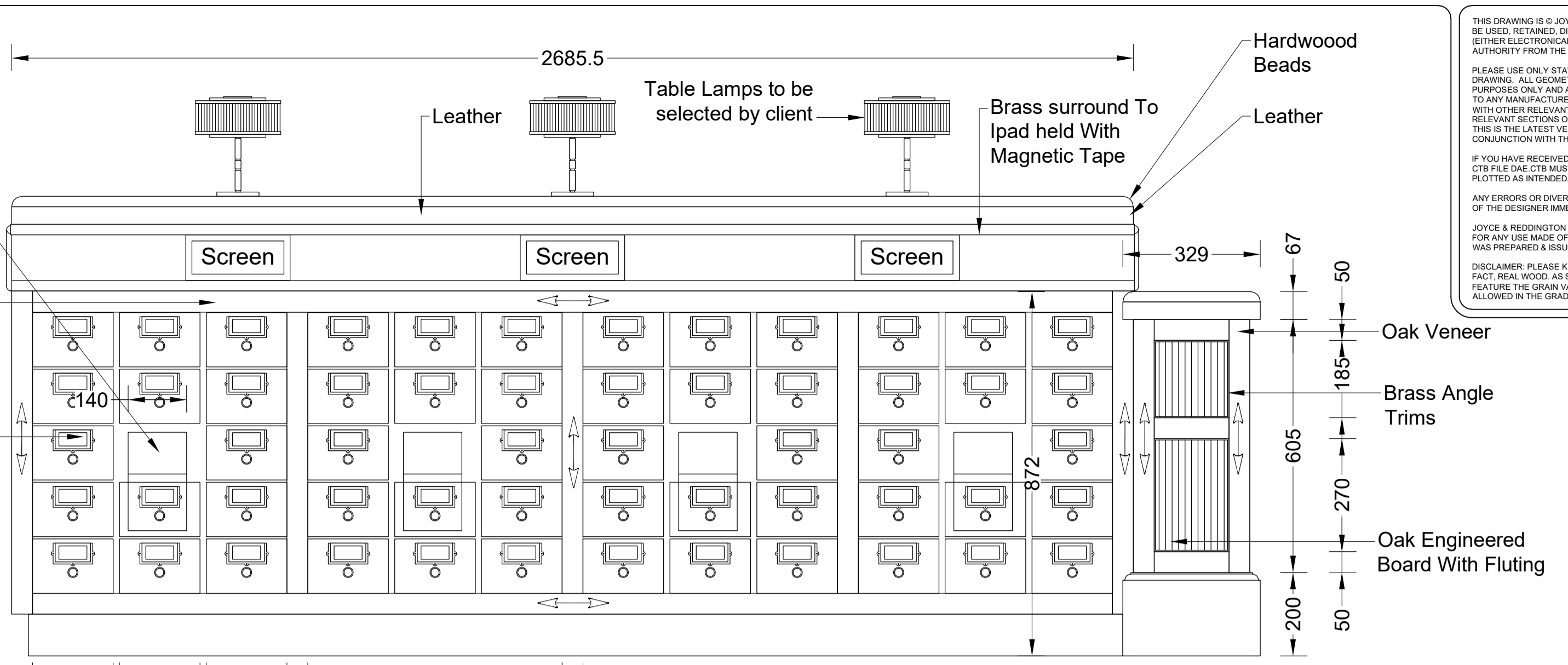
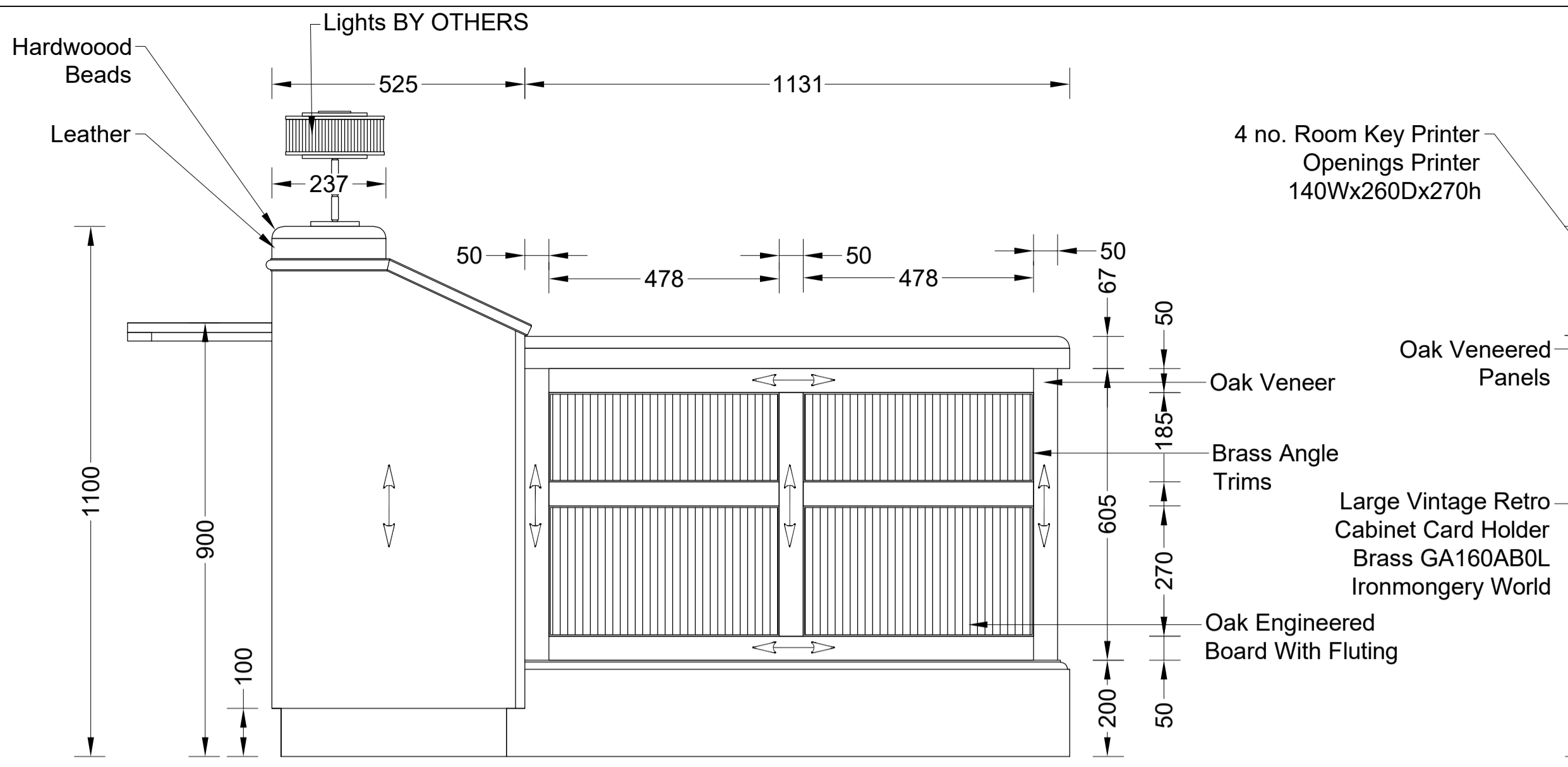

NOTE:
CLIENT TO ADVISE ON PANEL REQUIREMENTS FOR SOUND CONTROL etc.

NOTE:
CLIENT TO ADVISE ON PANEL REQUIREMENTS FOR SOUND CONTROL etc.

REV	DATE	DESC	DRAWN
E	23.03.2023	UPDATED TO COMMENTS	mpc
D	09.12.2022	UPDATED TO COMMENTS	mpc
C	17.11.22	Amended To Comments	BC

CONSTRUCTION

JOYCE & REDDINGTON
J & R House, Conduit Road, Norton Canes, Cannock, Staffordshire, WS11 9TJ
Telephone: 01543 272726 Facsimile: 01543 272726
email: info@joyceandreddington.com www.joyceandreddington.com

CLIENT: **Ruby Hotels**

PROJECT TITLE: **Vine Hill**

DRAWING TITLE: **Public Area Self Check In Unit**

DRAWN	BC	DATE	01.08.22	SCALE	1:10
DRAWING NO:	JR-VH-102	REVISION:	E		