

NOISE EMISSION DATA – PHOENIX LIFTS

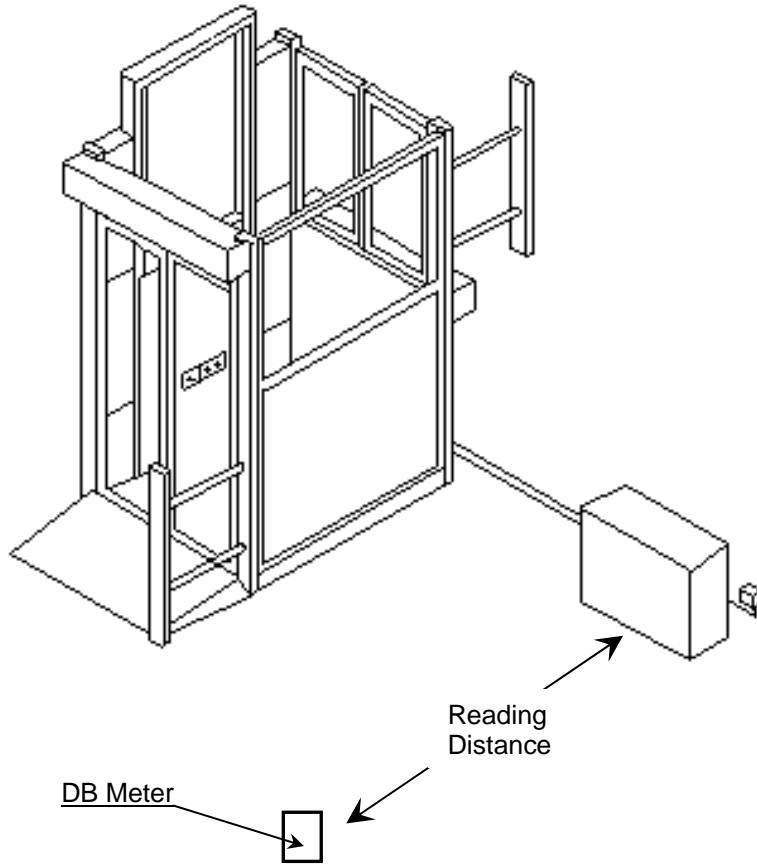

DATA RELATING TO SAM HYDRAULICS PUMP-SET

Reading Description	Reading Distance (from control cabinet)	Measurement (dba)
Standard Background Noise	-	52.0
With lift in operation (RAISING)	1000mm	66.0
	5000mm	63.0
With lift in operation (LOWERING)	1000mm	59.0
	5000mm	59.0