

## Construction Method Statement

15 Lyndhurst Terrace,  
London, NW3 5QA

Job No.: 3317

Client: Richard and Penelope Murley

Date: July 2023

Office: 020 7625 6106  
9XD

.....3 Knoll House, 77 Carlton Hill, London, NW8

Web: [www.ConceptConsultancy.eu](http://www.ConceptConsultancy.eu)

Mobile: 07955 919824 UK 086 8235150 Ireland

# Concept Consultancy

Chartered Civil & Structural Consulting Engineers

Office: 020 7625 6106 .....3 Knoll House, 77 Carlton Hill, London, NW8  
9XD  
Web: [www.ConceptConsultancy.eu](http://www.ConceptConsultancy.eu)  
Mobile: 07955 919824 UK 086 8235150 Ireland

# Concept Consultancy

Chartered Civil & Structural Consulting Engineers

## 1.0 EXECUTIVE SUMMARY

Concept Consultancy has been commissioned by Richard and Penelope Murley to prepare a Structural Method Statement for the proposed new basement at 15 Lyndhurst Terrace, London NW3.

This report forms part of the planning application and describes the design of the structural solution for the proposed basement and structural alterations.

The proposals are to demolish the existing house and construct a new house with a larger footprint and a basement over the full footprint of the house.

A thorough desk study of the site has been carried out which indicates that the site is underlain by the London Clay formation. In addition, a site investigation was carried out by Site Analytical services Ltd. which has confirmed the existing ground is grey, brown silty sandy CLAY to a depth of at least 15m.

There are no London Underground Tunnels or Overground Rail lines within 0.5km of the site, however this is a network rail tunnel 25m to the South of the site.

The site is located in within a 'Very Low Risk' flood area as defined by the Environment Agency.

The temporary works will be required to limit any movements in the neighboring buildings.

This report demonstrates how all the relevant design issues have been addressed and where any constraints has impacted on the construction of the basement.

## 2.0 INTRODUCTION

Concept Consultancy has been commissioned by Richard & Penelope Murley to prepare a Structural Method Statement for the proposed new basement at 15 Lyndhurst Terrace, London NW3.

Regarding my qualifications and credentials, I am a chartered member of the institution of structural engineers with more than twenty-five years' experience. My qualifications and affiliations are as follows in abbreviated form BEng, CEng, MIStructE, MIEI.

## 2.1 Site Location

The site is located at 15 Lyndhurst Terrace, in the Borough of Camden, London NW3. It is approximately centered at National Grid Reference TQ2663285316.

The site is rectangular in shape and measures approximately 25m x 9.5m. The site presently contains a two-story detached residential building just off Lyndhurst Terrace.

## 2.2 Site History

The contains an existing house which was built in the 1930's. It is proposed to extend the existing house and construct a new single-story basement below the full foot print of the extended house.

## 2.3 Existing Building & Site Conditions

The existing property is a detached two-story building. It is situated just of Lyndhurst Terrace near the junction with Thurlow Road.

There are no trees within the property boundary, however there are 3 No. trees within adjacent properties:

- Horse Chestnut tree 3m from the Northern boundary of the site to the North East of the existing house.
- Yew tree 7, from the Western boundary of the site.
- Bay tree 11m from the Western boundary of the site.

# Concept Consultancy

## Chartered Civil & Structural Consulting Engineers

A desktop review of Geological maps indicates the ground to be underlain by CLAYGATE MEMBER – Clay, Silt & Sand.

A site investigation was carried out by Site Analytical Services Ltd. This comprised of 3 No. borehole in the (2 No. at the front and 1 No. at the rear of the existing house) and 1 No. trial pits (to the rear). The boreholes indicated a sandy, silty CLAY to a depth of 3.75m to 4m below ground level (BEGL). This changes to a medium dense yellow brown slightly clayey silty fine SAND to a depth of 5.9m to 6.5m BEGL at the front of the site but was not present at the rear of the site. Below this a stiff orange, brown CLAY was found to depths f at least 15m BEGL.

Trail hole No. 2, to the rear indicated top of existing foundations at 380mm BEGL. The foundation comprises of a 160mm mass concrete projection beyond the wall founded at a level of 550mm BEGL. No ground water was encountered in any of the hole/pits. A copy of the Site Investigation report are contained in appendix B.

The 3 No. boreholes were subsequently monitored for ground water between July 2015 and Feb 2021. No ground water was recorded during this time.

The nearest surface water is the Hampstead No. 1 Pond approximately 750m North East of the site. The underground rivers Westbourne & Tyburn run to the South West of the site. It is a considerable distance from the site and unlikely to have an influence on this development.

The building is currently in a good condition for its age and the original building fabric is in good condition.

## 2.4 Proposed Works

It is proposed to extend the existing dwelling house at the rear and construct a new basement under the majority of the existing building footprint of the house including a front and rear light well.

The new basement walls shall be reinforced concrete retaining walls which will also underpin the existing house structure where they coincide. The front light well shall also be formed with reinforced concrete walls. The proposed basement excavations shall be approximately 3.2m below existing ground level.

A drained cavity shall be constructed inside the perimeter basement walls to capture any seepage of ground water. This water shall be drained to a new sump and pumped back up to the surface water drainage network at ground level.

The existing drainage layout will be surveyed to determine the layout and depth of the existing drainage network. The existing drainage around the perimeter of the building will most likely need to be rerouted in part to allow the construction of the new ground floor extension. Foul drainage from the new basement will be pumped back up the foul network.

### 3.0 Party Wall Matters

The proposed development falls within the scope of the Party Wall Act 1996. Procedures under the act will be dealt with in full by the Employers Party Wall Surveyor. The contractor will provide the Party Wall Surveyor with a detailed method statement and temporary works drawings.

The works shall be carried out so as not to preclude or inhibit future works on the adjoining property.

### 4.0 Adjacent Structures

The adjacent property to the South (No. 13 Lyndhurst Terrace) is a 4 storey building of brick construction including a lower ground floor. The building is approx. 3m (1.5m from the boundary) away from the proposed new basement walls. To the North there is a single storey detached garage (belonging to 'Elm Bank') of brick construction. The south wall of the garage is constructed on the property boundary and is approx. 1.5m from the existing house and from the proposed new basement walls.

To the North and adjacent to the rear garden of no. 15 Lyndhurst Terrace is 'Elm Bank' house (No. 17 Lyndhurst Terrace). The corner of the adjacent house is approximately 3m from the proposed new rear extension to No. 15 and the new basement walls. Elm Bank House is a 2 storey building with a single-story annex located being the closest to No. 15. It is not known if this property has an existing basement.

The adjacent building (and all other buildings within the immediate area) are Category 6 structures in accordance with table B.1 of BS ISO 4866:2010 which would be described as having a medium

# Concept Consultancy

## Chartered Civil & Structural Consulting Engineers

resistance to vibration and therefore would require little or no protection against vibration for the type of works proposed. It is noted that:

- The basement floor construction will not be lower than the prevailing groundwater level in this area so will not interfere with the natural flow of the groundwater.
- The building will be formed off of stiff London Clay, which has a significant bearing capacity, and the foundations will be designed to reflect the recommended permissible pressures and ensure they will not be compressed by more than 5mm
- Removal of the existing soil will, ultimately generate little or no relief and consequent heave in the London Clay.
- The boundary walls can be retained safely and easily following industry-standard practices and, by following a pre-determined sequence will allow the basement wall to be constructed without detriment to the existing, surrounding construction.

Adopting a controlled and sequenced work process will limit any damage to surrounding buildings to Category 1 on The Burland Scale, Hairline or Very Slight cracks, easily repaired with filling & decoration.

The existing foundations of the adjacent property are expected to be stepped brick on a concrete strip footing.

### 4.1 Potential Impact on Adjacent Structures

The proposed works, if executed correctly and in accordance with the permanent and temporary works design requirements and procedures, will pose no significant threat to the structural stability of the adjoining properties.

The project will be monitored during the course of the works to record any movements which occur and will be regularly inspected throughout construction to ensure that the temporary works have been installed and the permanent works are carried out correctly.

The major risk of movement in projects like this is due to poor workmanship during the construction and a major component of the likely settlement can be eliminated by appointing an experienced contractor, who undertakes the works using good practice and in accordance with the structural design. The contractor must follow all agreed method statements, installing all necessary temporary vertical and lateral supports required. The contractor will be required to submit for approval prior to

# Concept Consultancy

## Chartered Civil & Structural Consulting Engineers

construction, method statements and proposed temporary support details. All of these details will be made available and agreed with all relevant parties under the Party Wall Agreement prior to the start of any works.

### 5.0 Hydrogeological Impact

The Environment Agency information relating to the controlled waters is summarised below.

#### **Ground Water Vulnerability**

Superficial Deposits: The site is located above a secondary aquifer (refer to Basement Impact Assessment), however no groundwater was recorded in the stand pipes as noted in section 2.3  
Bedrock London Clay is an unproductive stratum

#### **Surface Water Features**

The nearest surface water is the Hampstead Heath Pond No.1 which is approximately 760m north east east of the site.

#### **Flood Risk**

The Site is in Environment Agency Flood Risk Zone 1 – Low Probability

### 6.0 Underground Structures

There are no London Underground Tunnels or Overground Rail lines within 0.5km of the site, however this is a network rail tunnel 25m to the South of the site. Given the distance from the site therefore will not affect the design of the proposed basement.

### 7.0 Construction Methodology for New Basement Walls

The proposed sequence of works is expected to be as follows:

- Remove existing ground floor.
- Reduce ground level.
- Excavate for new RC retaining wall underpinning in a hit and miss fashion.
- Install basement wall propping.
- Reduce central ground level.
- Install basement slab



# Concept Consultancy

Chartered Civil & Structural Consulting Engineers

- Install new ground floor
- Construct internal liner walls.

## 7.1 Temporary Works

The construction of the new basement will require the following temporary works:

- Temporary propping to support the top of new perimeter retaining walls during the excavation of the basement.
- Temporary propping of the lower section of the perimeter underpinning/retaining walls until the basement slab is complete.

## 7.2 Noise & Vibration

The Contractor shall undertake the works in such a way as to minimise noise, dust and vibration when working close to adjoining buildings to protect the amenities of the nearby occupiers. All piling for the new basement will be constructed using a hit and miss underpinning of the existing structure and then an excavation of the remaining ground inside. Construction noise and vibration to adjacent properties will be minimised.

The breaking out of existing structure shall be carried out by saw cutting where possible to minimise vibration to the adjacent property and associated construction noise. All demolition and excavation work will be undertaken in a carefully controlled sequence, considering the requirement to minimise vibration and noise.

# Concept Consultancy

Chartered Civil & Structural Consulting Engineers

## 8.0 Conclusion

Based on this study we believe the basement could be constructed with little impact on the surrounding property and environment.

Nothing further occurs.

Sincerely,

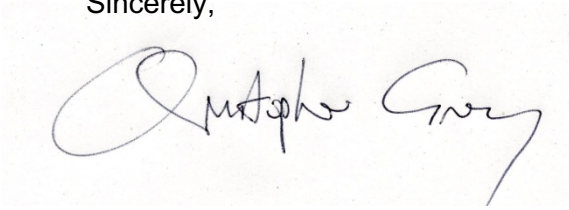
A handwritten signature in black ink, appearing to read 'Christopher Grey', is written over a light-colored rectangular background.

---

Christopher Grey

[cgrey@conceptconsultancy.eu](mailto:cgrey@conceptconsultancy.eu)

Chartered Engineer for and on behalf of

**Concept Consultancy Structural Designers Ltd.**

+44 (0)7955 919824 UK & +353(0)86 8235150 IRE

# Concept Consultancy

Chartered Civil & Structural Consulting Engineers





## Appendix A – Draft Structural Scheme & Underpinning Construction Sequence

STRUCTURAL MEMBER SCHEDULE	
REF.	MEMBER SIZE
BEAMS	
B1	250x50 TIMBER JOIST @ 400mm c.c.
B2	254x254x73 UC
B3	305x305x97 UC
B1	250x50 TIMBER JOIST @ 400mm c.c.
COLUMNS	
C1	xx

**NOTES:**

- All timbers to be C16 unless noted otherwise.
- Non-loadbearing stud partitions to be constructed with 100mm x 50mm studs at 400mm centres.
- Provide 2 rows of noggings on all stud partitions.
- Ensure legs of hangers turned over back of wall plate before fixing.
- Use 30x5x1200 straps at 1500 c/c to all roof timbers and roof joists.
- Timber beams to be bolted together as required with M10 bolts @ min 600 c/c.
- All concrete to be grade C35N20 UNO.
- All steel to be grade S275 UNO.

**LEGEND**



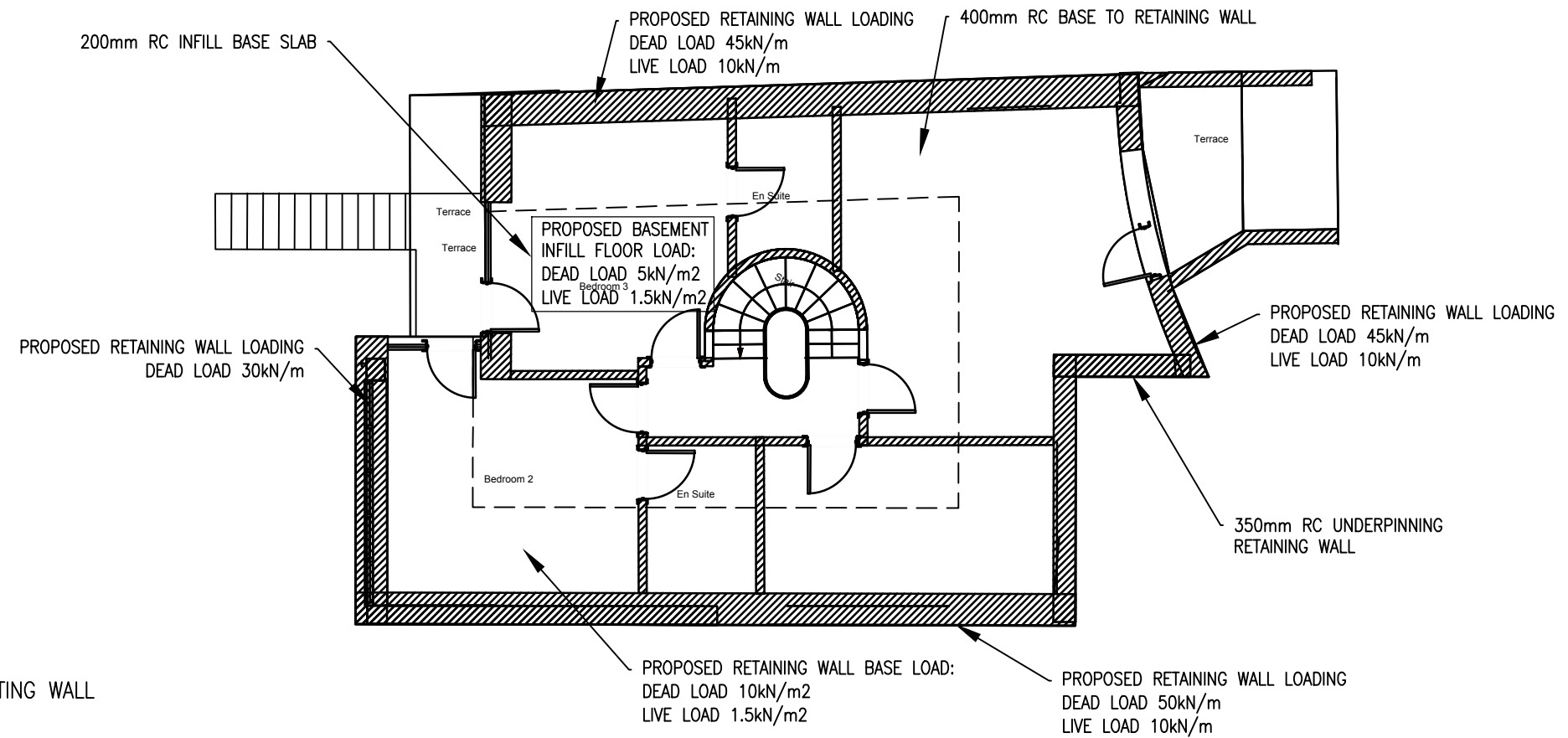

-  EXISTING WALL
-  EXISTING STRUCTURAL WALL UNDER
-  EXISTING WALL TO BE DEMOLISHED
-  NEW STRUCTURAL WALL
-  NEW STUD PARTITIONS



STRUCTURAL MEMBER SCHEDULE	
REF.	MEMBER SIZE
BEAMS	
B1	250x50 TIMBER JOIST @ 400mm c.c.
B2	254x254x73 UC
B3	305x305x97 UC
B1	250x50 TIMBER JOIST @ 400mm c.c.
COLUMNS	
C1	xx

- NOTES:**
- All timbers to be C16 unless noted otherwise.
  - Non-loadbearing stud partitions to be constructed with 100mm x 50mm studs at 400mm centres.
  - Provide 2 rows of noggings on all stud partitions.
  - Ensure legs of hangers turned over back of wall plate before fixing.
  - Use 30x5x1200 straps at 1500 c/c to all roof timbers and roof joists.
  - Timber beams to be bolted together as required with M10 bolts @ min 600 c/c.
  - All concrete to be grade C35N20 UNO.
  - All steel to be grade S275 UNO.

**LEGEND**

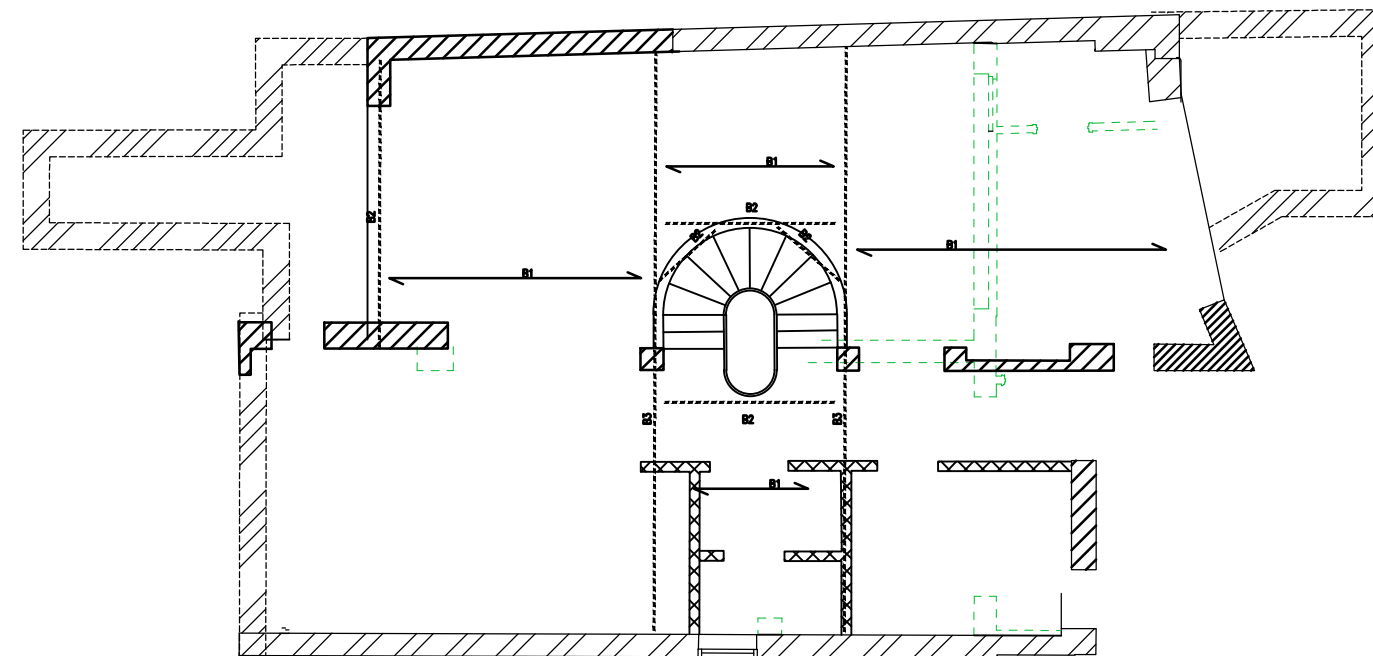

-  EXISTING WALL
-  EXISTING STRUCTURAL WALL UNDER
-  EXISTING WALL TO BE DEMOLISHED
-  NEW STRUCTURAL WALL
-  NEW STUD PARTITIONS

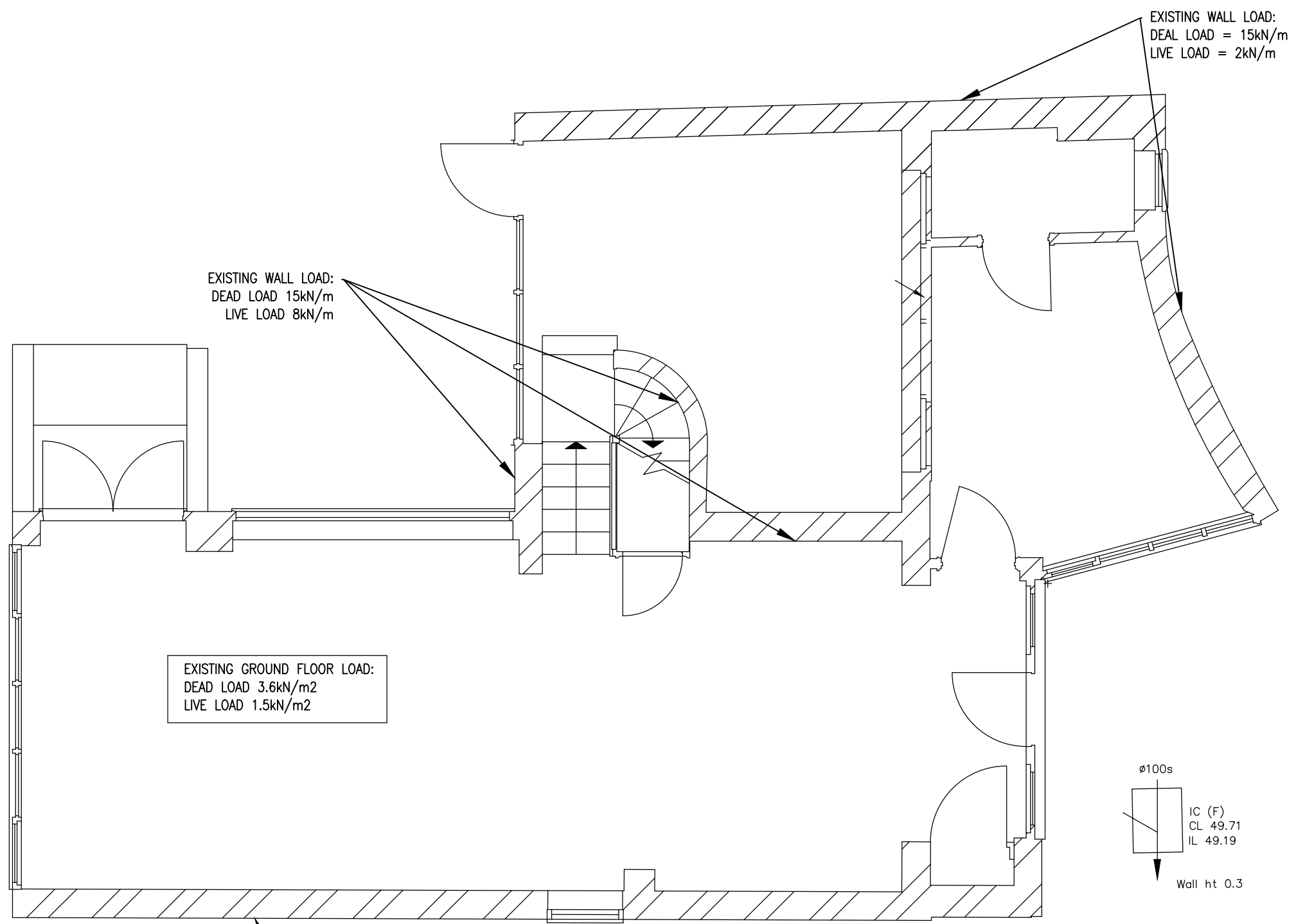

STRUCTURAL MEMBER SCHEDULE	
REF.	MEMBER SIZE
BEAMS	
ExB1	TBC
ExB2	TBC
ExB3	TBC
ExB4	TBC



LEGEND

-  EXISTING WALL
-  EXISTING STRUCTURAL WALL UNDER
-  TRIAL HOLES

A	xx/xx/2023	GW	xxxxx
Revision	Date	Made by	Amendments

Date	20-01-2021	Drawn by	GW	Checked	CG
Scales	1:50@A3	Job No.	3317	Drawing No.	50
				Revision	A

## GENERAL NOTES

- ALL STRUCTURAL ENGINEERING DRAWINGS ARE TO BE READ WITH THE STRUCTURAL SPECIFICATION AND IN CONJUNCTION WITH ALL OTHER RELEVANT ARCHITECTS, ENGINEERS & OTHER SPECIALISTS' DRAWINGS & SPECIFICATIONS
- DO NOT SCALE FROM STRUCTURAL DRAWINGS. WORK TO FIGURED DIMENSIONS ONLY. ALL DIMENSIONS IN mm U.N.O. ALL LEVELS IN m A.O.D U.N.O.
- SETTING OUT TO BE VERIFIED WITH CA PRIOR TO CONSTRUCTION & WHERE APPLICABLE, ALL DIMENSIONS & RELATIONSHIPS TO BE DETERMINED ON SITE BY CONTRACTOR BEFORE FABRICATION COMMENCES. ALL SETTING-OUT TO BE TAKEN FROM THE ARCHITECTS DRAWINGS.
- REFER TO ARCHITECTS DRAWINGS FOR INFORMATION ON FINISHES, DOORS, WINDOWS, LIGHTING, NON STRUCTURAL WALLS, LANDSCAPING, PAVING, WATERPROOFING. ALL BRACKETS & FIXINGS FOR THE SUPPORT OF THE FINISHES ARE SHOWN ON THE ARCHITECT'S DRAWINGS.
- ALL WATER & DAMP PROOFING WORKS TO BE TO ARCHITECT'S DETAILS. WHERE THIS DRAWING SHOWS WATERPROOF OR DAMP PROOF MEMBRANES, THEY ARE SIMPLY INTENDED TO INDICATE THEIR POSITION IN RELATION TO THE STRUCTURE. THE MEMBRANES HAVE BEEN DESIGNED, SPECIFIED & DETAILED BY THE ARCHITECT OR THE MANUFACTURERS ARE TO BE INSTALLED AS SHOWN ON THEIR DRAWINGS.
- ALL FIRE PROTECTION WORKS ARE TO THE ARCHITECT'S DETAILS UNLESS SPECIFICALLY NOTED OTHERWISE.
- ALL FLOOR SEPARATION DETAILS & ACOUSTIC ISOLATION ARE TO THE ARCHITECT'S DETAILS.
- ALL EXTERNAL WORKS, LANDSCAPING, PAVING ETC. ARE TO THE ARCHITECT'S DETAILS.
- TYPICALLY, ALL NON-LOAD BEARING PARTITIONS ARE OMITTED FOR CLARITY. REFER TO THE ARCHITECT'S DRAWINGS FOR DETAILS.
- IF IN DOUBT ABOUT THE INFORMATION SHOWN ON THIS DRAWING OR ANY RELATED DRAWING - ASK
- THE CONTRACTOR SHALL BE RESPONSIBLE FOR THE STABILITY OF THE EXISTING STRUCTURES ON THE SITE AND MUST TAKE ALL NECESSARY PRECAUTIONS TO SAFEGUARD THE STABILITY.
- ANY TEMPORARY WORKS INCLUDING, NEEDLING, SHORING, STRUTTING AND PROPPING SHALL BE THE SOLE RESPONSIBILITY OF THE CONTRACTOR.
- ALL DEMOLITION WORKS SHALL BE UNDERTAKEN STRICTLY IN ACCORDANCE WITH THE PARTY WALL AGREEMENTS.
- ALL INFORMATION ON THE EXISTING STRUCTURE IS TO BE CHECKED AND CONFIRMED ON SITE AND ANY DISCREPANCIES REPORTED TO THE ENGINEER PRIOR TO COMMENCEMENT OF WORKS.
- THE CONTRACT STRUCTURAL DRAWINGS AND SPECIFICATIONS REPRESENT THE FINISHED STRUCTURE. THEY DO NOT INDICATE THE METHOD OF CONSTRUCTION. THE CONTRACTOR SHALL PROVIDE ALL MEASURES NECESSARY TO PROTECT THE STRUCTURE DURING CONSTRUCTION. SUCH MEASURES SHALL INCLUDE, BUT NOT BE LIMITED TO BRACING, SHORING OF LOADS DUE TO CONSTRUCTION EQUIPMENT, ETC. BEFORE RELATED WORK COMMENCES THE CONTRACTOR SHALL SUBMIT A METHOD STATEMENT AND SEQUENCE OF WORK TO THE ENGINEER AND ARCHITECT.
- CONSTRUCTION MATERIAL SHALL BE SPREAD OUT IF PLACED ON FRAMED FLOORS OR ROOF, IN SUCH A MANNER THAT THE STRUCTURE IS NOT OVERLOADED IN EITHER THE PERMANENT OR TEMPORARY CONDITION.
- WHERE REFERENCE IS MADE TO VARIOUS TEST STANDARDS FOR MATERIALS, SUCH STANDARDS SHALL BE THE LATEST EDITION AND/OR ADDENDUM. OTHER STANDARDS MAY BE CONSIDERED BUT ONLY WITH PRIOR APPROVAL BY THE ENGINEER.
- CONTRACTOR TO ESTABLISH AND VERIFY ALL OPENINGS AND INSERTS FOR ARCHITECTURAL, MECHANICAL AND PLUMBING WITH APPROPRIATE TRADES, DRAWINGS AND SUBCONTRACTOR PRIOR TO CONSTRUCTION.
- OPTIONS ARE FOR CONTRACTORS CONVENIENCE. HE SHALL BE RESPONSIBLE FOR ALL CHANGES NECESSARY IF HE CHOOSES AN OPTION AND HE SHALL CO-ORDINATE ALL DETAILS.
- ALL DIMENSIONS ON DRAWINGS ARE IN MILLIMETRES UNLESS OTHERWISE NOTED. WRITTEN DIMENSIONS ONLY APPLY. DRAWINGS ARE NOT TO BE SCALED. ALL LEVELS ARE IN METRES U.N.O.
- FOR CLARITY, ALL ROOF AND FLOOR OPENINGS MAY NOT BE SHOWN ON FRAMING PLANS. FOR EXACT SIZE, NUMBER AND LOCATION FOR OPENING, SEE ARCHITECTURAL, MECHANICAL, ELECTRICAL AND PLUMBING DRAWINGS. WHERE OPENINGS ARE INDICATED ON THE STRUCTURAL DRAWINGS, THESE ARE TO BE CHECKED BY THE CONTRACTOR AGAINST RELEVANT SERVICE ENGINEERS OR SUBCONTRACTORS DRAWINGS PRIOR TO CONSTRUCTION.
- ALL LEVELS ARE RELATED TO THE ORDINANCE DATUM (OD)
- THE CONTRACTOR SHALL NOTE, AND MAKE ALLOWANCES FOR, THE MEASURES NECESSARY TO COMPLY WITH THE WASTE MINIMISATION AND RECYCLING TARGETS SET OUT IN SPECIFICATION.
- FOR DETAILS AND SETTING OUT OF RWP, SVP, WVP AND ALL OPENINGS SEE THE RELEVANT ARCHITECTS DRAWINGS.

### ABBREVIATIONS:

CJ	-	CONSTRUCTION JOINT
CRS	-	CENTRES
C/C	-	CROSS CENTRES
CJ	-	COLUMN UNDER
DIM	-	DIMENSION
DIA	-	DIAMETER
EGL	-	EXISTING GROUND LEVEL
DJ	-	DOUBLE JOIST
FFL	-	FINISHED FLOOR LEVEL
GA	-	GENERAL ARRANGEMENT
IP	-	INTERSECTION POINT
MAX.	-	MAXIMUM
MC	-	MASS CONCRETE
MJ	-	MOVEMENT JOINT
MS	-	MILD STEEL
NTS	-	NOT TO SCALE
OD	-	OUTER DIAMETER
PC	-	PRECAST CONCRETE
RC	-	REINFORCED CONCRETE
SOP	-	SETTING OUT POINT
SS	-	STAINLESS STEEL
SSL	-	STRUCTURAL SLAB LEVEL
TOC	-	TOP OF CONCRETE
TOS	-	TOP OF STEEL
TOW	-	TOP OF WALL
TOU	-	TOP OF UPSTAND
TYP	-	TYPICAL
TJ	-	TRIPLE JOIST
UNO	-	UNLESS NOTED OTHERWISE
U/S	-	UNDERSIDE
VB	-	VERTICAL BRACING
Ø	-	DIAMETER

## CONSTRUCTION DESIGN & MANAGEMENT

- CONCEPT CONSULTANCY ARE PROJECT 'DESIGNERS' AS DEFINED IN THE CDM REGULATIONS.
- CONCEPT CONSULTANCY HAVE ASSUMED A COMPETENT & EXPERIENCED CONTRACTOR WILL BE EMPLOYED. CONCEPT CONSULTANCY HAVE CARRIED OUT A RISK ASSESSMENT TO IDENTIFY UNUSUAL RISKS. THIS RISK ASSESSMENT IS CONTAINED WITHIN THE HEALTH & SAFETY PLAN.
- PARTY WALL AWARDS TO BE SUBMITTED BY THE CA TO THE RELEVANT ADJOINING PROPERTIES. THE CONTRACTOR IS TO COMPLY WITH THE PARTY WALL AWARD REQUIREMENTS.
- THE CONTRACTOR IS RESPONSIBLE FOR VERIFYING ALL SITE LEVELS & SETTING OUT DIMENSIONS, INCLUDING 'AS BUILT' POSITIONS OF TEMPORARY WORKS, BEFORE COMMENCING THE WORKS. THE CONTRACTOR MUST CARRY OUT AN EXACT SITE SURVEY TO CONFIRM ALL FINAL LEVELS & SETTING OUT. ANY DISCREPANCIES THAT MAY EXIST BETWEEN DRAWINGS AND ANY OTHER RELATED DOCUMENT SHOULD BE NOTIFIED TO THE CA IMMEDIATELY.
- ALL WORK TO BE CARRIED OUT TO THE SATISFACTION OF THE CA.
- THE CONTRACTOR IS ADVISED TO VISIT THE SITE TO SATISFY HIMSELF REGARDING THE PRACTICABILITY OF THE WORKS.
- CHECKING - THE ENGINEER'S COMMENTS ON SUB-CONTRACTORS DRAWINGS WILL CENTRE ON COMPLIANCE WITH THE DESIGN INTENT & EXCLUDE DIMENSIONAL CHECKS.

## CONSTRUCTION

- ALL WORKMANSHIP, MATERIALS & LOADING TO BE IN STRICT ACCORDANCE WITH THE LATEST EDITIONS OF BUILDING REGULATIONS, MANUFACTURERS SPECIFICATIONS & RECOMMENDATIONS:

BS EN 1991 ACTIONS ON STRUCTURES  
BS EN 1997 FOUNDATIONS AND EARTH RETAINING STRUCTURE  
BS EN 1993 STEELWORK  
BS EN 1992 & BS 8500 CONCRETE & BS 7543 DURABILITY  
BS EN 1996 UNREINFORCED AND REINFORCED MASONRY  
BS 6180 BALUSTRADING AND HAND RAILING

- THE CONTRACTOR IS RESPONSIBLE FOR THE DESIGN & SUPPLY OF ALL TEMPORARY WORKS (I.E. BRACING, PROPPING, SHORING & TYING) & THE STABILITY OF THE WORKS DURING CONSTRUCTION. THEY MUST SUBMIT THEIR PROPOSALS TO THE STRUCTURAL ENGINEER SUFFICIENTLY IN ADVANCE OF THE WORK COMMENCING. UNDER NO CIRCUMSTANCES WILL ANY STRUCTURAL ALTERATIONS BE CARRIED OUT PRIOR TO THE STRUCTURAL ENGINEER COMMENTING ON THE CONTRACTORS TEMPORARY WORKS PROPOSALS.
- IF AN INDEPENDENT CHECK ON THE TEMPORARY WORKS IS DEEMED TO BE NECESSARY BY CONCEPT CONSULTANCY, THE CONTRACTOR SHALL SUPPLY SUCH INFORMATION AS IS REQUIRED BY THE CHECKER TO OBTAIN APPROVAL.
- THE CONTRACTOR SHALL PREPARE & SUBMIT HIS OWN CONSTRUCTION SEQUENCE/METHOD OF CONSTRUCTION TO THE CA & CONCEPT CONSULTANCY PRIOR TO COMMENCEMENT OF WORK ON SITE. IT SHOULD BE ADHERED TO & ANY VARIATION TO THIS SHOULD BE AGREED IN ADVANCE WITH CONCEPT CONSULTANCY. THE CONTRACTOR IS RESPONSIBLE FOR PROGRAMMING THE WORKS.
- NO CONSTRUCTION METHODOLOGY THAT CAUSES A MODIFICATION OF THE PERMANENT WORKS WILL BE ACCEPTED.
- THE CONTRACTOR SHALL, AT THE OUTSET, ESTABLISH WITH THE LOCAL AUTHORITY THEIR REQUIREMENT FOR INSPECTING THE WORKS & ADHERE TO THESE.
- THE CA IS RESPONSIBLE IN SUBMITTING ALL DRAWINGS & CALCULATIONS FOR OBTAINING BUILDING REGULATION APPROVAL PRIOR TO CONSTRUCTION.
- ALL SPECIALIST NAMED MATERIALS AND PROPRIETARY PRODUCTS ARE TO BE USED & FULLY FIXED IN ACCORDANCE WITH THE MANUFACTURERS INSTRUCTIONS. ALTERNATIVE PRODUCTS TO THOSE NAMED ON THE DRAWINGS ARE SUBJECT TO APPROVAL BY CONCEPT CONSULTANCY.
- ALL JOINTS ARE DESIGNED FOR THE RANGE OF MOVEMENTS OF THE COMPLETED STRUCTURE. THE CONTRACTOR MUST ENSURE THAT THE CONSTRUCTION METHODOLOGY DOES NOT REQUIRE THESE JOINTS TO ALTER.
- ALL PLANT AND ITS SUPPORTS TO BE ADEQUATELY ISOLATED FROM THE STRUCTURE (I.E. ANTI VIBRATION MOUNTINGS). REFER TO DETAILS BY OTHERS.

## REINFORCED CONCRETE

- CONCRETE CONSTRUCTION TO BE IN ACCORDANCE WITH THE SPECIFICATION, BS EN 1992.
- ALL CONCRETE SHALL BE IN ACCORDANCE WITH BS EN 206.
- CONCRETE MIXES IN ACCORDANCE WITH CONCEPT CONSULTANCY SPECIFICATION.
- CEMENT SHALL BE ORDINARY PORTLAND CEMENT COMPLYING WITH BS EN 13139 UNLESS OTHERWISE APPROVED.
- REINFORCEMENT SHALL BE HOT ROLLED DEFORMED BARS COMPLYING WITH BS EN 10080 (Grade B500B). ALL HIGH YIELD BARS SHALL BE DEFORMED BARS TYPE 2.
- STEEL FABRIC SHALL COMPLY WITH BS EN 10080 (Grade B500B).
- ALL STAINLESS STEEL REINFORCEMENT SHALL CONFORM TO BS EN 10080 & BS 6744 (RIBBED, GRADE - TBC).
- ALL STEEL REINFORCEMENT BAR AND STEEL FABRIC REINFORCEMENT SHALL BE CUT AND BENT IN ACCORDANCE WITH BS EN 10080.
- ALL STEEL REINFORCEMENT BAR AND STEEL FABRIC REINFORCEMENT SHALL BE OBTAINED FROM A FIRM HOLDING CARES CERTIFICATE OF APPROVAL FOR THE PRODUCTION AND SUPPLY OF REINFORCEMENT.
- FOR WATERPROOFING/ FINISHES TO SLABS, WALLS AND COLUMNS REFER TO ARCHITECT DRAWINGS
- INSERTS SHALL BE PROVIDED AS NECESSARY, INCLUDING SUPPORT FOR MASONRY AND SERVICES. REINFORCEMENT SHALL BE ADJUSTED TO SUIT. PLASTIC TAPE SHALL BE USED TO PREVENT CONTACT OF DISSIMILAR METALS
- ALL READY MIX CONCRETE SHALL BE PRODUCED AT AN APPROVED "READY-MIX" BATCHING PLANT WHICH MUST BE CERTIFIED AS A "QSRMIC ACCREDITED PLANT" UNDER THE QUALITY SCHEME OF THE BRITISH READY MIXED CONCRETE ASSOCIATION. SUCH ACCREDITATION IS TO CONTINUE DURING THE WHOLE PERIOD OF CONCRETE PRODUCTION FOR THE WORKS. HOWEVER, SHOULD THE CONTRACTOR WISH TO MIX CONCRETE ON SITE, HE MUST SUBMIT. HOWEVER, SHOULD THE CONTRACTOR WISH TO MIX CONCRETE ON SITE, HE MUST SUBMIT TO CONCEPT CONSULTANCY FOR APPROVAL FULL DETAILS OF HIS PROPOSALS INCLUDING BATCHING EQUIPMENT, MIX PROPORTIONS ETC.
- REFER TO ARCHITECT'S DRAWINGS/SPECIFICATIONS FOR DETAILS OF ALL CONCRETE FINISHES.
- CONCRETE BLINDING SHALL BE C12/15N/mm2
- FOR CONCRETING IN COLD WEATHER REFER TO THE CONCRETE SPECIFICATION AND TO THE PROVISIONS OF BS EN 1992.

- THE POSITION AND TREATMENT OF CONSTRUCTION JOINTS SHALL BE TO THE APPROVAL OF THE ENGINEER.
- MOVEMENT JOINT FILLER SHALL BE A COMPRESSIBLE FIBRE BOARD SUCH AS HYDROCELL XL BY FOSROC INTERNATIONAL OR SIMILAR APPROVED.
- MOVEMENT JOINT SEALANT SHALL BE A TWO PART POLYSULPHIDE SEALANT SUCH AS THIOFLEX 600 BY FOSROC INTERNATIONAL OR AN APPROVED EQUAL, UNLESS NOTED OTHERWISE.
- CONCRETE VERTICAL SURFACES ADJOINING MASONRY WALLS SHALL BE CAST WITH A CONTINUOUS STAINLESS STEEL PROPRIETARY CHANNEL BY ANCON CCL OR SIMILAR APPROVED.
- CORE DRILLING OF ANY REINFORCED CONCRETE ELEMENTS OF THE WORK SHALL NOT BE ALLOWED WITHOUT THE PRIOR WRITTEN APPROVAL OF THE ENGINEER.
- ANCHORAGE AND LAP LENGTHS ARE TO BE IN ACCORDANCE WITH BS EN 1992.
- MINIMUM MESH LAP LENGTHS TO BE AS FOLLOWS:  
A193 MESH 300mm  
A252 MESH 400mm  
A393 MESH 500mm
- CONCRETE GRADE TO BE MIN. C32/40 UNLESS OTHERWISE NOTED ON DRAWINGS.
- PROVIDE A MINIMUM OF 24 HOURS NOTICE TO THE ENGINEER FOR INSPECTION OF ALL REINFORCING STEEL PRIOR TO PLACING CONCRETE.
- CONCRETE CUBES SHALL BE TAKEN AT A RATE OF ONE SET OF THREE CUBES PER 20m<sup>2</sup> OR FRACTION THEREOF, WITH A MINIMUM OF ONE SET PER DAY PER CLASS OF CONCRETE. CUBES SHALL BE TESTED AT 7 AND 28 DAYS. ALL THE RESULTS SHALL BE FORWARDED DIRECTLY TO THE ENGINEER.
- CONCRETE CUBES SHALL BE CURED ON SITE UNDER WATER AT 20°C FROM AS SOON AS PRACTICALLY POSSIBLE AND STORED SAFELY UNTIL TESTING. TESTING SHALL BE CARRIED OUT IN ACCORDANCE WITH BS EN 12390 AND IS TO BE UNDERTAKEN BY A UKAS APPROVED LABORATORY.
- PROOF OF TESTING WITH REPORTS AND CERTIFICATES ARE TO BE ISSUED TO THE ENGINEER FOR COMMENT AND ARE TO BE MADE AVAILABLE TO NHBC, OR OTHER INSURANCE SCHEME REPRESENTATIVES, UPON REQUEST.
- CONCRETE TOLERANCES ARE TO BE IN ACCORDANCE WITH THE LATEST EDITION OF THE NATIONAL STRUCTURAL CONCRETE SPECIFICATION OR AS NECESSARY TO ENSURE THAT THE FINISHED LINE LEVEL AND JUXTAPOSITION OF ELEMENTS IS SUCH AS TO PROVIDE THE FINISHED PRODUCT SHOWN SPECIFIED OR OTHERWISE INFERRED FROM THE DRAWINGS.
- NOMINAL COVER TO REINFORCEMENT SHALL BE AS FOLLOWS UNLESS OTHERWISE NOTED ON DRAWINGS:  
SURFACE Poured AGAINST EARTH - 75mm  
SURFACE Poured AGAINST FORMWORK BUT IN CONTACT WITH EARTH OR C12/15N BLINDING - 50mm  
BEAMS, COLUMNS - 30mm  
SLABS - 30mm
- CONCRETE FLOOR MIXTURE (U.N.O.):  
INGREDIENTS MIX  
20mm CHIP 700  
10mm CHIP 460  
SAND 770  
CEMENT 350  
WATER 140  
\*ADMIXTURE (kg) 1.86  
\*\*ADMIXTURE (ltr) 2.5  
FREE W/C RATIO 0.4  
WORKABILITY (mm) 75

- \* RP1, A STANDARD PLASTICISER  
\*\* GLENIUM C315, A SUPERPLASTICISER

## PRECAST CONCRETE

- CONCRETE CONSTRUCTION TO BE IN ACCORDANCE WITH THE SPECIFICATIONS, BS EN 1992
- ALL PRECAST CONCRETE SHALL BE IN ACCORDANCE WITH BS EN 206.
- CEMENT SHALL BE ORDINARY PORTLAND CEMENT COMPLYING WITH BS EN 197 UNLESS OTHERWISE APPROVED.
- REINFORCEMENT SHALL BE HOT ROLLED DEFORMED BARS COMPLYING WITH BS EN 10080 (Grade B500B). ALL HIGH YIELD BARS SHALL BE DEFORMED BARS TYPE 2.
- STEEL FABRIC SHALL COMPLY WITH BS EN 10080 (Grade B500B).
- ALL STAINLESS STEEL REINFORCEMENT SHALL CONFORM TO BS EN 10080 & BS 6744 (RIBBED, GRADE - TBC).
- UNITS ARE TO BE ERECTED BY COMPETENT CONTRACTORS AS APPROVED BY PRECAST SUPPLIER / MANUFACTURER, AND THE ENGINEER
- OPENINGS - NO OPES, NOTCHES OR ALTERATIONS ARE TO BE MADE TO UNITS WITHOUT PRIOR CONSULTATION WITH PRECAST SUPPLIER / MANUFACTURER.
- MORTAR SHALL COMPLY WITH THE MIX DESIGNATED FOR GRADE (II) GIVEN IN BS EN 1996 UNLESS OTHERWISE STATED ON DRAWINGS. MORTAR TESTING SHALL BE IN ACCORDANCE WITH BS EN 1015.
- THE CONTRACTOR SHALL SUBMIT FULLY DETAILED FABRICATION DRAWINGS TO THE ENGINEER FOR APPROVAL A MINIMUM OF 10 WORKING DAYS BEFORE FABRICATION IS DUE TO COMMENCE. NO FABRICATION SHALL COMMENCE UNTIL APPROVAL OF THE SHOP DRAWINGS IS RECEIVED AND UNTIL ALL COMMENTS HAVE BEEN INCORPORATED.
- APPROVAL BY THE ENGINEER IN NO WAY RELIEVES THE CONTRACTOR FOR ANY RESPONSIBILITY FOR THE ACCURACY, CORRECTNESS AND ADEQUACY OF CALCULATIONS, DESIGN, DETAILS AND DIMENSIONS.

CONCEPT CONSULTANCY  
STRUCTURAL DESIGNERS LTD  
3 Knoll House, 77 Carlton Hill - London, NW6 9XD -

Tel: 020 76256106; Mob: 07955 919824; - e-mail: info@conceptconsultancy.eu

Client  
Richard & Penelope Murley

Project  
15 Lyndhurst Terrace  
LONDON, NW3 5QA

Title  
STRUCTURAL NOTES  
SHEET 1

A	xx/xx/2020	GW.	xx
Revision	Date	Made by	Amendments

Date	20-01-2021	Drawn by	GW	Checked	CG
Scales	NTS	Job No.	3317	Drawing No.	800
				Revision	A

## MASONRY (BRICKWORK & BLOCKWORK)

- MATERIALS, COMPONENTS AND WORKMANSHIP USED IN THE CONSTRUCTION OF BRICK AND BLOCK WALLS SHALL COMPLY WITH THE RECOMMENDATIONS OF BS EN 1996.
- MATERIALS:
  - CLAY BRICKS SHALL COMPLY WITH BS EN 771.
  - PRECAST CONCRETE BLOCKS SHALL COMPLY WITH BS EN 771.
  - SAND FOR MORTAR SHALL BE ORDINARY PORTLAND CEMENT IN ACCORDANCE WITH BS EN 13139.
  - CEMENT USED IN THE MORTARS SHALL BE PORTLAND CEMENT TO BS EN 197 OR SULPHATE RESISTING CEMENT TO BS 4027 AS DIRECTED ON THE DRAWINGS.
  - LIME SHALL BE NON-HYDRAULIC (CALCIUM), SEMI-HYDRAULIC (CALCIUM) OR MAGNESIUM LIME IN ACCORDANCE WITH BS EN 459.
  - WATER SHALL BE POTABLE.
  - NO ADMIXTURES SHALL BE USED WITHOUT THE PRIOR WRITTEN CONSENT OF THE ENGINEER. MORTAR PLASTICISERS SHALL MEET THE REQUIREMENTS OF BS EN 934.
  - PIGMENTS SHALL CONFORM TO THE REQUIREMENTS OF BS EN 12878. CALCIUM CHLORIDE SHALL NOT BE USED AS AN ADDITIVE.
- MORTAR SHALL COMPLY WITH THE MIX DESIGNATED FOR GRADE (M) GIVEN IN BS EN 1996, UNLESS OTHERWISE STATED ON DRAWINGS. MORTAR TESTING SHALL BE IN ACCORDANCE WITH BS EN 1015.
- BLOCKS FOR RISING WALLS SHALL BE SOLID UNITS. BLOCK SIZES FOR OTHER AREAS SHALL BE AS INDICATED ON DRAWINGS OR SPECIFICATIONS. JOINT THICKNESS SHALL BE 10mm.
- THE CHARACTERISTIC COMPRESSIVE STRENGTH OF THE BLOCKS SHALL BE 5.0 N/mm<sup>2</sup> UNLESS NOTED OTHERWISE ON DRAWINGS. BLOCKS SHALL BE TESTED AT A RATE OF 5 PER 1000 BY AN INDEPENDENT TESTING AGENCY.
- BED JOINT REINFORCEMENT SHALL BE "BRICKFORCE REINFORCEMENT" BY BRC BUILDING PRODUCTS OR SIMILAR APPROVED. BED JOINT REINFORCEMENT SHALL BE PROVIDED IN ACCORDANCE WITH THE TYPE, SIZE AND SPACING INDICATED ON THE DRAWINGS. IT SHALL BE IN STAINLESS STEEL GRADE 304, UNLESS NOTED OTHERWISE ON THE DRAWINGS.
- RISING WALL INTERSECTIONS SHALL BE TIED TOGETHER IN A MASONRY BOND. OTHER WALLS SHALL BE TIED IN MASONRY BOND AT CORNERS UNLESS NOTED OTHERWISE ON DRAWINGS.
- WALL TIES SHALL BE IN ACCORDANCE WITH BS EN 845, SHALL BE STAINLESS STEEL (GRADE 304) AND SHALL HAVE AT LEAST 50mm EMBEDMENT INTO EACH LEAF. PARTIAL CAVITY INSULATION IS TO BE HELD IN PLACE BY PROPRIETARY PLASTIC CLIPS SUPPLIED BY THE TIE MANUFACTURER.
- BRICK AND BLOCKWORK SHALL NOT BE BUILT WHEN THE AIR TEMPERATURE IS 2°C AND FALLING. FOR MASONRY CONSTRUCTION DURING COLD WEATHER REFER TO THE SPECIFICATIONS AND THE PROVISIONS OF BS EN 1996.
- ALL RISING WALLS SHALL BE LAID WITH FULL MORTAR COVERAGE ON HORIZONTAL AND VERTICAL FACES.
- THE CONTRACTOR SHALL BE RESPONSIBLE FOR SHORING AND BRACING OF ALL MASONRY WALLS AS NECESSARY TO ENSURE STABILITY DURING CONSTRUCTION. SUCH SHORING AND BRACING SHALL BE MAINTAINED IN POSITION UNTIL THE MASONRY HAS ATTAINED ITS DESIGN STRENGTH AND THE RESTRAINING/SUPPORT STRUCTURE IS IN PLACE.
- BACK FILL SHALL NOT BE PLACED AGAINST WALLS WITHIN 10 DAYS OF COMPLETION OF THE WALL. THE MAXIMUM LEVEL DIFFERENCE BETWEEN BACK FILL ON EITHER SIDE OF A MASONRY WALL SHALL BE 225mm. HEAVY EQUIPMENT USED IN BACK FILLING SHALL NOT OPERATE CLOSER TO THE WALL THAN A DISTANCE EQUAL TO THE HEIGHT OF THE BACK FILL ABOVE THE FOOTINGS.
- REQUIREMENTS FOR REINFORCED MASONRY:
  - CONCRETE FOR FILLING CORES OR EMBEDDED REINFORCING BARS SHALL BE C28/35 UNLESS NOTED OTHERWISE ON DRAWINGS. MAXIMUM AGGREGATE SIZE 10mm.
  - VERTICAL BAR REINFORCEMENT SHALL BE SECURED IN POSITION. CAVITIES CONTAINING REINFORCEMENTS SHALL BE COMPLETELY FILLED WITH CONCRETE AND CLEAN OUT OPENINGS SHALL BE PROVIDED AT THE BASE OF VERTICAL CORES.
- FOR LINTEL DETAILS REFER TO PROJECT DETAIL DRAWINGS AND MASONRY SPECIFICATION.
- REFER TO ARCHITECTS DRAWINGS FOR DETAILS OF SETTING OUT TO MASONRY SPECIFICATION.
- REINFORCED U-BLOCK TO BE PROVIDED AT CILL LEVEL OF ALL WINDOW OPENS.
- \* DENOTES 'UBLOCK'/P.C. BUILDERS LINTEL OVER FOR ALL STANDARD BLOCKWORK OPENINGS. ALTERNATIVELY KEYSTONE ANGLE LINTELS FOR STANDARD BRICKWORK OPENINGS.
- CONTROL JOINTS TO BE PROVIDED IN BLOCKWORK AT 6m Ctrs. WALL TIES SHALL BE PLACED AT 450 Ctrs. ACROSS CONTROL JOINTS ON INTERNAL LEAVES. WALL TIES TO BE DOBONDED AT ONE END.

## TIMBER

- ALL TIMBER MEMBERS ARE TO BE MINIMUM GRADE C24 U.N.O. TO BS EN 1995, BS EN 519 & BS EN 14081. TIMBER TO BE PRESSURE IMPREGNATED WITH PRESERVATIVE AND CUT ENDS BRUSH TREATED.
- ALL JOISTS SHOWN DOUBLED OR TRIPLED ARE TO BE BOLTED TOGETHER AT MAX. 500 CRS USING M12 GRADE MIN. 4.6 BOLTS AND USING 51mm DIAMETER DOUBLE SIDED ROUND TOOTHED PLATE CONNECTORS BETWEEN TIMBERS AT EACH BOLT LOCATION U.N.O. ON DRAWINGS.
- ALL BOLTS INTO TIMBER ARE TO HAVE 50mmsq x 3mm THICK MS WASHERS BELOW NUT.
- WANE NOT PERMITTED.
- SOLID BLOCKING OR HERRINGBONE STRUTTING TO BE PROVIDED BETWEEN ALL TIMBER JOISTS OR RAFTERS AS FOLLOWS:
  - 2.5m TO 4.5m SPAN: MIDSPAN AND AT EACH END SUPPORT.
  - SPANS LONGER THAN 4.5m: TWO ROWS EQUALLY SPACED IN SPAN AND AT END SUPPORTS OUTER JOISTS OR RAFTERS TO BE BLOCKED SOLIDLY TO PERIMETER WALLS.
- LATERAL RESTRAINT STRAPS FOR FLOORS ARE TO BE MINIMUM 900mm LONG 30 x 5 GALVANIZED MS STRAPS AT 1200mm c/c WITH 150mm BOB END. STRAPS PERPENDICULAR TO JOISTS TO BE NAILED TO TOPS OF THREE JOISTS + SOLID BLOCKING INFILL USING 5, 75mm LONG, 3.8i NAILS. STRAPS PARALLEL TO JOISTS ARE TO BE LET-IN TO THE TOP OF THE JOISTS AND NAILED IN PLACE USING 6, 50 LONG, 3.4i NAILS. REFER TO TYPICAL DETAILS.
- LATERAL RESTRAINT STRAPS ARE TO BE USED TO STRAP TOGETHER JOISTS OVER STEEL JOIST ARE TO BE CONNECTED TO JOISTS WITH 3 No.12 WOOD SCREWS EACH SIDE, LATERAL STRAPS TO BE TEK SCREWED TO TOP OF STEEL BEAM.
- JOIST HANGERS - AT ALL CONNECTIONS BETWEEN TIMBER AND STEEL BEAMS U.N.O., CONTINUOUS SOLID TIMBER BLOCK TO THE WEB OF THE BEAM THROUGH BOLTED TO STEEL BEAM WITH M10 GRADE 8.8 BOLTS @600mm c/c AND JOIST HANGERS BY SIMPSON STRONG TIE OR SIMILAR APPROVED ARE TO BE PROVIDED.
- NO CHANGES TO PROVIDED TIMBER SIZES WILL BE ACCEPTED WITHOUT PRIOR APPROVAL.
- WALL PLATES FOR ROOF ARE TO BE TIED DOWN USING LONGx30x2.5 GALVANISED MS STRAPS AT 1200 CRS WITH 150 BOB END. STRAPS PERPENDICULAR TO JOISTS TO BE SCREWED TO TOPS OF 3 JOISTS + SOLID BLOCKING

USING No10 WOOD SCREWS. STRAPS PARALLEL TO JOISTS ARE TO BE LET IN TO THE TOP OF THE JOISTS AND SCREWED IN PLACE WITH No. 10 WOOD SCREWS.

- ALLOW FOR JOIST HANGERS TO ALL CONNECTIONS.
- ROOF TIMBER RAFTERS TO BE DOUBLED-UP EITHER SIDE OF ROOF LIGHTS, UNLESS NOTED OTHERWISE.

## STEELWORK & COLD FORMED PURLINS AND SHEET RAILS

- ALL STEELWORK TO BE GRADE S355 JO TO BS EN 10025 U.N.O AND IN ACCORDANCE WITH CONCEPT CONSULTANCY SPECIFICATION AND THE LATEST EDITION OF THE NATIONAL STRUCTURAL STEELWORK SPECIFICATION FOR BUILDING CONSTRUCTION CE MARKING VERSION.
- THE STEEL STRUCTURE IS EXECUTION CLASS 2 (EXC2). IT IS HIGHLY RECOMMENDED THAT THE STEEL CONTRACTOR(S) / FABRICATOR(S) APPOINTED FOR THE PROJECT ARE MEMBERS OF THE BCSA. OTHERWISE, THE MAIN CONTRACTOR OR CLIENT SHOULD COMPLETE ALL NECESSARY DUE DILIGENCE TO CHECK THAT STEELWORK BEING DELIVERED TO SITE COMPLIES WITH THE CONSTRUCTION PRODUCTS REGULATION (CPR) AND IS CE MARKED.
- ALL STEEL SHALL BE SAW CUT.
- ALL STEEL TO BE BLAST CLEAN STEEL TO SA 2 1/2
- THE FABRICATOR IS TO COMPLETE THE DETAILING OF ALL CONNECTIONS NOT FULLY DETAILED ON THE DRAWINGS, USING DESIGN CONNECTION FORCES GIVEN BY THE ENGINEER. FOR COLD FORMED SECTIONS THE FABRICATOR IS TO COMPLETE THE DETAIL DESIGN FOR THOSE ELEMENTS SHOWN ON THE DESIGN DRAWINGS, AND PRODUCE COORDINATED DRAWINGS SHOWING ALL CONNECTION DETAILS ETC.
- CONNECTIONS ARE TO BE DESIGNED AND DETAILED BY THE CONTRACTOR FOR THE MIN FORCES LISTED CALCULATIONS SHALL BE SUBMITTED FOR APPROVAL WITH THE FABRICATIONS DRAWINGS.
- ALL STRUCTURAL STEELWORK IS TO BE DESIGNED AND FABRICATED IN ACCORDANCE WITH CONCEPT CONSULTANCY SPECIFICATION CLAUSES.
- ALL STEEL TO STEEL CONNECTIONS TO COMPRISE A MINIMUM OF 2No M16, GRADE 8.8 BOLTS AND TO BE CAPABLE OF RESISTING A MINIMUM FACTORED SHEAR LOAD OF 75kN AND MIN. FACTORED TIE FORCE = 75kN. ALL MOMENT LOADS ARE TO BE TREATED AS REVERSIBLE UNO
- ALL BOLTS ARE TO BE GRADE 8.8 SHERADIZED TO BS EN 13811, CLASS 1. ALL BOLTS, NUTS AND WASHERS ARE TO BE TO BS EN 1993-1-8. WASHERS ARE TO BE PLACED BENEATH THE ROTATED ITEM.
- ANCHOR BOLTS SHALL BE GRADE 8.8 MATERIAL UNLESS STATED OTHERWISE ON THE DRAWINGS. GROUT UNDER BASE PLATES SHALL BE S80 FIVE STAR NON SHRINK GROUT OR SIMILAR APPROVED AND INSTALLED IN STRICT ACCORDANCE WITH THE MANUFACTURERS RECOMMENDATIONS. GROUT TO BE POURED WHEN COLUMNS HAVE BEEN PLUMBED, LINED AND LEVELLED. HOLDING DOWN BOLTS AND LEVELLING PACKS SHALL BE TOTALLY ENCLOSED BY GROUT.
- ALL SITE FABRICATED CONNECTIONS TO RECEIVE SITE APPLIED PRIMER & STRIPE COATS COMPATIBLE WITH EXISTING CORROSION PROTECTION SYSTEM.
- ALL CONTACT SURFACES IN FRICTION GRIP BOLTED CONNECTIONS TO BE LEFT UNPAINTED.
- ANY STEELWORK BELOW GROUND TO BE ENCASED IN CONCRETE. MINIMUM COVER TO STEEL TO BE 75mm.
- REFER TO ARCHITECT'S SPECIFICATION FOR FIRE PROOFING DETAILS.
- THE STEELWORK SUB-CONTRACTOR SHALL BE RESPONSIBLE FOR TAKING ALL NECESSARY SITE MEASUREMENTS PRIOR TO FABRICATION TO ENSURE THE CORRECT FIT OF THE NEW WORKS ON SITE.
- THE CONTRACTOR IS TO ENSURE THE USE OF NEOPRENE WASHERS OR SIMILAR SEPARATION MEDIUMS TO PREVENT BI-METALLIC REACTIONS.
- THE HOLDING DOWN BOLTS SHALL BE SUPPLIED BY THE STEELWORK SUB-CONTRACTOR AND FIXED BY THE GENERAL CONTRACTOR. THE HOLDING DOWN BOLTS & BASEPLATES ARE TO BE DESIGNED BY THE FABRICATOR.
- ALL CONNECTION PLATES TO BE THE GREATER OF 12mm, OR THE THICKNESS OF THE WEB/ FLANGE WHICH THEY JOIN IN ACCORDANCE WITH BS EN 1993.
- ALL WELDS ARE TO BE A MIN 6mm FULL PROFILE CONTINUOUS FILLET WELD (FPFW) IN ACCORDANCE WITH BS EN 1011-1 UNO. WHERE A WELD IS CALLED UP AS FULL STRENGTH BUTT WELD (FSBW) IT IS ASSUMED THAT IT WILL BE FULL PENETRATION. SITE WELDING WILL NOT BE ACCEPTABLE.
- ALL FABRICATION DRAWINGS ISSUED FOR APPROVAL WILL BE COMMENTED ON WITHIN 10 WORKING DAYS. ANY ITEMS FABRICATED PRIOR TO APPROVAL SHALL BE AT THE CONTRACTOR'S RISK.
- THE STEELWORK FABRICATOR SHALL PRODUCE AND SUBMIT TWO COPIES OF FULLY DETAILED & DIMENSIONED FABRICATION DRAWINGS TO THE ENGINEER FOR APPROVAL A MINIMUM OF 10 WORKING DAYS BEFORE FABRICATION IS DUE TO COMMENCE. NO FABRICATION SHALL COMMENCE UNTIL APPROVAL OF THE SHOP DRAWINGS IS RECEIVED AND UNTIL ALL COMMENTS HAVE BEEN INCORPORATED.
- APPROVAL BY THE ENGINEER IN NO WAY RELIEVES THE CONTRACTOR FOR ANY RESPONSIBILITY FOR THE ACCURACY, CORRECTNESS AND ADEQUACY OF CALCULATIONS, DESIGN, DETAILS AND DIMENSIONS.
- ALL COLUMNS, BEAMS AND CROSS BRACING TO BE POSITIONED SUCH THAT CENTRE LINES OF ALL MEMBERS INTERSECT AT CONNECTIONS U.N.O.
- ALL STEEL BEAMS TO BEAR ON PLATES/ BRICKWORK 100mm MINIMUM UNLESS NOTED OTHERWISE. PLATES TO BE BEDDED ON 10MM THICK MORTAR. REINSTATE BRICKWORK AROUND BEAM ENDS AND PACK VOIDS WITH MORTAR.
- WHERE BEAMS ARE SUPPORTED ON WALLS/PIERS USE 2 NO. M12 BOLTS THROUGH BOTTOM FLANGE AND CAST INTO PADSTONES U.N.O.
- COLD FORMED PURLINS AND SHEETING RAILS SHALL BE DESIGNED TO BS EN 1993-1-3 AND SHALL BE MANUFACTURED FROM HOT DIPPED GALVANISED STEEL TO BS EN 10326. STEEL SHALL BE GRADE E350 WITH A Z225 ZINC COATING UNLESS NOTED OTHERWISE.

## MOVEMENT & TOLERANCES

THE STRUCTURE HAS BEEN DESIGNED TO SATISFY THE FOLLOWING MOVEMENT CRITERIA:

STRUCTURE TYPE	LOAD TYPE	DEFLECTION	SPAN
CONCRETE STRUCTURES	LIVE LOAD	DEFLECTION	SPAN/360
STEEL STRUCTURES	LIVE LOAD	DEFLECTION	SPAN/360
	TOTAL LOAD	DEFLECTION	SPAN/250
LATERAL	WIND LOAD	DEFLECTION	SPAN/360
	STOREY SWAY		SPAN/360

GENERALLY PERMISSIBLE DEVIATIONS/TOLERANCES ARE AS PER THE NSCS/NSSS UNLESS MODIFIED BY THE CONCEPT DESIGN PROJECT SPECIFICATIONS OR NOTED ON CONCEPT DESIGN DRAWINGS.

## CONSTRUCTION TOLERANCES

- SPACE BETWEEN WALLS:
- BRICK/BLOCK = +/- 20mm
  - TIMBER STUD = +/- 32mm
- SPACE BETWEEN COLUMNS:
- STEEL = +/- 12mm
- WALL VERTICALITY:
- BRICK / BLOCK = 10mm
  - TIMBER STUD = 10mm
- COLUMN VERTICALITY:
- STEEL = 6mm
- VERTICAL POSITION OF BEAMS:
- STEEL = +/- 20mm
- VERTICAL POSITION OF FLOORS:
- INSITU / COMPOSITE = +/- 15mm
- PLAN POSITION:
- BRICK / BLOCK / STEEL / TIMBER = +/- 10mm
- FLATNESS OF FLOORS:
- UNDER 3m STRAIGHT EDGE = 5mm

## FOUNDATIONS

- CONCRETE BLINDING SHALL BE PROVIDED UNDER ALL FOUNDATIONS TO A MINIMUM THICKNESS OF 50mm. EXCAVATED SURFACES SHALL BE FREE OF LOOSE MATERIAL, DRY AND BLINDING AS SOON AS POSSIBLE AFTER INSPECTION OF BEARING SURFACES BY THE ENGINEER.
- FOUNDATIONS TO BE CENTERED UNDER COLUMNS AND WALLS UNLESS NOTED OTHERWISE ON THE DRAWINGS.
- ALL INSULATION AND DPC'S TO ARCHITECTS DETAILS.
- FINAL FORMATION LEVELS AND FOUNDATION LAYOUT TO BE AGREED ON SITE WITH ENGINEER DURING EXCAVATION AND PRIOR TO CONSTRUCTION / CASTING.
- ALL CONCRETE IN FOUNDATIONS TO BE GRADE C32/40 SRPC.
- DEPTH TO BE IN ACCORDANCE WITH NHBC STANDARDS CHAPTER 4.2.
- IF PLANT ROOTS AND/OR SOIL DESICCATION IS DISCOVERED DURING EXCAVATION FOUNDATION DEPTHS MAY HAVE TO BE INCREASED.
- REFER TO SERVICES LAYOUT FOR UNDERGROUND DRAINAGE AND DUCTING, ETC. USE PRECAST CONCRETE LINTELS OVER ALL SERVICE PIPES, ETC.

## UNDERPINNING - METHOD STATEMENT & PROCEDURE

- BEFORE STARTING THE WORK THE CONTRACTOR IS TO CHECK FOR ANY SERVICES THAT COULD BE DAMAGED BY THE UNDERPINNING WORK.
- THE CONTRACTOR SHALL BE RESPONSIBLE FOR ENSURING THAT HIS OPERATIONS DO NOT IN ANY WAY IMPAIR THE SAFETY OR CONDITION OF THE BUILDING BOTH BEFORE AND DURING THE EXCAVATION OF THE WORK AND IMMEDIATELY INFORM THE ENGINEER IF HE CONSIDERS THAT MORE STRINGENT PROCEDURES THAN THOSE SPECIFIED ARE NECESSARY.
- UNDERPINNING IS TO BE CARRIED OUT IN SHORT SECTIONS OF MAX 1.0M IN LENGTH. THE BOTTOMS OF FOUNDATION SHALL BE INSPECTED AND APPROVED BY THE ENGINEER AND THE BUILDING INSPECTOR BEFORE CONCRETE IS POURED. THE UNDERPINNING IS TO BE CARRIED OUT TO THE SATISFACTION OF THE ENGINEER AND BUILDING INSPECTOR.
- PROJECTING PORTIONS OF THE EXISTING FOOTINGS ARE TO BE CAREFULLY CUT OFF WHERE DIRECTED AND THE UNDERSIDE OF THE FOOTINGS ARE TO BE CLEANED AND HACKED FREE OF DIRT, SOIL OR LOOSE MATERIALS BEFORE UNDERPINNING.
- THE BODY OF THE UNDERPINNING IS TO BE CONSTRUCTED IN 1:2:4 MIX CONCRETE AND IS TO BE CAST TO THE WIDTHS SHOWN UNLESS OTHERWISE DIRECTED BY THE ENGINEER. EXCAVATION AND CONCRETING OF ANY SECTION OF UNDERPINNING SHALL BE CARRIED OUT ON SAME DAY.
- THE MASS CONCRETE IS TO BE STOPPED OFF 75MM BELOW THE UNDERSIDE OF THE EXISTING WALL/FOOTING AND THE FINAL FINISH UP OVER THE WHOLE WIDTH OF THE WALL/FOOTING IS TO BE CARRIED OUT WITH 1:3 MIX CEMENT TO SHARP SAND DRY PACK MORTAR WELL RAMMED IN 24 HOURS AFTER THE MASS CONCRETE HAS BEEN POURED.
- EXCAVATION TO ANY SECTION OF UNDERPINNING SHALL NOT BE STARTED UNTIL AT LEAST 48 HOURS AFTER COMPLETION OF ANY ADJACENT SECTIONS OF WORK.
- THE SIDES OF THE PREVIOUS UNDERPINNING BAYS ARE TO BE ROUGHENED OR KEYED TO THE SATISFACTION OF THE ENGINEER AND BUILDING INSPECTOR.
- SEQUENCE OF UNDERPINNING TO BE AS SHOWN. ALL SECTIONS MARKED 1 TO BE EXCAVATED, CAST AND DRY PACKED BEFORE STARTING EXCAVATION OF SECTIONS MARKED 2 AND ALL SECTIONS MARKED 2 TO BE COMPLETED BEFORE EXCAVATION FOR SECTIONS MARK 3 ETC.
- THE CONTRACTOR IS TO KEEP A RECORD OF THE SEQUENCE AND DIMENSIONS OF THE UNDERPINNING ACTUALLY CARRIED OUT, INCLUDING DETAILS OF EXCAVATION, CASTING CONCRETE AND FINISHING UP FOR EACH SECTION.
- EXCAVATED MATERIAL INTENDED FOR BACKFILLING IS TO BE KEPT PROTECTED FROM DRYING OUT OR WETTING AND IS TO BE PLACED IN MAXIMUM 150MM LAYERS, CAREFULLY COMPACTED WITH A PNEUMATIC OR ELECTRIC PERCUSSION TOOL WITH COMPACTING PLATE.

### NOTE:

- ALL UNDERPINS TO BE MAX 1000mm LONG U.N.O.
- ALL UNDERPINS TO BE DOWELLED INTO ADJACENT UNDERPINS WITH H20 DOWELL BARS @ 500C/C HORIZONTALLY AND VERTICALLY.
- 1 DENOTES CONSTRUCTION SEQUENCE FOR UNDERPINNING WORKS.
- ALL UNDERPINNING DETAILS SUBJECT TO CONFIRMATION FOLLOWING RECEIPT OF EXISTING FOUNDATION DETAILS.
- ALL UNDERPINNING DETAILS, EXTENTS & FOUNDATION SIZES T.B.C. PRIOR TO COMMENCEMENT OF WORKS ON SITE.
- FOR GROUND CONDITIONS & ALLOWABLE GROUND BEARING PRESSURE ACROSS THE SITE REFER TO SITE SPECIFIC INVESTIGATION REPORT.
- ALL WATERPROOFING TO ARCHITECTS DETAILS.

## TYPICAL REINFORCEMENT QUANTITIES

ELEMENTS:	QUANTITIES (U.N.O.):
SLABS	100 kg/m <sup>2</sup>
RC PAD FOOTINGS	150 kg/m <sup>2</sup>
TRANSFER SLABS	200 kg/m <sup>2</sup>
PILE CAPS/RAFTS	150 kg/m <sup>2</sup>
COLUMNS	450 kg/m <sup>2</sup>
RC GROUND BEAMS	230 kg/m <sup>2</sup>
RC BEAMS	220 kg/m <sup>2</sup>
RC RET. WALLS	175 kg/m <sup>2</sup>
RC STAIRS	135 kg/m <sup>2</sup>
RC WALLS	65 kg/m <sup>2</sup>
RC BASEMENT SLABS	150 kg/m <sup>2</sup>
RC LIFT PITS	200 kg/m <sup>2</sup>
75mm SCREED	10 kg/m <sup>2</sup>

## LOADINGS

ELEMENTS:	DL	LL
FLAT ROOF	1.00 kN/m <sup>2</sup>	0.90 kN/m <sup>2</sup>
PITCHED ROOF	1.00 kN/m <sup>2</sup>	0.75 kN/m <sup>2</sup>
FLOOR	0.80 kN/m <sup>2</sup>	1.50 kN/m <sup>2</sup>
PARTITIONS/WALLS:		
INTERNAL	-	0.60 kN/m <sup>2</sup>
EXTERNAL	-	-

CONCEPT CONSULTANCY  
STRUCTURAL DESIGNERS LTD

3 Knoll House, 77 Carlton Hill - London, NW6 9XD -  
Tel: 020 76256106; Mob: 07955 919824; - e-mail: info@conceptconsultancy.eu

Client

Richard & Penelope Murley

Project

15 Lyndhurst Terrace  
LONDON, NW3 5QA

Title

STRUCTURAL NOTES  
SHEET 2

Revision	Date	Made by	Amendments
A	xx/xx/2020	GW	xx

Date	Drawn by	Checked	
20-01-2021	GW	CG	
Scales	Job No.	Drawing No.	Revision
NTS	3317	802	A



**NOTE:**  
NO MORE THEN 2 PINS TO BE LEFT INCOMPLETE AND ANY ONE TIME.

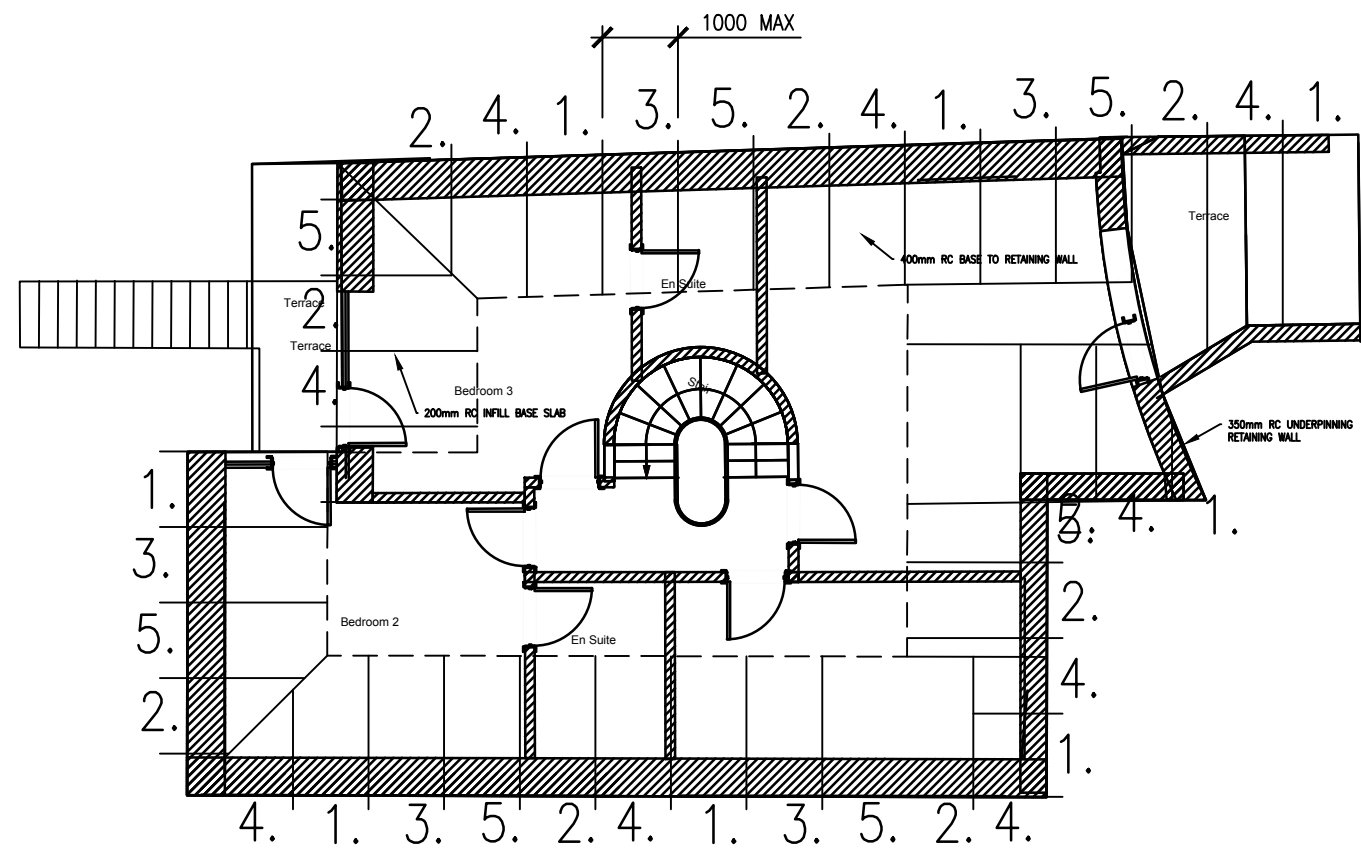

PROPOSED BASEMENT UNDERPINNING SEQUENCE PLAN

**METHOD STATEMENT FOR UNDERPINNING:**

- Underpinning to be carried out in the sequence shown, in bays 1000mm width max. Bays with the same number to be excavated simultaneously with concreting carried out immediately after exposure to avoid deterioration.
- Excavate out by hand all bays No. 1 to the depth & width specified. Ensure that ground is level, clean and rammed if necessary. Should any ground water be encountered this may be pumped out.
- Dowel bars to be inserted into surrounding ground on both sides as required to provide a key for the adjoining base section as per Detail X below.
- Pour concrete to 75mm of underside of existing wall.
- The day after concreting fill the 75mm gap with 3:1 dry pack mortar and backfill excavation.
- Excavate by hand for base of pin ensure that ground is level, clean and rammed if necessary. Should any ground water be encountered this may be pumped out.
- Pour concrete base.
- Excavation of bays No. 2 of underpinning shall not be commenced until at least 48 hours after previous bay has been dry packed.
- Continue remaining bays as per above until all underpinning is complete.
- Any discrepancy between details indicated on the drawing and those conditions actually encountered on site should be highlighted by the main contractors site supervisory personnel.
- Upon completion of all upper sections of pins. repeat steps 2 to 8 to construct lower section of pin.

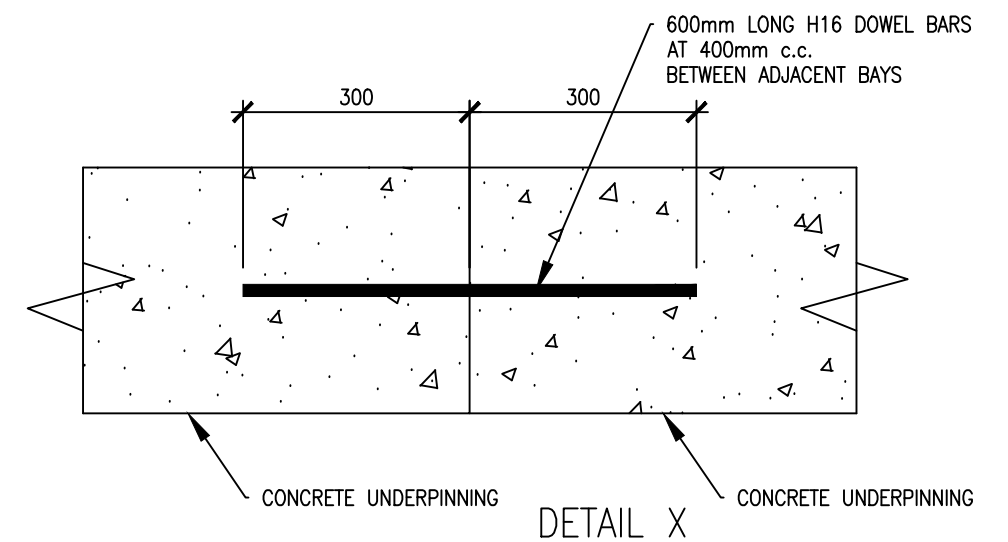

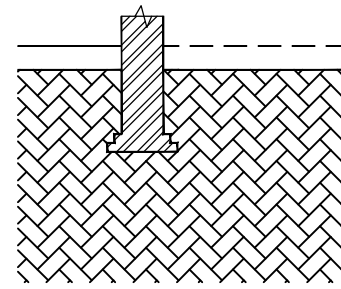

STAGE 1 - EXISTING

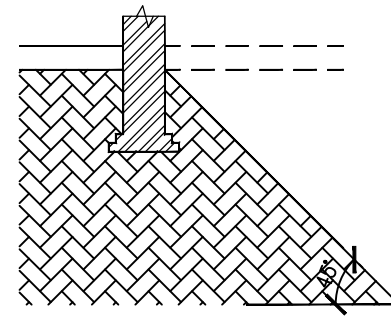

STAGE 2

20mm CEMENT BOARD

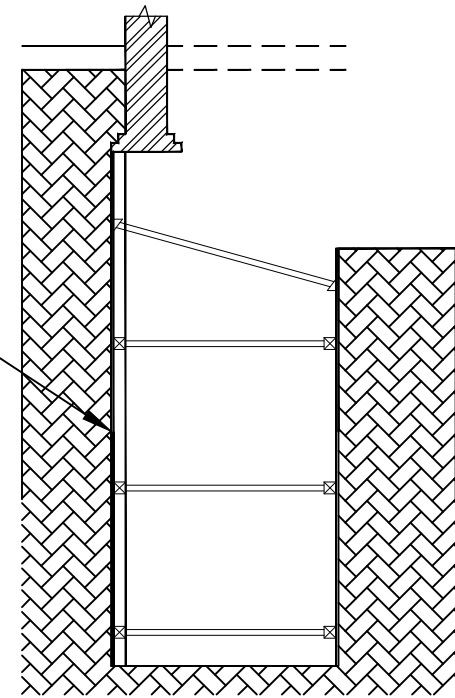

STAGE 3 - EXCAVATE FOR PIN

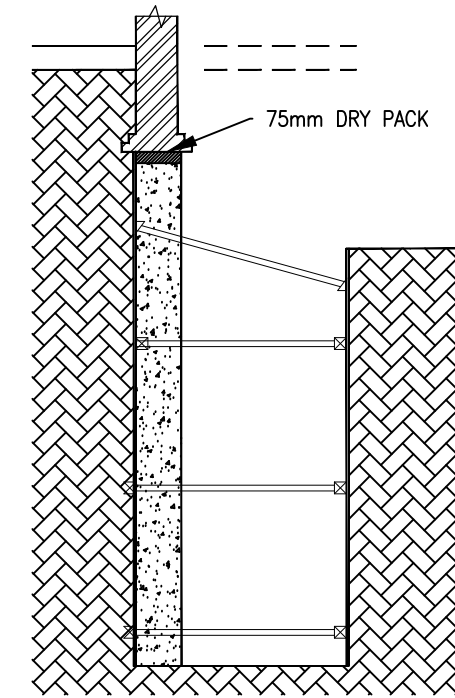

STAGE 4 - CONCRETE PIN

75mm DRY PACK

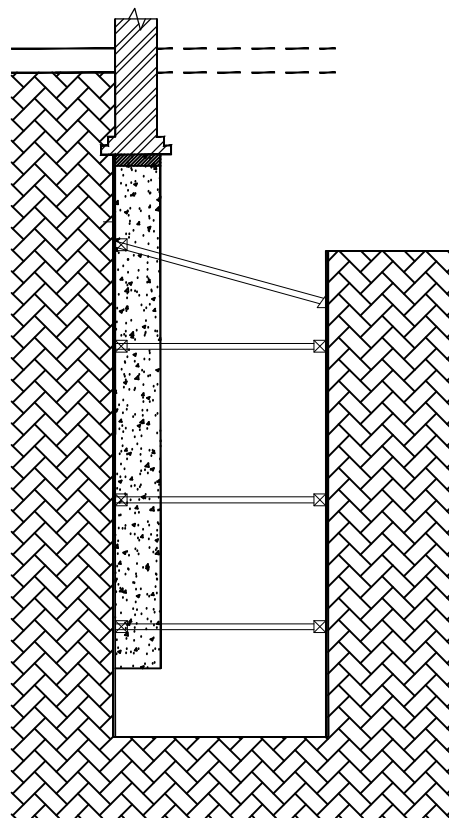

STAGE 4 - EXCAVATE FOR BASE OF PIN

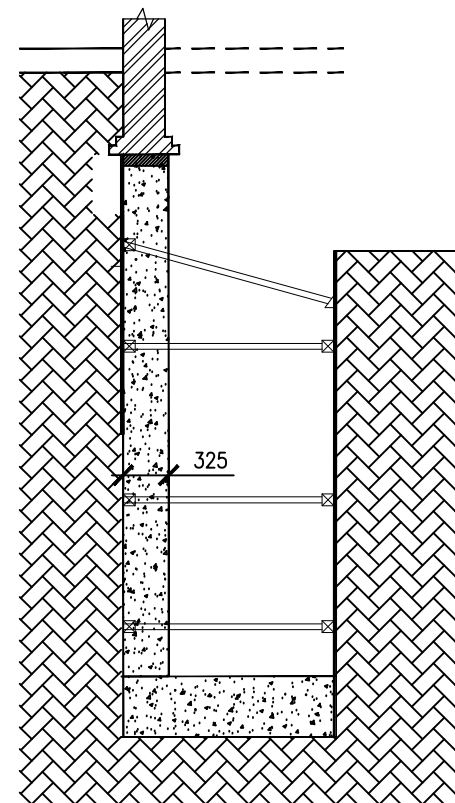

STAGE 5 - CONCRETE BASE OF PIN

325

**METHOD STATEMENT FOR BASEMENT CONSTRUCTION:**

1. Excavate for underpinning (see sequence on drawing 810), stages 1-3.
2. Install concrete underpinning (stage 4).
3. Install part of base slab (stage 5). Leaving center of basement unexcavated.
4. Install new ground floor beams to prop base of existing party walls (stage 6).
5. Reduce level of center section of basement and install temporary propping as per stage 7.
6. Complete excavation of centre section of basement (stage 8).
7. Install center section of basement floor slab (stage 8).
8. Remove temporary propping (stage 9).

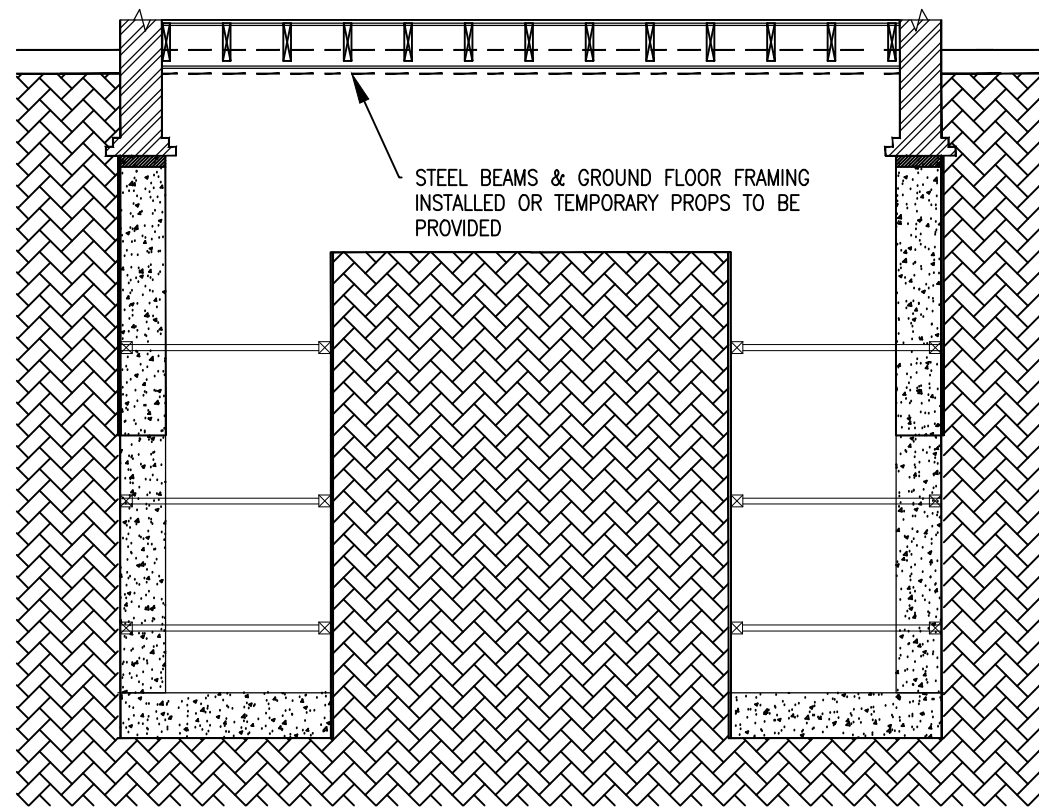

STAGE 6 - PROP UPPER SECTION

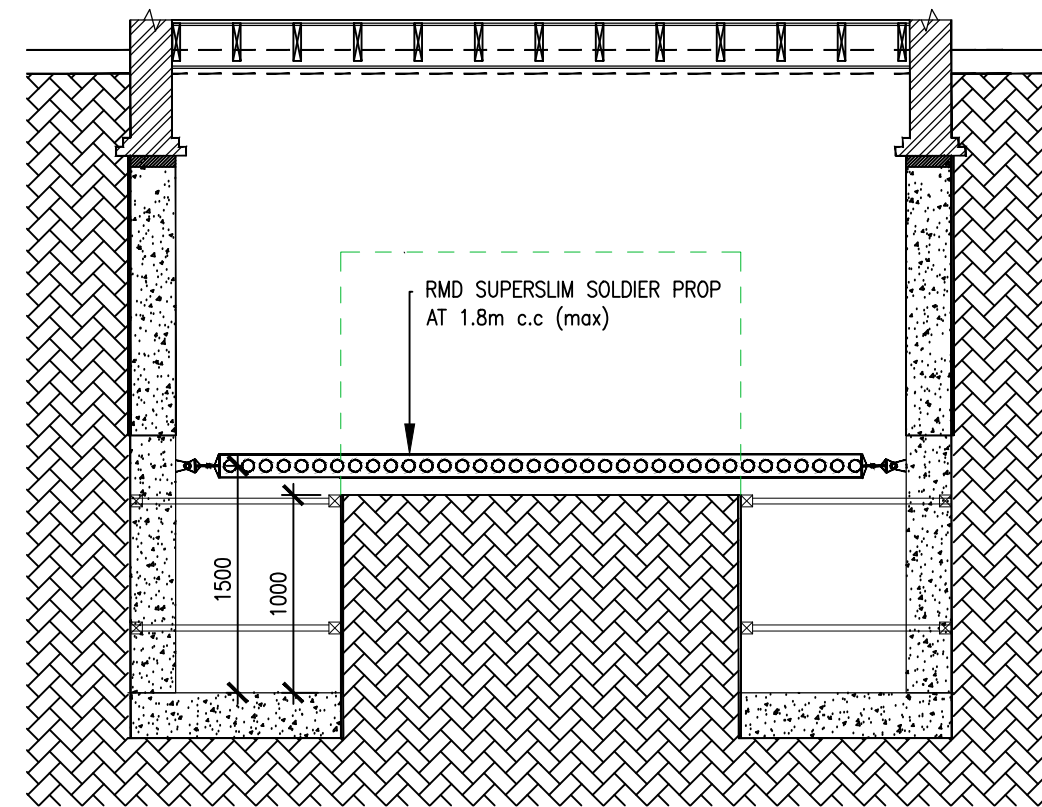

STAGE 7 - REDUCE GROUND AND INSTALL LOWER PROP

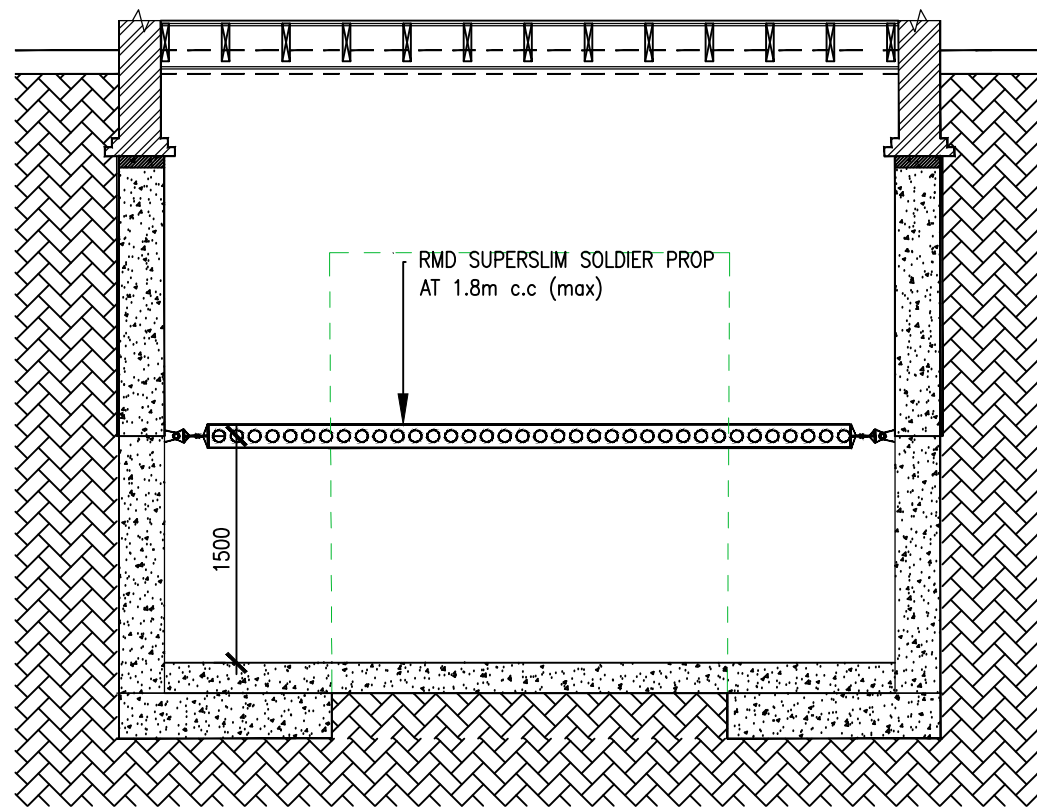

STAGE 8 - COMPLETE BASE

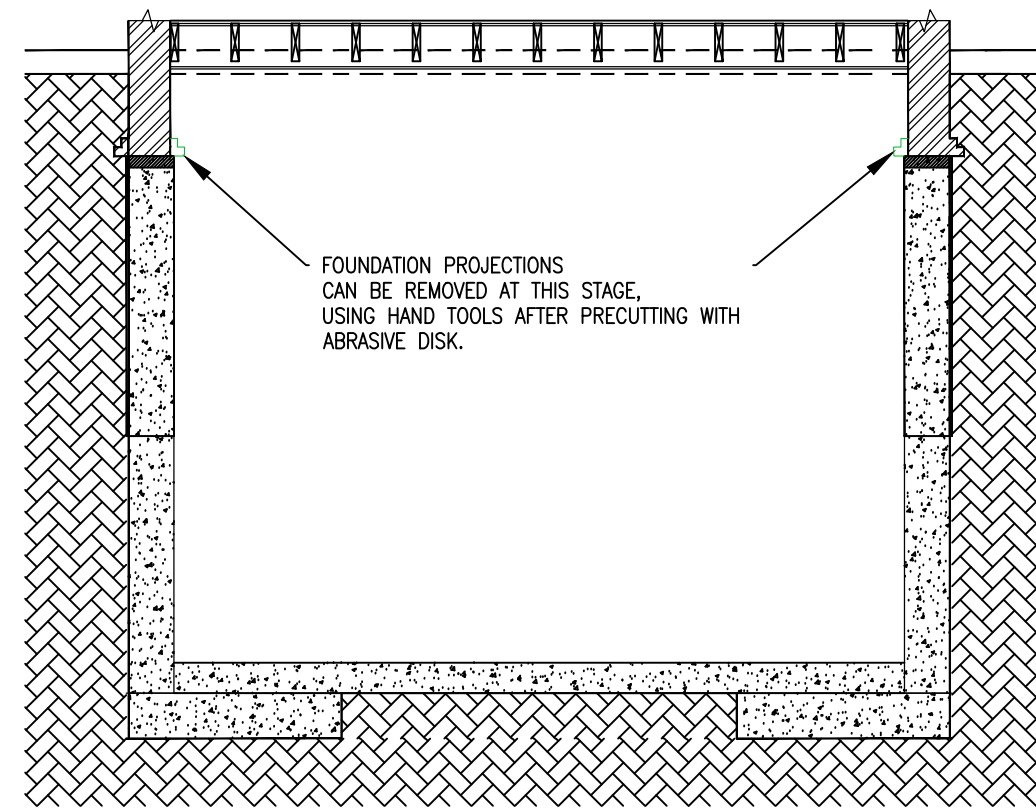

STAGE 9 - REMOVE PROPS

# Concept Consultancy

Chartered Civil & Structural Consulting Engineers

## Appendix B – Ground Investigation Report

## Appendix C – Structural Calculations

**Concept Engineering Consultancy**  
Chartered Civil & Structural Engineers  
3 Knoll House, 77 Carlton Hill, London, NW8 9XD  
Tel: 020 7625 6106

## **Calculations Cover Sheet**

**15 Lyndhurst Terrace**  
**Basement Design**

**NW3 5QA**

Rev B	July 2023
Project No.	3162

**Concept Engineering Consultancy**  
Chartered Civil & Structural Engineers  
3 Knoll House, 77 Carlton Hill, London, NW8 9XD  
Tel: 020 7625 6106

<b>Project:</b>	15 Lyndhurst Terrace	<b>Designed by:</b>	GW
<b>Project No.:</b>	3162	<b>Checked by:</b>	CG
		<b>Date:</b>	03/07/2023
<b>Subject:</b>	Contents	<b>Page:</b>	
		<b>Rev:</b>	B

**Contents**

<b>Page</b>	<b>Item</b>
1	Design Outline
2	Key Plan
3	Loading
4-5	Basement Retaining Wall

**Concept Engineering Consultancy**  
Chartered Civil & Structural Engineers  
3 Knoll House, 77 Carlton Hill, London, NW8 9XD  
Tel: 020 7625 6106

<b>Project:</b>	15 Lyndhurst Terrace	<b>Designed by:</b>	GW
<b>Project No.:</b>	3162	<b>Checked by:</b>	CG
		<b>Date:</b>	03/07/2023
<b>Subject:</b>	Design Outline	<b>Page:</b>	1
		<b>Rev:</b>	B

**Design Outline**

A new basement is to be constructed under the full footprint of the existing house. The new basement structure shall comprise of new underpin RC retaining walls with a reinforced concrete infill slab. The existing structure above shall be supported on a combination of the new underpinning retaining walls and new steel beams spanning between the new underpin retaining walls.



<b>Project:</b>	15 Lyndhurst Terrace	<b>Designed by:</b>	GW
<b>Project No.:</b>	3162	<b>Checked by:</b>	CG
<b>Subject:</b>	Key Plan	<b>Date:</b>	03/07/23
		<b>Page:</b>	2
		<b>Rev:</b>	B

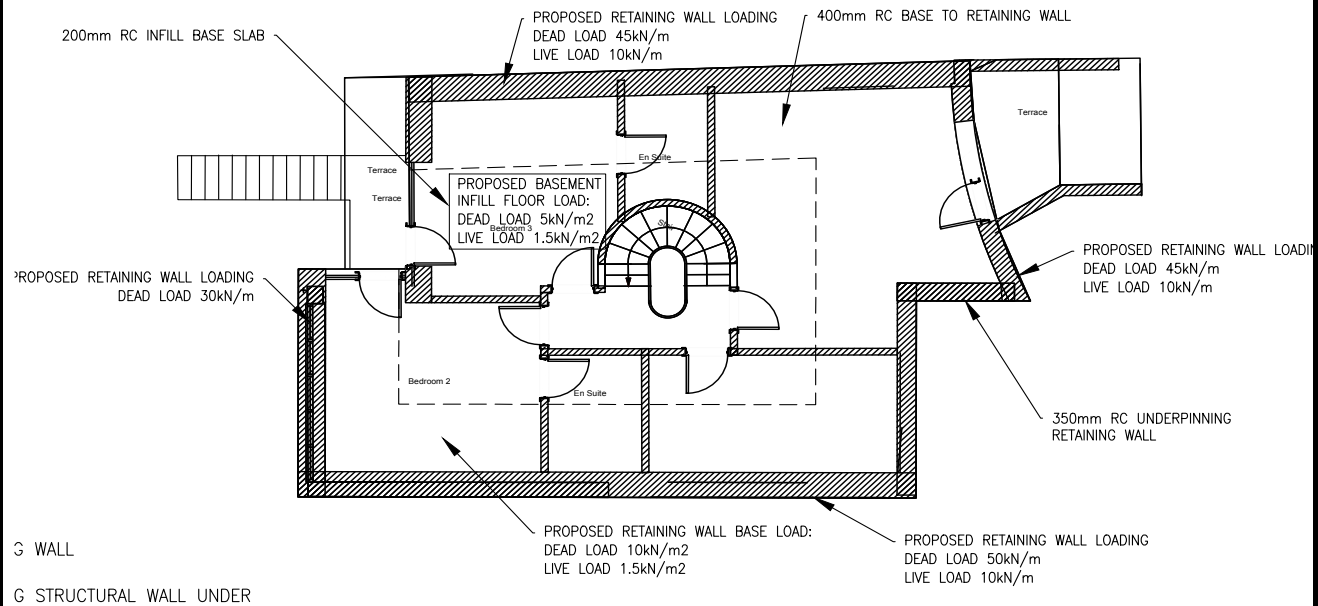

**Basement**

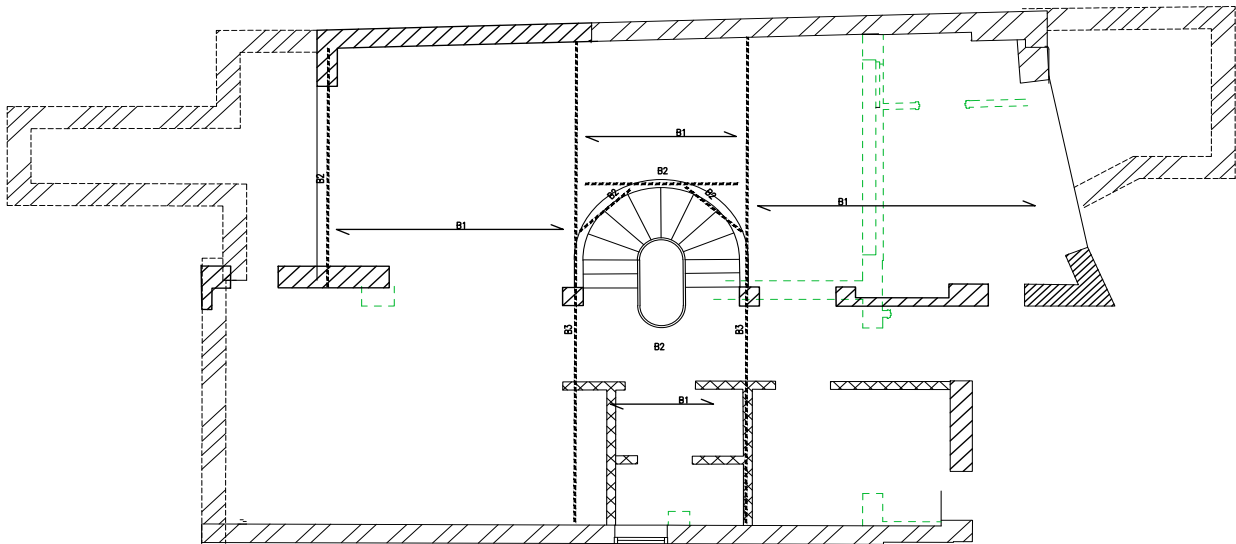

**Ground Floor**

<b>Project:</b>	15 Lyndhurst Terrace	<b>Designed by:</b>	GW
<b>Project No.:</b>	3162	<b>Checked by:</b>	CG
		<b>Date:</b>	03/07/2023
<b>Subject:</b>	Loading	<b>Page:</b>	3
		<b>Rev:</b>	B

<b><u>Floor Load</u></b>			
<b>Dead Load</b>			
Floor Boards	0.2 kN/m <sup>2</sup>		
Timber Joists	0.2 kN/m <sup>2</sup>		
Plaster Board Ceiling	0.15 kN/m <sup>2</sup>		
Insulation	0.05 kN/m <sup>2</sup>		
<b>Total</b>	<b>0.6 kN/m<sup>2</sup></b>		
<b>Live Load</b>	<b>1.5 kN/m<sup>2</sup></b>		
<b><u>Roof Loads</u></b>			
<b>Dead Load</b>			
Timber Joists	0.2 kN/m <sup>2</sup>		
Plaster Board Ceiling	0.15 kN/m <sup>2</sup>		
Insulation	0.05 kN/m <sup>2</sup>		
Ceiling Joists	0.15 kN/m <sup>2</sup>		
Roof Tiles	0.44 kN/m <sup>2</sup>		
<b>Total</b>	<b>0.99 kN/m<sup>2</sup></b>		
<b>Live Load</b>	<b>0.6 kN/m<sup>2</sup></b>		
<b><u>Roof Terrace Loads</u></b>			
<b>Dead Load</b>			
Timber Joists	0.2 kN/m <sup>2</sup>		
Plaster Board Ceiling	0.15 kN/m <sup>2</sup>		
Insulation	0.05 kN/m <sup>2</sup>		
Ceiling Joists	0.15 kN/m <sup>2</sup>		
Roof Finish	1 kN/m <sup>2</sup>		
<b>Total</b>	<b>1.55 kN/m<sup>2</sup></b>		
<b>Live Load</b>	<b>1.5 kN/m<sup>2</sup></b>		
Internal Wall	7.86 kN/m	(3m High 100mm Leaf Plastered Both Sides)	
External Wall	14.73 kN/m	(3m High 100+100 Plastered Both Sides)	

<b>Project:</b>	15 Lyndhurst Terrace	<b>Designed by:</b>	GW
<b>Project No.:</b>	3162	<b>Checked by:</b>	CG
<b>Subject:</b>	Retaining Wall at Rear	<b>Date:</b>	03/07/2023
		<b>Page:</b>	4
		<b>Rev:</b>	B

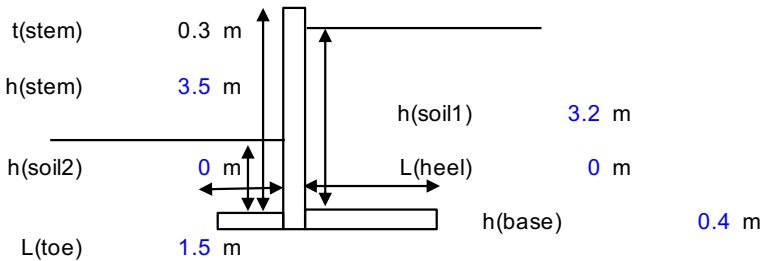

**Loading**

ka	0.5	Soil	18 kN/m <sup>2</sup>	$\gamma$ (DL)	1.35
kp	3	Surcharge	10 kN/m <sup>2</sup>	$\gamma$ (LL)	1.5

Max Lateral Force on Wall (Active) SLS = 110.92  
 Max Lateral Force on Wall (Passive) SLS = 0.58  
 kN/m  
 Max Mt on Wall Stem (Active) ULS = 155.00  
 Max Mt on Wall (Passive) ULS = 0.78  
 kNm

(Ignore Passive Resistance for ULS Design of Wall Stem) **M = 155.00**  
 kNm  
 (at base of Wall Stem) **Ved = 86.21**  
 kN/m

**RC Wall**

b	1000 mm		
h	350 mm		
Cover	50 mm		
d	282 mm	Lacer Bar Dia	10 mm
fck	25 N/mm <sup>2</sup>		
fy	500 N/mm <sup>2</sup>		

**Bending**

k	0.077965		
la	0.90		
Min Ast	0.13 %		Min Ast Req = 455 mm <sup>2</sup>
As Req = M/(0.87fyk.la.d)			Ast Req = 1398 mm <sup>2</sup>
Provide	T16 @	125 c.c	
As Prov	1608 mm <sup>2</sup> /m	ok	

<b>Project:</b>	15 Lyndhurst Terrace	<b>Designed by:</b>	GW
<b>Project No.:</b>	3162	<b>Checked by:</b>	CG
<b>Subject:</b>	Retaining Wall at Rear	<b>Date:</b>	03/07/2023
		<b>Page:</b>	
		<b>Rev:</b>	B

	<p><b>Shear</b></p> $V_{rd,c} = (0.12k \cdot (100p_1 \cdot f_{ck})^{0.33}) \cdot b \cdot d$ <p>k = 2  p1 = 0.01</p> $V_{rd,c} = 149.8 \text{ kN}$ $V_{rd,c}(\text{min}) = (0.035k^{3/2} \cdot f_{ck}^{0.5}) \cdot b \cdot d$ $V_{rd,c}(\text{min}) = 123.4 \text{ kN}$ <p><b><u>Ved &lt; Vrd,c No Shear Reinf Required</u></b></p>													
EN 1997-1	<p><b>Stability of Wall</b></p> <p>Partial Factors of Safety (<math>\gamma_f</math>)</p> <table style="width: 100%;"> <tr> <td colspan="2"><i>Permanent Load:</i></td> <td colspan="2"><i>Variable Load:</i></td> </tr> <tr> <td>Unfavourable</td> <td>1.1</td> <td>Unfavourable</td> <td>1.5</td> </tr> <tr> <td>Favourable</td> <td>0.9</td> <td>Favourable</td> <td>0</td> </tr> </table> <p>Tan <math>\phi</math> = 0.5</p> <p><b>For EQU Stability (Overturning)</b></p> <p>Unfavourable Actions = <math>\gamma_f \cdot P_{soil} + \gamma_f \cdot LL</math> <span style="float: right;">136.05 kNm/m</span></p> <p>Favourable Actions = <math>\gamma_f \cdot P_{wall} + \gamma_f \cdot P_{base}</math> <span style="float: right;">53.56 kNm/m</span></p> <p>(Note <math>\gamma_f</math> for Soil Weight Density = 1.0 as per Table A.2 BS EN 1997) <span style="float: right;">OK</span></p> <p><b>For EQU Stability (Sliding)</b></p> <p>Unfavourable Actions = <math>\gamma_f \cdot P_{soil} + \gamma_f \cdot LL</math> <span style="float: right;">91.15 kN/m</span></p> <p>Favourable Actions = <math>(\gamma_f \cdot P_{wall} + \gamma_f \cdot P_{base}) \cdot \tan \phi + \gamma_f \cdot P_{passive}</math> <span style="float: right;">23.80 kN/m</span></p> <p><b><u>Base Proped No Sliding!</u></b></p>	<i>Permanent Load:</i>		<i>Variable Load:</i>		Unfavourable	1.1	Unfavourable	1.5	Favourable	0.9	Favourable	0	
<i>Permanent Load:</i>		<i>Variable Load:</i>												
Unfavourable	1.1	Unfavourable	1.5											
Favourable	0.9	Favourable	0											