

<b>Existing Door - ED01</b>
<b>Location - Hallway</b>
<b>Structural Opening - 810 x 2070mm</b>
<b>Type - Exterior Door</b>
<b>Finish - Timber with white paint</b>
<b>Glazing - Single</b>
<b>Quantity - 1</b>

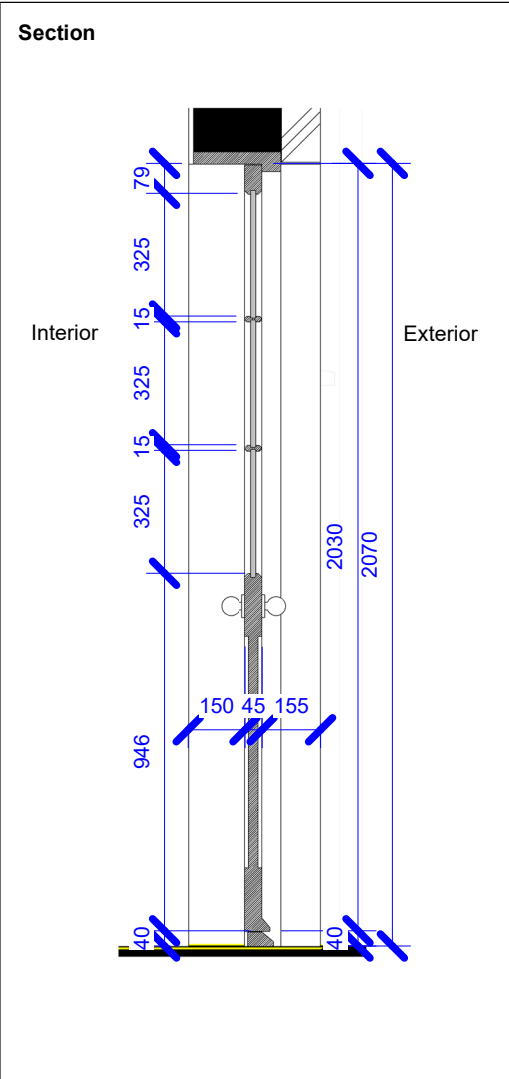
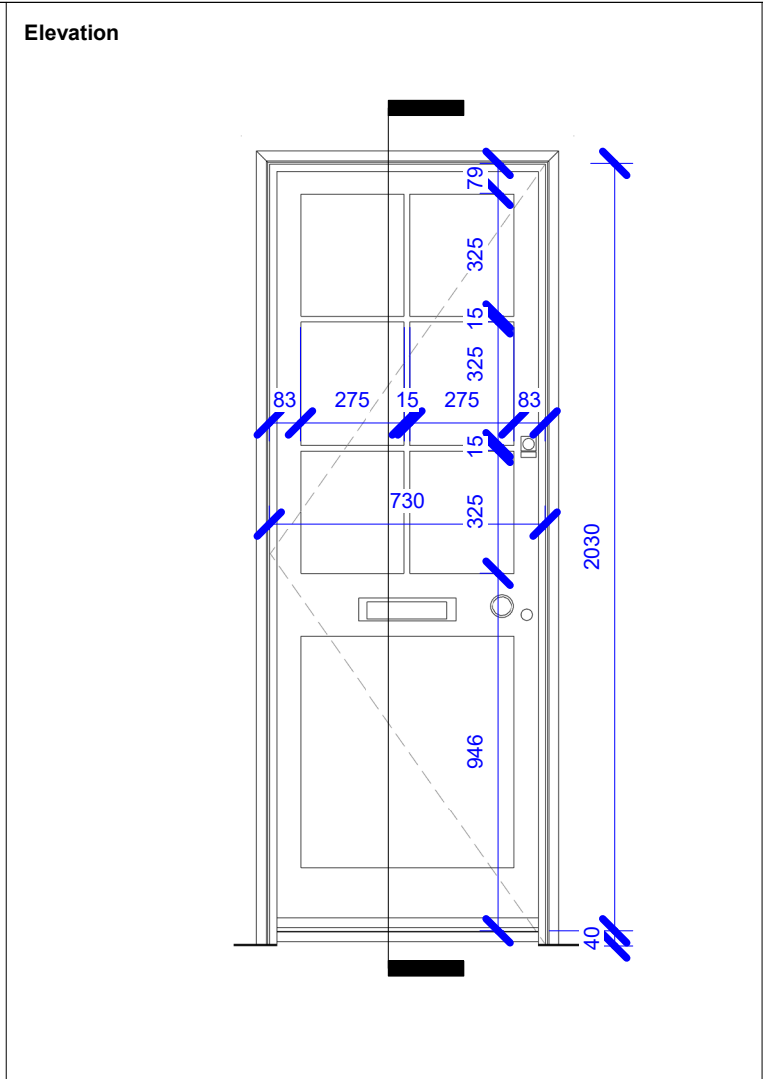
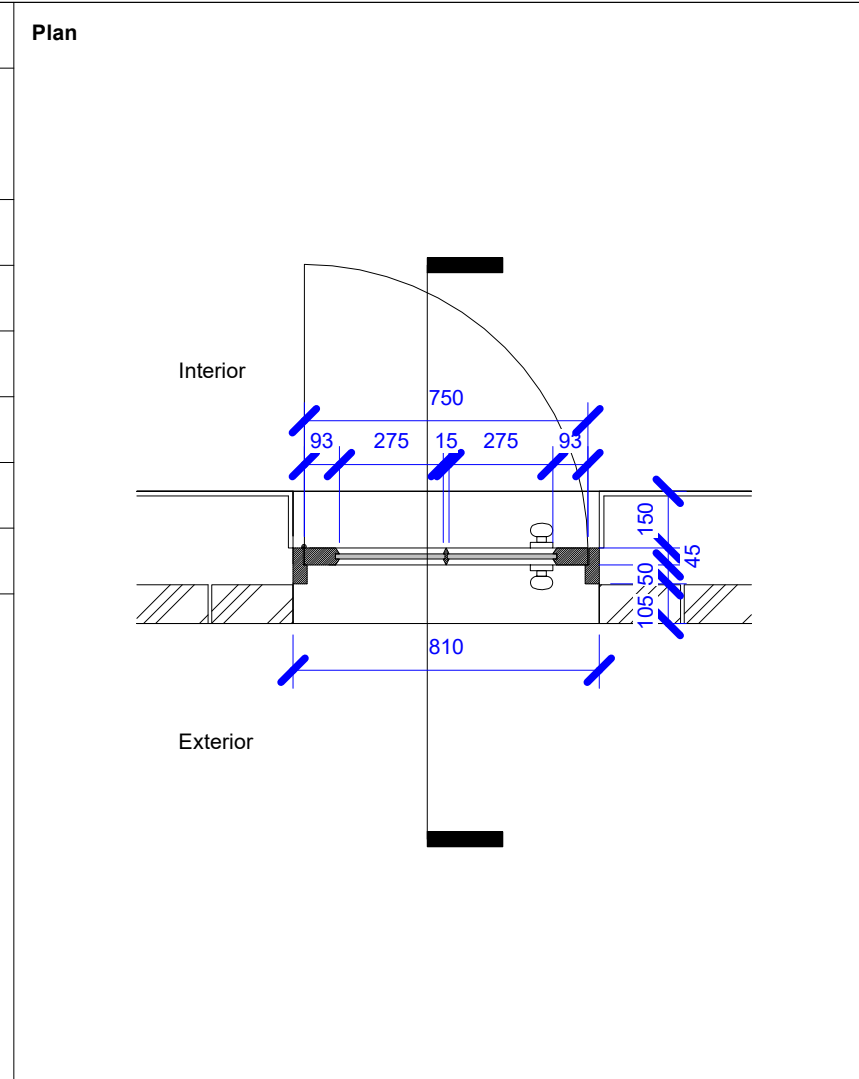

**general notes**

- This drawing is copyright In Situ Architects and must not be copied in whole or part without prior consent.
- Do not scale from this drawing.
- Refer to drawing number.
- This drawing is to be read in conjunction with all other relevant architects and engineer's drawings.
- All dimensions to be checked on site prior to commencement of works and any discrepancies are to be checked with the architect immediately.
- Unless otherwise stated all dimensions are in mm.
- Not for construction

<b>Existing Window - ED02</b>
<b>Location - Kitchen</b>
<b>Structural Opening - 810 x 2000mm</b>
<b>Type - External Door</b>
<b>Finish - Timber with white paint</b>
<b>Glazing - Single</b>
<b>Quantity - 1</b>

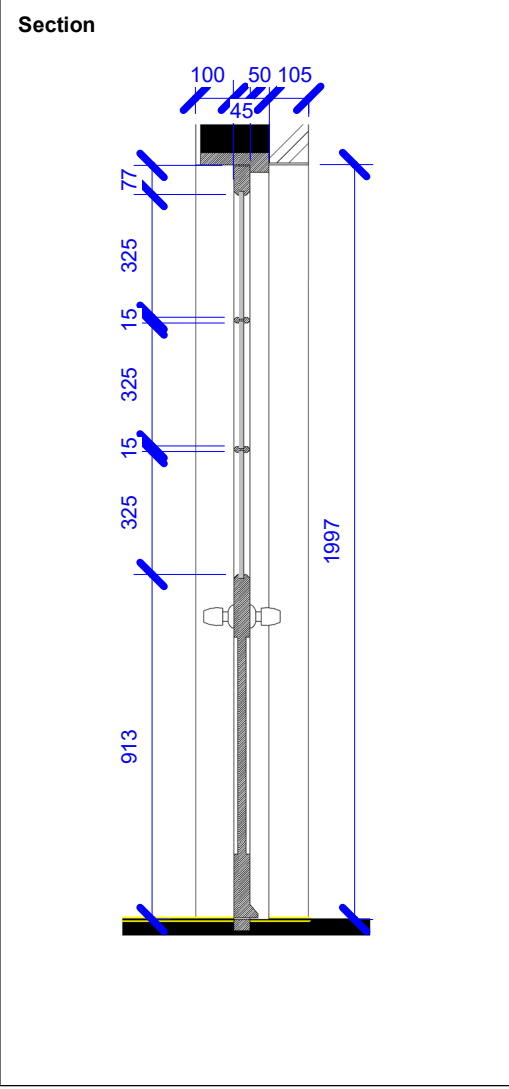
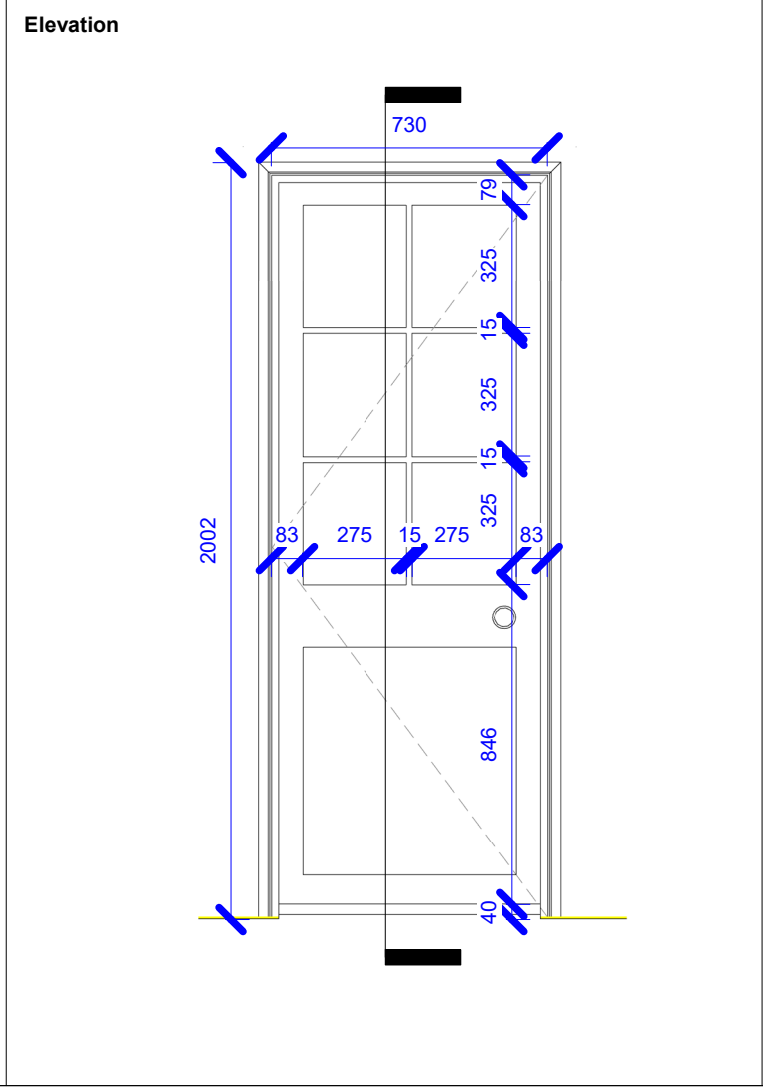
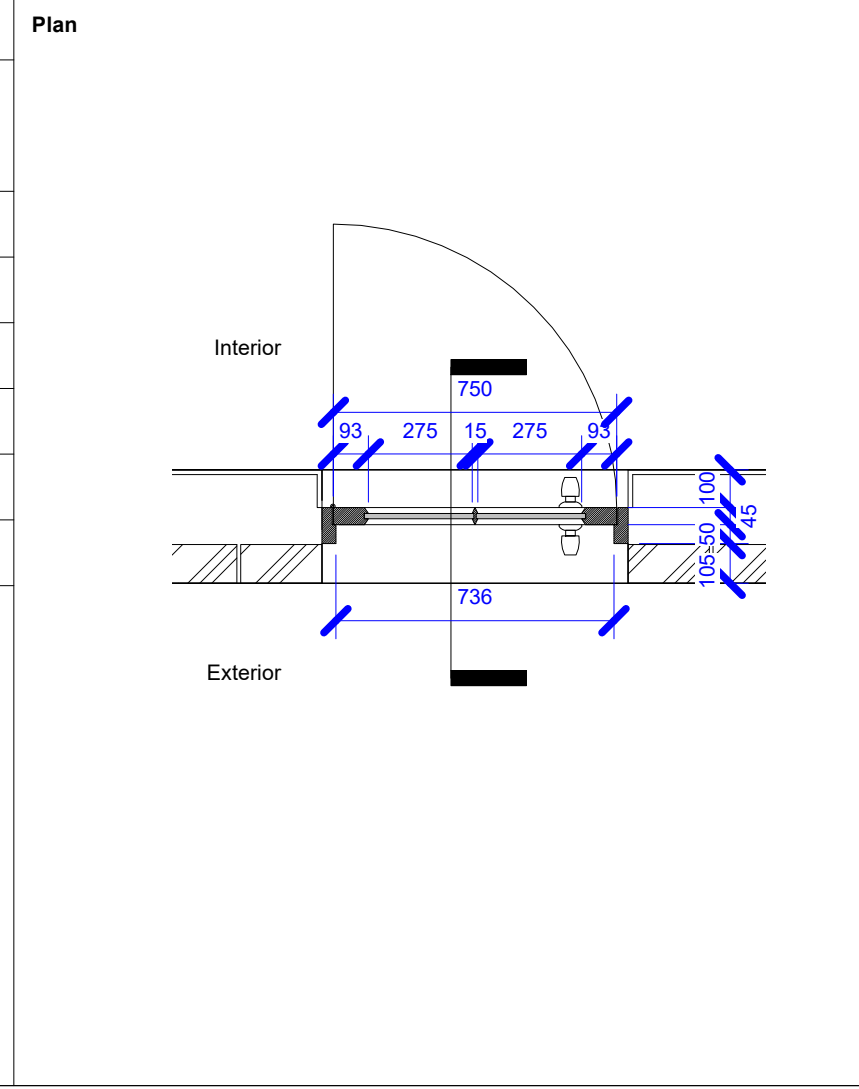

rev	date	description	dw

client **Jack and Helene Reardon Bond**

project **7a Bartholomew Rd**

status

drawing title **Existing Door Details**

drawing no **IS\_A\_0507**  
project no - originator - volume - level - type - role - number

scale **1 : 20**      **06/06/23**      **SK**

original **A3**      **SB**

**IN SITU**  
 address **39 Eric Street, London, E3 4TG**  
 telephone **+44 (0)777 276 0270**  
 email **simon.insitu@gmail.com**  
 website **www.insitulondon.com**