

Front (sign face) view

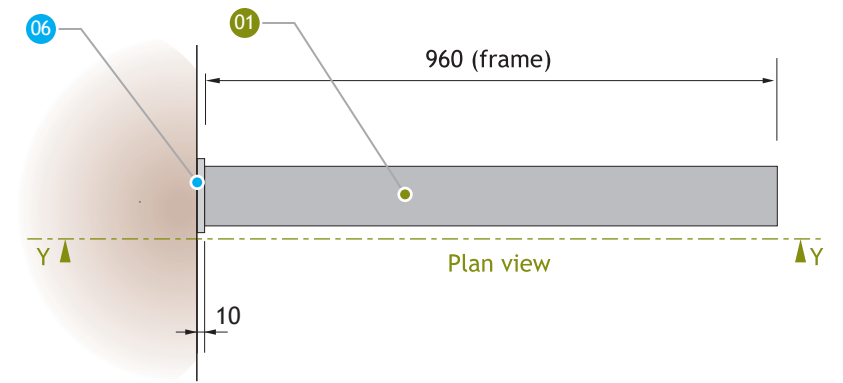

Plan view

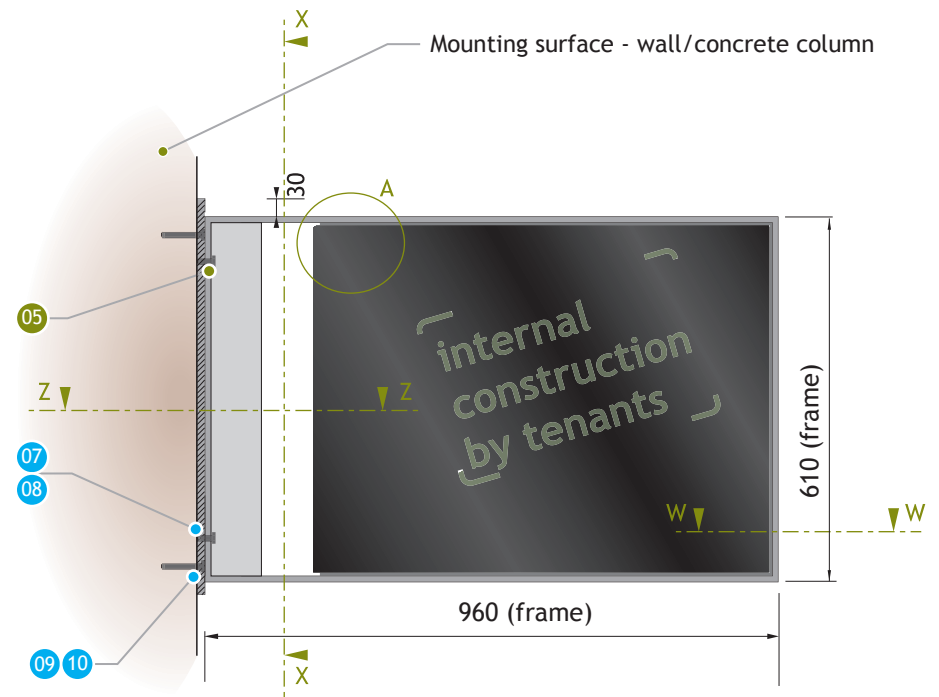

Section through column and sign frame (Y-Y)

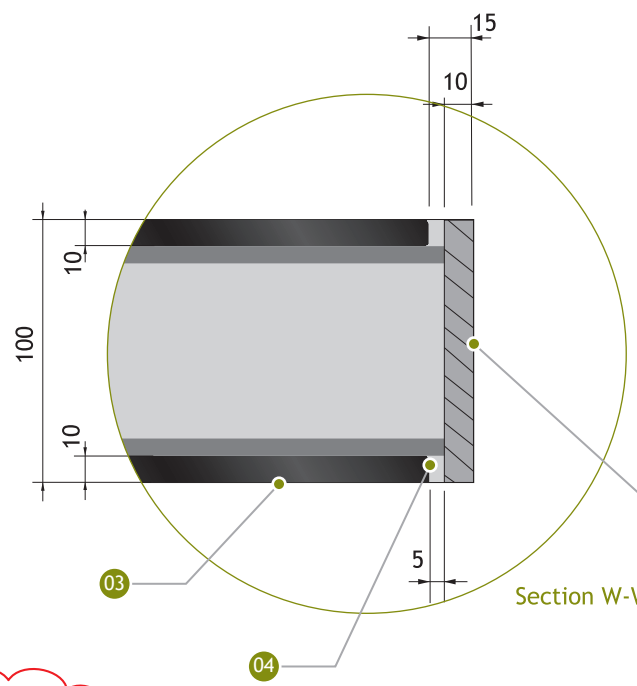

Section W-W

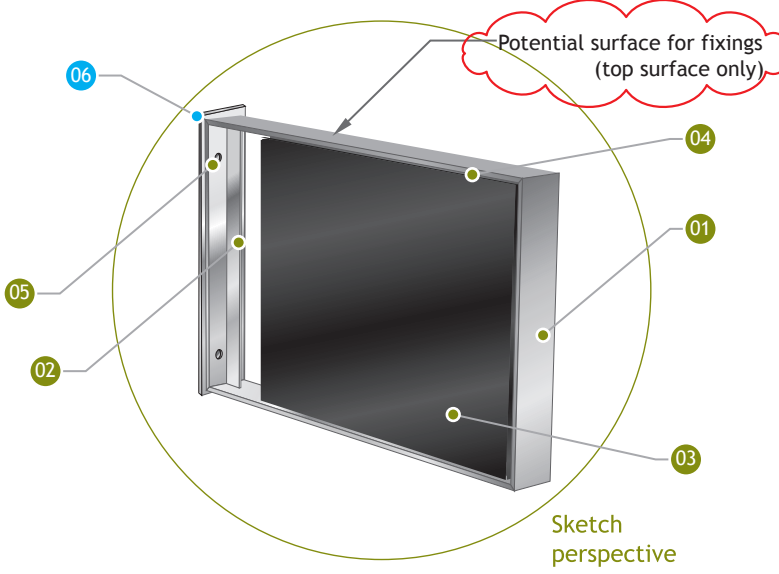

Sketch perspective

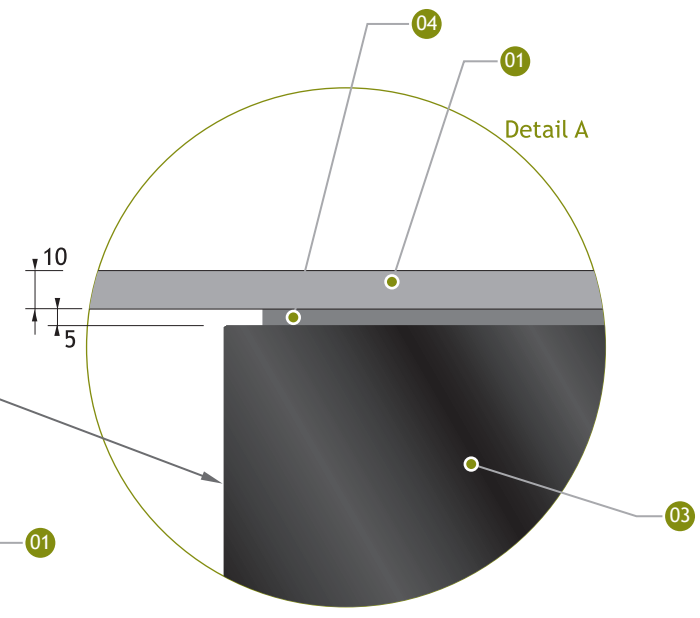

Detail A

No fixings permissible on visible surfaces

Preferred surface for fixings (vertical surface facing wall)

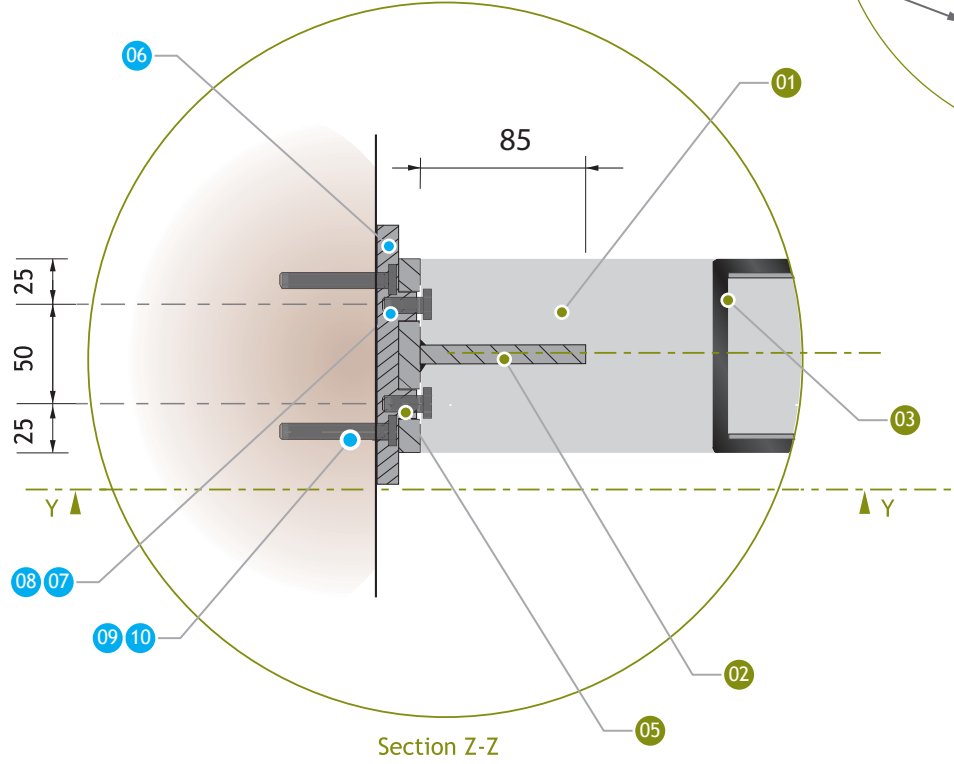

Section Z-Z

- BY TENANT:**
- 12mm thick stove-enamelled internal sign frame to RAL 7044. Incorporates 4 qty fixing holes (item 5) for mounting to columns.
 - Strengthening web welded to vertical mounting face of frame and internal faces at top and bottom edges, 10mm thick
 - Removable face panels with folded returns (max. r2). Faces and returns of sign panels to be painted. Returns to be 10mm except at internal return/face adjacent to column fixings, where return(combined)/face is 100mm
 - 10mm deep shadow gap between frame and face panels. Rear of shadow gap to be painted to match frame (RAL 7044)
 - 4 qty. oversized holes (dia. 16mm) in sign frame, to provide clearance holes for fixings (item 8)

- BY LANDLORD:**
- 12mm thick mounting plate, stove enamelled to RAL 7044 with threaded holes (item 7) and counterbored clearance holes (item 9). See BR1-VPD-T002b for more details
 - 4 qty. M12 threaded through holes for sign fixing bolts
 - 4 qty. M12 x 24 hex head bolts (with washers as necessary) to secure sign onto mounting plate, painted RAL 7044
 - Counterbored holes to take chosen fixings for mounting plate to wall. Counterbore to allow fixing head to sit below surface of plate
 - 4 qty. fixings to secure sign to wall - specification to be defined by Landlord's installer. Fixing heads to be shallow enough (eg. socket button head) to sit within counterbored hole (item 9). Fixings and fixing holes to be hidden when sign installed.
 - Existing wall.

GENERAL NOTES:
Sign to be non-illuminated

Drawing to be read in conjunction with VPD-T002b and VPD-T002v
Refer to LBA and trade contractor drawings for mounting plate production dimensions, tolerances and details

Tenants nominated contractor to check dimensions and tolerances of installed mounting plates prior to production.

Individual Tenant signs must conform with this specification. Any variations require prior written agreement with the Landlord

Artwork/graphic layouts to be approved by Landlord

Maximum sign weight 39kg

Tenant (or their nominated supplier/installer) to use appropriate shims/spacers to ensure signs are level and true when installed.

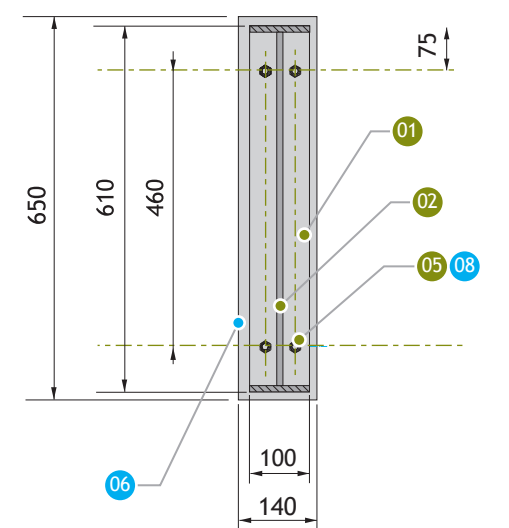

Section through sign frame/ bracket (X-X)