

Ordnance Survey, (c) Crown Copyright 2023. All rights reserved. Licence number 100022432

REV.	DATE	DESCRIPTION	REV.	DATE	DESCRIPTION
-	19.05.2023	PLANNING ISSUE			

**NOTES:**

- ALL DIMENSIONS IN MM UNLESS OTHERWISE STATED
- THIS DRAWING IS TO BE READ IN CONJUNCTION WITH ALL RELEVANT CONTRACT DOCUMENTS
- THIS DRAWING IS TO BE READ IN CONJUNCTION WITH ALL ENGINEER'S DRAWINGS
- DO NOT SCALE FROM THIS DRAWING
- REPORT ANY ERRORS, CONTRADICTIONS, & OMISSIONS TO THE ARCHITECT AS SOON AS POSSIBLE
- WHEN THIS DRAWING IS ISSUED IN DWG FORMAT IT IS AN UNCONTROLLED VERSION ISSUED TO ENABLE THE RECIPIENT TO PREPARE THEIR OWN DRAWINGS FOR WHICH THEY ARE SOLELY RESPONSIBLE. IT IS BASED ON BACKGROUND INFORMATION CURRENT AT TIME OF ISSUE. BEN ADAMS ARCHITECTS ACCEPTS NO LIABILITY FOR ANY SUCH ALTERATIONS OR ADDITIONS TO OR DISCREPANCIES ARISING OUT OF CHANGES TO SUCH BACKGROUND INFORMATION WHICH OCCUR AFTER IT IS ISSUED BY BEN ADAMS ARCHITECTS.

**KEY**

- BOROUGH BOUNDARY
- SITE BOUNDARY

**Scale Bar**

0 10M 50M

N

**Ben Adams Architects**

Third Floor  
97 Southbank Street  
London SE1 0UP

T 020 7633 0000  
ben@benadamsarchitects.co.uk  
info@benadamsarchitects.co.uk

**DRAWING NAME:** SITE LOCATION PLAN

**PROJECT NAME:** DRURY LANE - MRP

**DRAWING NO:** P001/-

**JOB NO:** 22-034

**SCALE:** 1:1250 @ A3

**STAGE:** PLANNING

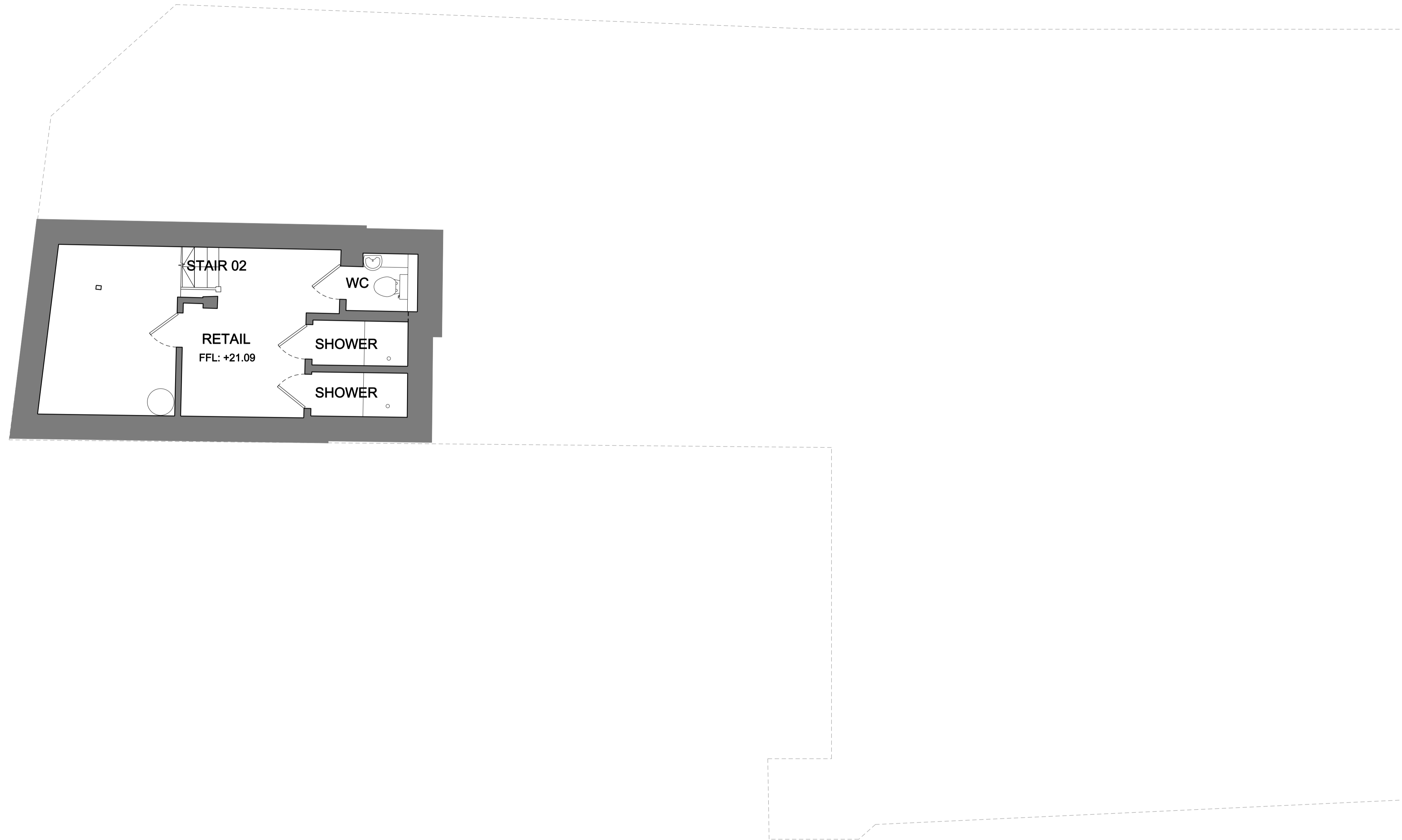



REV.	DATE	DESCRIPTION	REV.	DATE	DESCRIPTION
-	19.05.2023	PLANNING ISSUE			

**NOTES:**

1. ALL DIMENSIONS IN MM UNLESS OTHERWISE STATED
2. THIS DRAWING IS TO BE READ IN CONJUNCTION WITH ALL RELEVANT CONTRACT DOCUMENTS
3. THIS DRAWING IS TO BE READ IN CONJUNCTION WITH ALL ENGINEER'S DRAWINGS
4. DO NOT SCALE FROM THIS DRAWING
5. REPORT ANY ERRORS, CONTRADICTIONS, & OMISSIONS TO THE ARCHITECT AS SOON AS POSSIBLE
6. WHEN THIS DRAWING IS ISSUED IN DWG FORMAT IT IS AN UNCONTROLLED VERSION ISSUED TO ENABLE THE RECIPIENT TO PREPARE THEIR OWN DRAWINGS FOR WHICH THEY ARE SOLELY RESPONSIBLE. IT IS BASED ON BACKGROUND INFORMATION CURRENT AT TIME OF ISSUE. BEN ADAMS ARCHITECTS ACCEPTS NO LIABILITY FOR ANY SUCH ALTERATIONS OR ADDITIONS TO OR DISCREPANCIES ARISING OUT OF CHANGES TO SUCH BACKGROUND INFORMATION WHICH OCCUR AFTER IT IS ISSUED BY BEN ADAMS ARCHITECTS.

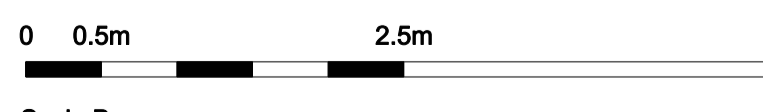
**KEY:**



 EXISTING WALLS

**Ben Adams Architects**

Third Floor  
 17 Southpark Street  
 London SE1 0UP

T 020 7633 0000  
 ben@benadamsarchitects.co.uk  
 info@benadamsarchitects.co.uk

**JOB NO:** 22-034  
**SCALE:** 1:100 @ A3 1:50 @ A1  
**STAGE:** PLANNING

**DRAWING NAME:** EXISTING BASEMENT FLOOR PLAN

**PROJECT NAME:** DRURY LANE - MRP

**DRAWING NO:** P099/-

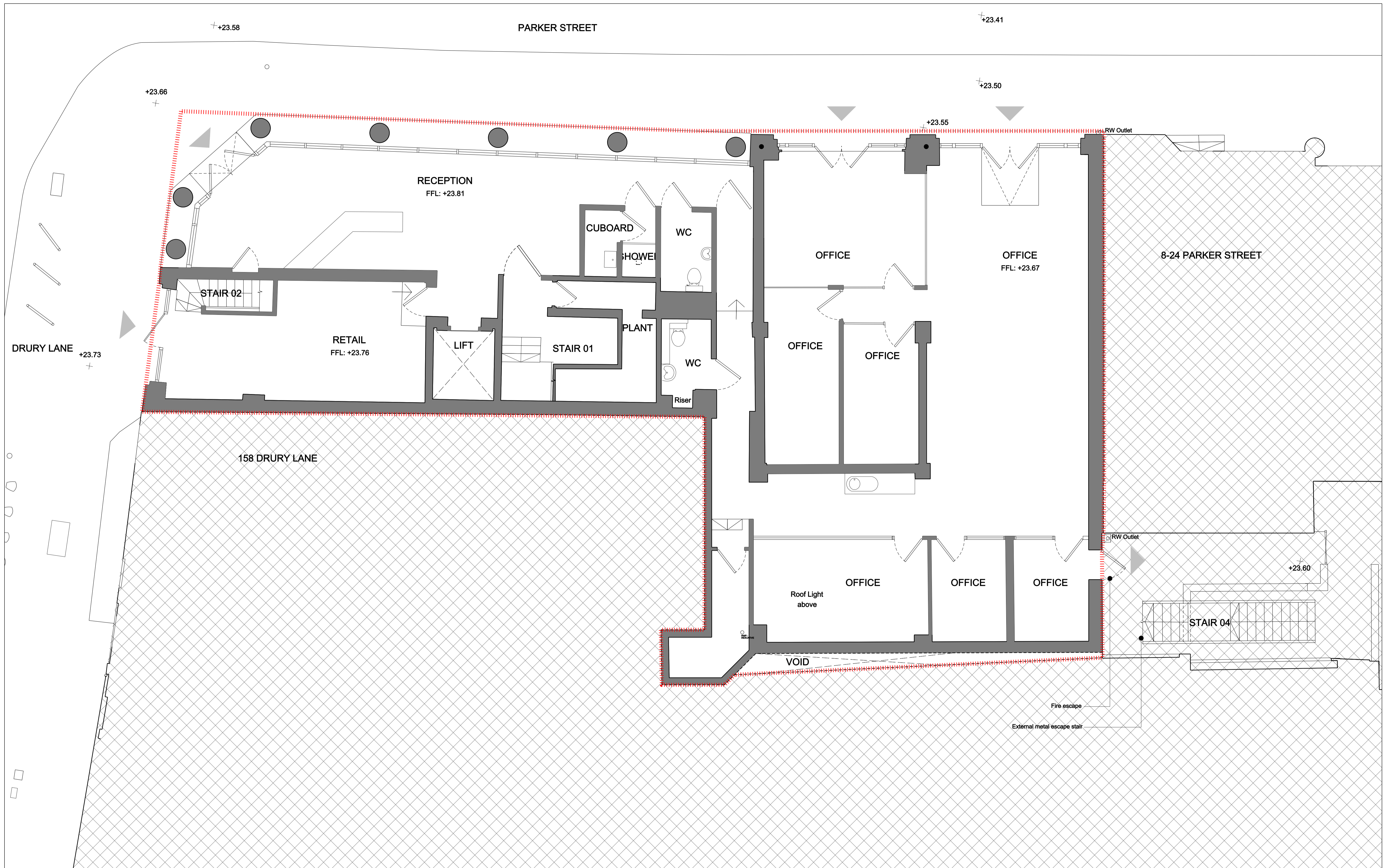

REV.	DATE	DESCRIPTION
-	19.05.2023	PLANNING ISSUE

REV.	DATE	DESCRIPTION

**NOTES:**

- ALL DIMENSIONS IN MM UNLESS OTHERWISE STATED
- THIS DRAWING IS TO BE READ IN CONJUNCTION WITH ALL RELEVANT CONTRACT DOCUMENTS
- THIS DRAWING IS TO BE READ IN CONJUNCTION WITH ALL ENGINEER'S DRAWINGS
- DO NOT SCALE FROM THIS DRAWING
- REPORT ANY ERRORS, CONTRADICTIONS, & OMISSIONS TO THE ARCHITECT AS SOON AS POSSIBLE
- WHEN THIS DRAWING IS ISSUED IN DWG FORMAT IT IS AN UNCONTROLLED VERSION ISSUED TO ENABLE THE RECIPIENT TO PREPARE THEIR OWN DRAWINGS FOR WHICH THEY ARE SOLELY RESPONSIBLE. IT IS BASED ON BACKGROUND INFORMATION CURRENT AT TIME OF ISSUE.
- BEN ADAMS ARCHITECTS ACCEPTS NO LIABILITY FOR ANY SUCH ALTERATIONS OR ADDITIONS TO OR DISCREPANCIES ARISING OUT OF CHANGES TO SUCH BACKGROUND INFORMATION WHICH OCCUR AFTER IT IS ISSUED BY BEN ADAMS ARCHITECTS.

**KEY:**

0 0.5m 2.5m 5m

Scale Bar

EXISTING WALLS

APPLICATION BOUNDARY

**Ben Adams Architects**

Third Floor  
19 Southpark Street  
London SE1 0UP

T 020 7633 0000  
ben@benadamsarchitects.co.uk  
info@benadamsarchitects.co.uk

**DRAWING NAME:** EXISTING GROUND FLOOR PLAN

**PROJECT NAME:** DRURY LANE - MRP

**DRAWING NO:** P100/-

**JOB NO:** 22-034

**SCALE:** 1:100 @ A3 1:50 @ A1

**STAGE:** PLANNING

PARKER STREET

DRURY LANE

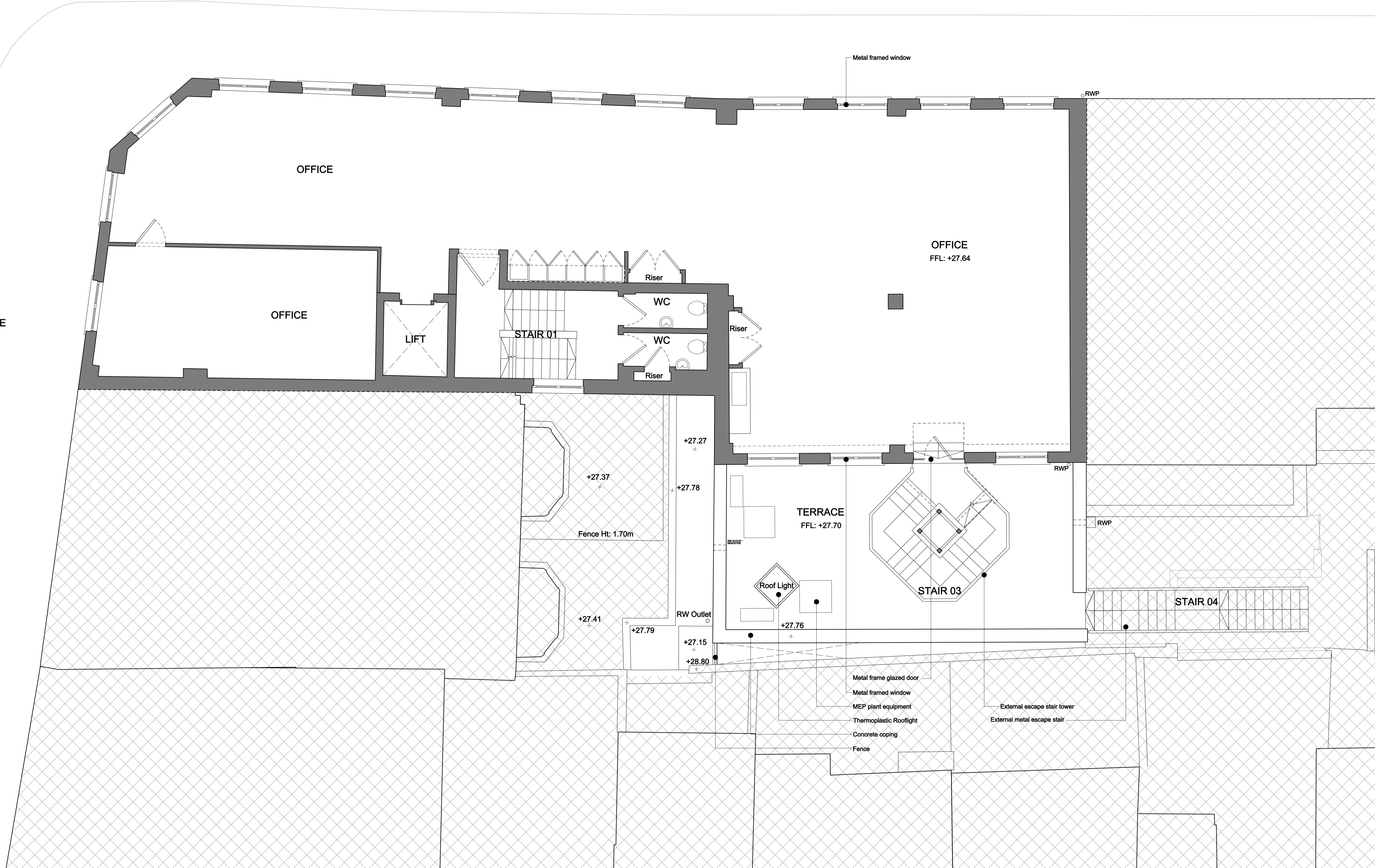

REV.	DATE	DESCRIPTION	REV.	DATE	DESCRIPTION
-	19.05.2023	PLANNING ISSUE			

**NOTES:**

1. ALL DIMENSIONS IN MM UNLESS OTHERWISE STATED
2. THIS DRAWING IS TO BE READ IN CONJUNCTION WITH ALL RELEVANT CONTRACT DOCUMENTS
3. THIS DRAWING IS TO BE READ IN CONJUNCTION WITH ALL ENGINEER'S DRAWINGS
4. DO NOT SCALE FROM THIS DRAWING
5. REPORT ANY ERRORS, CONTRADICTIONS, & OMISSIONS TO THE ARCHITECT AS SOON AS POSSIBLE
6. WHEN THIS DRAWING IS ISSUED IN DWG FORMAT IT IS AN UNCONTROLLED VERSION ISSUED TO ENABLE THE RECIPIENT TO PREPARE THEIR OWN DRAWINGS FOR WHICH THEY ARE SOLELY RESPONSIBLE. IT IS BASED ON BACKGROUND INFORMATION CURRENT AT TIME OF ISSUE. BEN ADAMS ARCHITECTS ACCEPTS NO LIABILITY FOR ANY SUCH ALTERATIONS OR ADDITIONS TO OR DISCREPANCIES ARISING OUT OF CHANGES TO SUCH BACKGROUND INFORMATION WHICH OCCUR AFTER IT IS ISSUED BY BEN ADAMS ARCHITECTS.

**KEY:**

0 0.5m 2.5m 5m ■ EXISTING WALLS

Scale Bar

**Ben Adams Architects**

Third Floor  
29 Southpark Street  
London SE1 0UP

T 020 7633 0000  
ben@benadamsarchitects.co.uk  
info@benadamsarchitects.co.uk

**DRAWING NAME:** EXISTING FIRST FLOOR PLAN

**PROJECT NAME:** DRURY LANE - MRP

**DRAWING NO:** P101/-

**JOB NO:** 22-034

**SCALE:** 1:100 @ A3 1:50 @ A1

**STAGE:** PLANNING

PARKER STREET

DRURY LANE

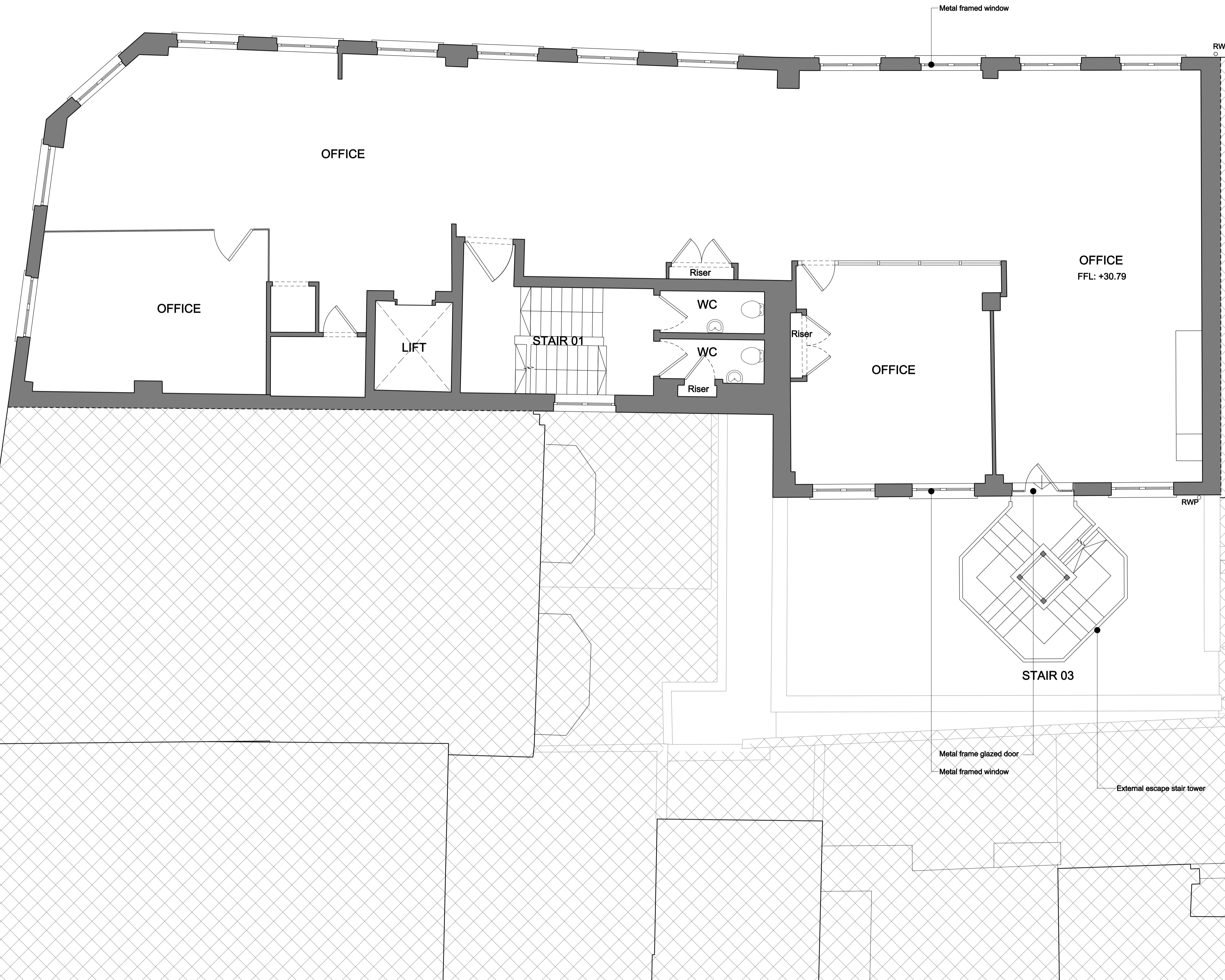

REV.	DATE	DESCRIPTION	REV.	DATE	DESCRIPTION
-	19.05.2023	PLANNING ISSUE			

**NOTES:**

1. ALL DIMENSIONS IN MM UNLESS OTHERWISE STATED
2. THIS DRAWING IS TO BE READ IN CONJUNCTION WITH ALL RELEVANT CONTRACT DOCUMENTS
3. THIS DRAWING IS TO BE READ IN CONJUNCTION WITH ALL ENGINEER'S DRAWINGS
4. DO NOT SCALE FROM THIS DRAWING
5. REPORT ANY ERRORS, CONTRADICTIONS, & OMISSIONS TO THE ARCHITECT AS SOON AS POSSIBLE
6. WHEN THIS DRAWING IS ISSUED IN DWG FORMAT IT IS AN UNCONTROLLED VERSION ISSUED TO ENABLE THE RECIPIENT TO PREPARE THEIR OWN DRAWINGS FOR WHICH THEY ARE SOLELY RESPONSIBLE. IT IS BASED ON BACKGROUND INFORMATION CURRENT AT TIME OF ISSUE. BEN ADAMS ARCHITECTS ACCEPTS NO LIABILITY FOR ANY SUCH ALTERATIONS OR ADDITIONS TO OR DISCREPANCIES ARISING OUT OF CHANGES TO SUCH BACKGROUND INFORMATION WHICH OCCUR AFTER IT IS ISSUED BY BEN ADAMS ARCHITECTS.

**KEY:**

0 0.5m 2.5m 5m ■ EXISTING WALLS

Scale Bar

**Ben Adams Architects**

Third Floor  
19 Southpark Street  
London SE1 0UP

T 020 7633 0000  
ben@benadamsarchitects.co.uk  
info@benadamsarchitects.co.uk

**DRAWING NAME:** EXISTING SECOND FLOOR PLAN

**PROJECT NAME:** DRURY LANE - MRP

**DRAWING NO:** P102/-

**JOB NO:** 22-034

**SCALE:** 1:100 @ A3 1:50 @ A1

**STAGE:** PLANNING

PARKER STREET

DRURY LANE

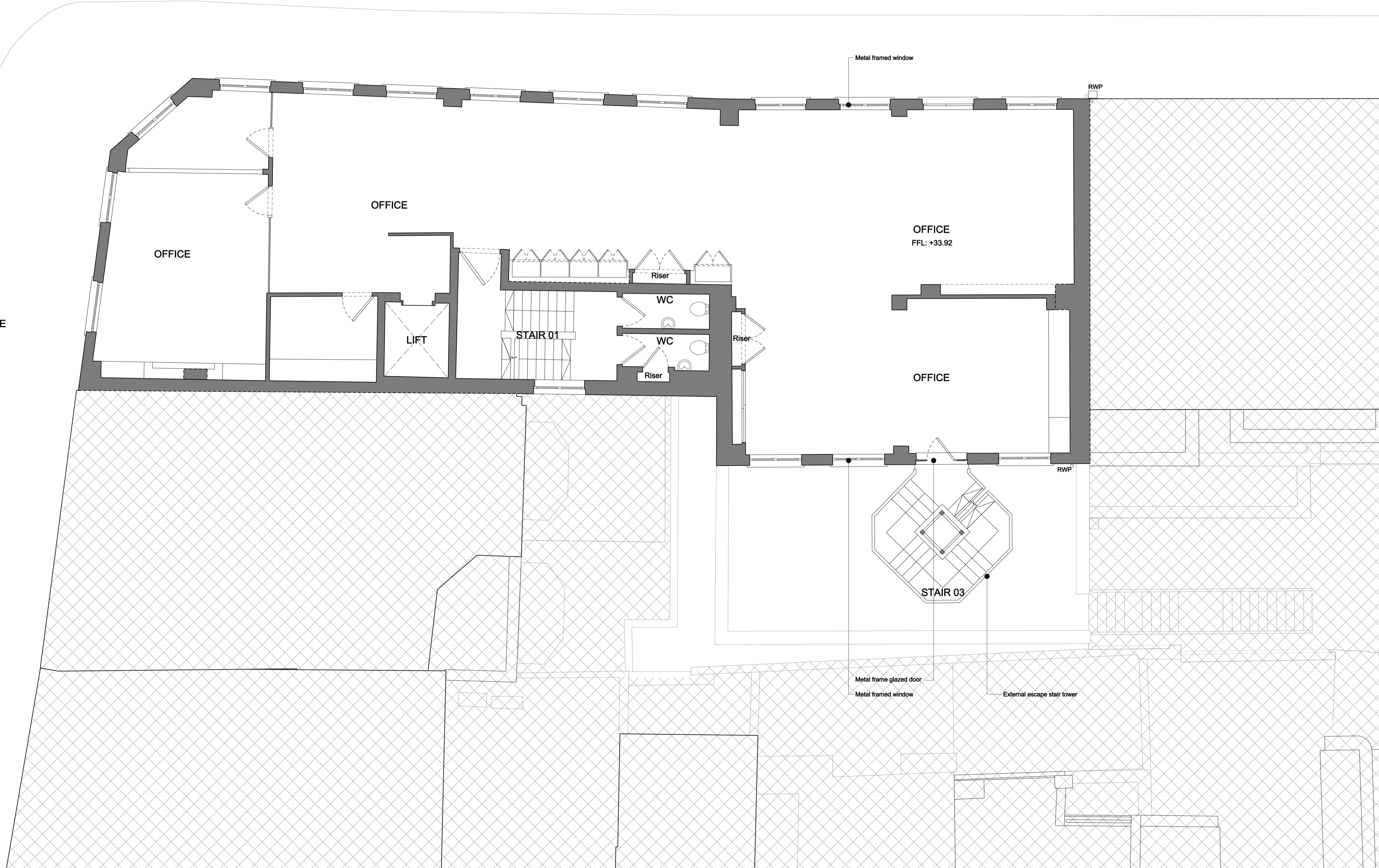

REV.	DATE	DESCRIPTION
-	19.05.2023	PLANNING ISSUE

REV.	DATE	DESCRIPTION

**NOTES:**

1. ALL DIMENSIONS IN MM UNLESS OTHERWISE STATED
2. THIS DRAWING IS TO BE READ IN CONJUNCTION WITH ALL RELEVANT CONTRACT DOCUMENTS
3. THIS DRAWING IS TO BE READ IN CONJUNCTION WITH ALL ENGINEER'S DRAWINGS
4. DO NOT SCALE FROM THIS DRAWING
5. REPORT ANY ERRORS, CONTRADICTIONS, & OMISSIONS TO THE ARCHITECT AS SOON AS POSSIBLE
6. WHEN THIS DRAWING IS ISSUED IN DWG FORMAT IT IS AN UNCONTROLLED VERSION ISSUED TO ENABLE THE RECIPIENT TO PREPARE THEIR OWN DRAWINGS FOR WHICH THEY ARE SOLELY RESPONSIBLE. IT IS BASED ON BACKGROUND INFORMATION CURRENT AT TIME OF ISSUE. BEN ADAMS ARCHITECTS ACCEPTS NO LIABILITY FOR ANY SUCH ALTERATIONS OR ADDITIONS TO OR DISCREPANCIES ARISING OUT OF CHANGES TO SUCH BACKGROUND INFORMATION WHICH OCCUR AFTER IT IS ISSUED BY BEN ADAMS ARCHITECTS.

**KEY:**

0 0.5m 2.5m 5m ■ EXISTING WALLS

Scale Bar

**Ben Adams Architects**

Third Floor  
19 Southpark Street  
London SE1 0UP

T 020 7633 0000  
ben@benadamsarchitects.co.uk  
info@benadamsarchitects.co.uk

**DRAWING NAME:** EXISTING THIRD FLOOR PLAN

**PROJECT NAME:** DRURY LANE - MRP

**DRAWING NO:** P103/-

**JOB NO:** 22-034

**SCALE:** 1:100 @ A3 1:50 @ A1

**STAGE:** PLANNING

PARKER STREET

DRURY LANE

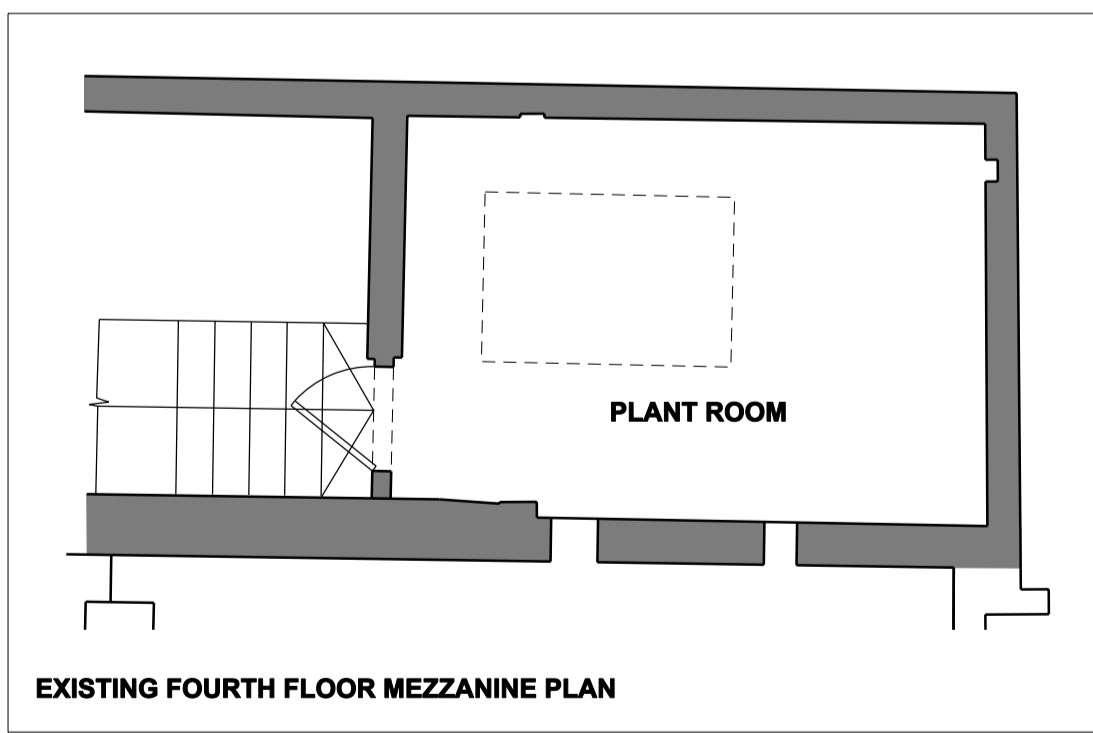
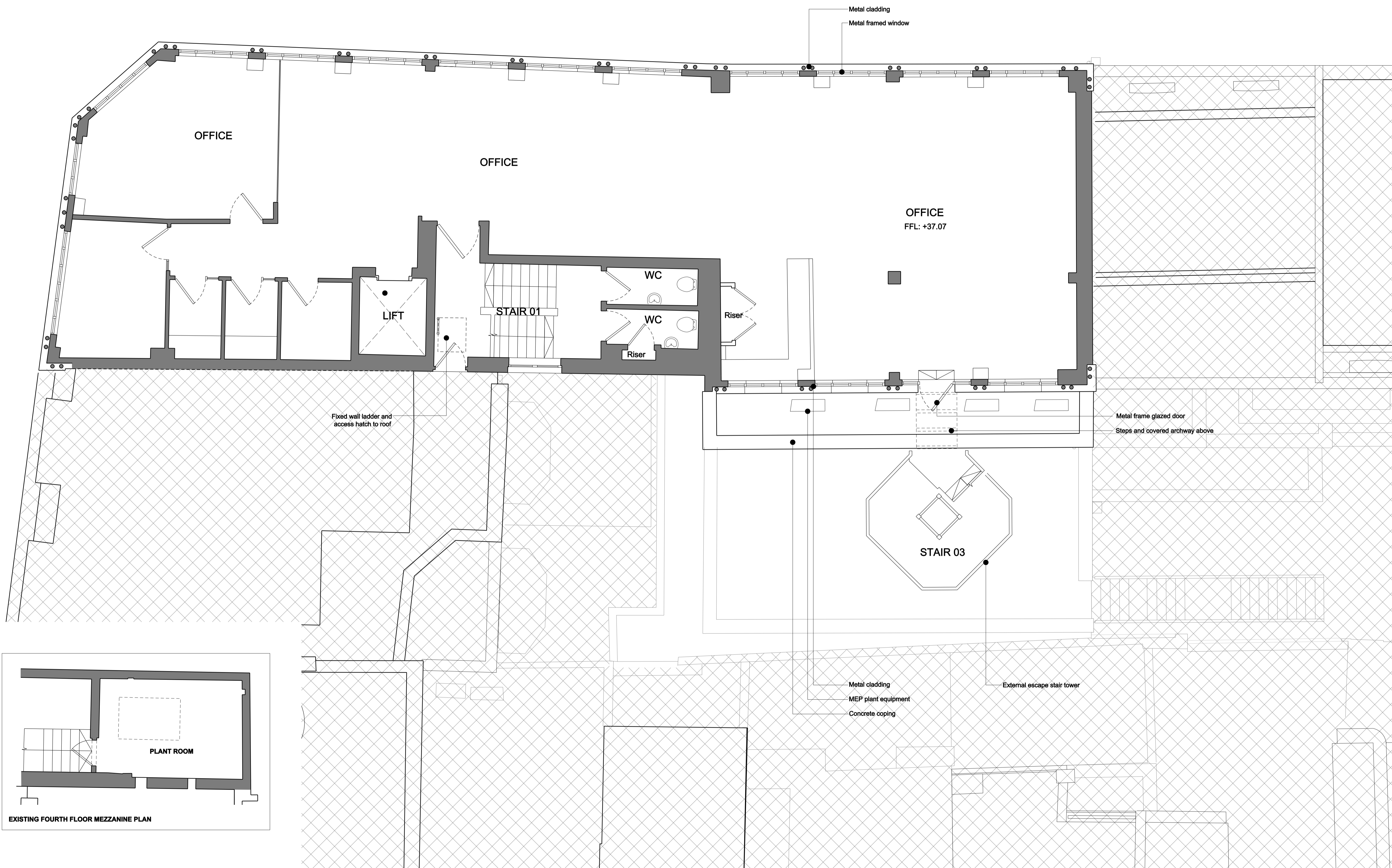

REV.	DATE	DESCRIPTION
-	19.05.2023	PLANNING ISSUE

REV.	DATE	DESCRIPTION

**NOTES:**

1. ALL DIMENSIONS IN MM UNLESS OTHERWISE STATED
2. THIS DRAWING IS TO BE READ IN CONJUNCTION WITH ALL RELEVANT CONTRACT DOCUMENTS
3. THIS DRAWING IS TO BE READ IN CONJUNCTION WITH ALL ENGINEER'S DRAWINGS
4. DO NOT SCALE FROM THIS DRAWING
5. REPORT ANY ERRORS, CONTRADICTIONS, & OMISSIONS TO THE ARCHITECT AS SOON AS POSSIBLE
6. WHEN THIS DRAWING IS ISSUED IN DWG FORMAT IT IS AN UNCONTROLLED VERSION ISSUED TO ENABLE THE RECIPIENT TO PREPARE THEIR OWN DRAWINGS FOR WHICH THEY ARE SOLELY RESPONSIBLE. IT IS BASED ON BACKGROUND INFORMATION CURRENT AT TIME OF ISSUE. BEN ADAMS ARCHITECTS ACCEPTS NO LIABILITY FOR ANY SUCH ALTERATIONS OR ADDITIONS TO OR DISCREPANCIES ARISING OUT OF CHANGES TO SUCH BACKGROUND INFORMATION WHICH OCCUR AFTER IT IS ISSUED BY BEN ADAMS ARCHITECTS.

**KEY:**

0 0.5m 2.5m 5m ■ EXISTING WALLS

Scale Bar

**Ben Adams Architects**

Third Floor  
19 Southbank Street  
London SE1 0UP

T 020 7633 0000  
ben@benadamsarchitects.co.uk  
info@benadamsarchitects.co.uk

**DRAWING NAME:** EXISTING FOURTH FLOOR PLAN

**PROJECT NAME:** DRURY LANE - MRP

**DRAWING NO:** P104/-

**JOB NO:** 22-034

**SCALE:** 1:100 @ A3 1:50 @ A1

**STAGE:** PLANNING

PARKER STREET

DRURY LANE

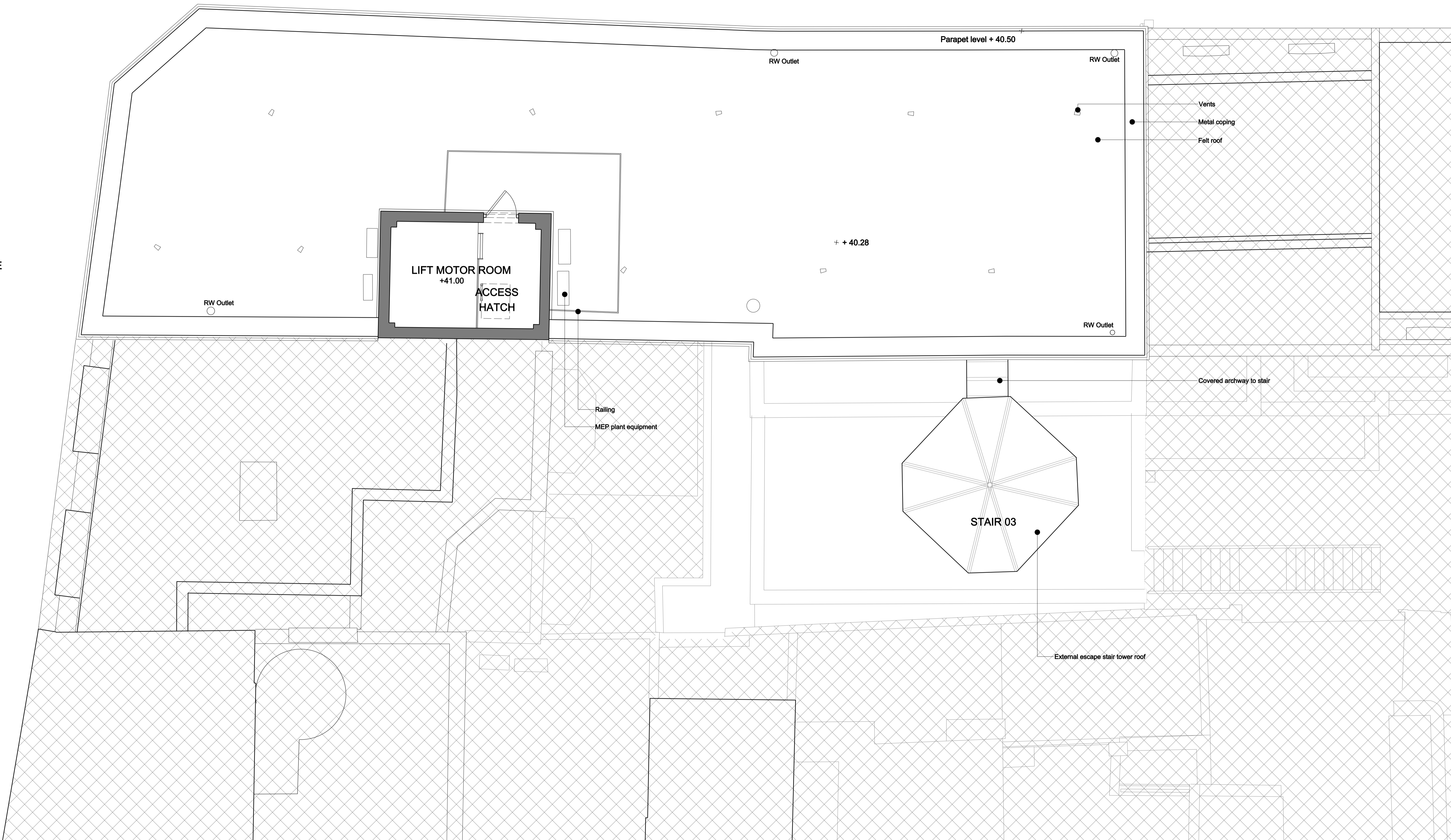

REV.	DATE	DESCRIPTION
-	19.05.2023	PLANNING ISSUE

REV.	DATE	DESCRIPTION

**NOTES:**

1. ALL DIMENSIONS IN MM UNLESS OTHERWISE STATED
2. THIS DRAWING IS TO BE READ IN CONJUNCTION WITH ALL RELEVANT CONTRACT DOCUMENTS
3. THIS DRAWING IS TO BE READ IN CONJUNCTION WITH ALL ENGINEER'S DRAWINGS
4. DO NOT SCALE FROM THIS DRAWING
5. REPORT ANY ERRORS, CONTRADICTIONS, & OMISSIONS TO THE ARCHITECT AS SOON AS POSSIBLE
6. WHEN THIS DRAWING IS ISSUED IN DWG FORMAT IT IS AN UNCONTROLLED VERSION ISSUED TO ENABLE THE RECIPIENT TO PREPARE THEIR OWN DRAWINGS FOR WHICH THEY ARE SOLELY RESPONSIBLE. IT IS BASED ON BACKGROUND INFORMATION CURRENT AT TIME OF ISSUE. BEN ADAMS ARCHITECTS ACCEPTS NO LIABILITY FOR ANY SUCH ALTERATIONS OR ADDITIONS TO OR DISCREPANCIES ARISING OUT OF CHANGES TO SUCH BACKGROUND INFORMATION WHICH OCCUR AFTER IT IS ISSUED BY BEN ADAMS ARCHITECTS.

**KEY:**

0 0.5m 2.5m 5m ■ EXISTING WALLS

Scale Bar

**Ben Adams Architects**

Third Floor  
97 Southpark Street  
London SE1 0UP

T 020 7633 0000  
ben@benadamsarchitects.co.uk  
info@benadamsarchitects.co.uk

**DRAWING NAME:** EXISTING PLANT PLAN

**PROJECT NAME:** DRURY LANE - MRP

**DRAWING NO:** P105/-

**JOB NO:** 22-034

**SCALE:** 1:100 @ A3 1:50 @ A1

**STAGE:** PLANNING



PARKER STREET

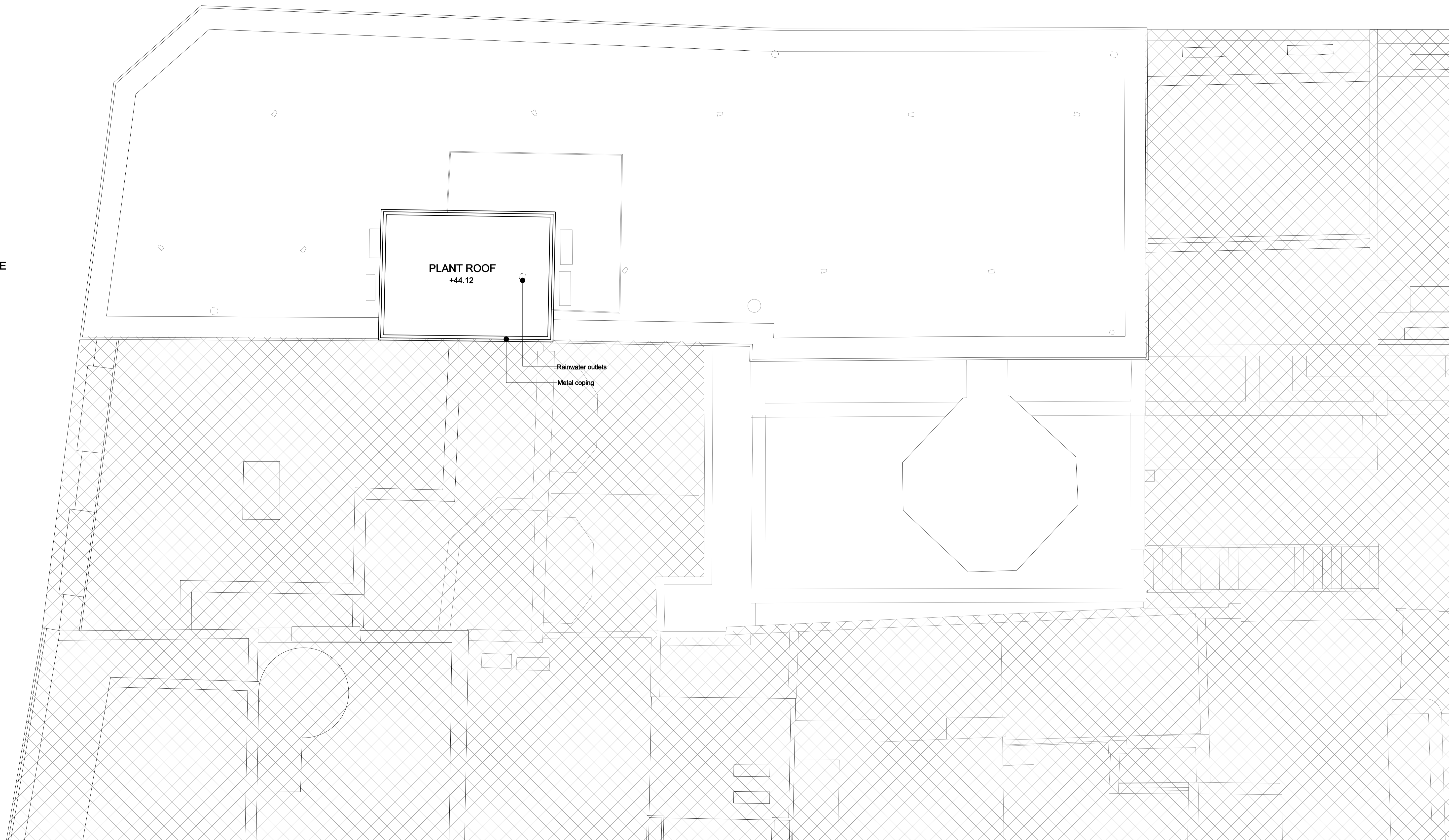

DRURY LANE



REV.	DATE	DESCRIPTION
-	19.05.2023	PLANNING ISSUE

REV.	DATE	DESCRIPTION

**NOTES:**  
 1. ALL DIMENSIONS IN MM UNLESS OTHERWISE STATED  
 2. THIS DRAWING IS TO BE READ IN CONJUNCTION WITH ALL RELEVANT CONTRACT DOCUMENTS  
 3. THIS DRAWING IS TO BE READ IN CONJUNCTION WITH ALL ENGINEER'S DRAWINGS  
 4. DO NOT SCALE FROM THIS DRAWING  
 5. REPORT ANY ERRORS, CONTRADICTIONS, & OMISSIONS TO THE ARCHITECT AS SOON AS POSSIBLE  
 6. WHEN THIS DRAWING IS ISSUED IN DWG FORMAT IT IS AN UNCONTROLLED VERSION ISSUED TO ENABLE THE RECIPIENT TO PREPARE THEIR OWN DRAWINGS FOR WHICH THEY ARE SOLELY RESPONSIBLE. IT IS BASED ON BACKGROUND INFORMATION CURRENT AT TIME OF ISSUE. BEN ADAMS ARCHITECTS ACCEPTS NO LIABILITY FOR ANY SUCH ALTERATIONS OR ADDITIONS TO OR DISCREPANCIES ARISING OUT OF CHANGES TO SUCH BACKGROUND INFORMATION WHICH OCCUR AFTER IT IS ISSUED BY BEN ADAMS ARCHITECTS.

**KEY:**  
 0 0.5m 2.5m 5m  EXISTING WALLS  
 Scale Bar

**Ben Adams Architects** 

Third Floor  
 17 Southbank Street  
 London SE1 0UP

T 020 7633 0000  
 ben@benadamsarchitects.co.uk  
 info@benadamsarchitects.co.uk

**DRAWING NAME:** EXISTING ROOF PLAN

**PROJECT NAME:** DRURY LANE - MRP

**DRAWING NO:** P106/-

**JOB NO:** 22-034

**SCALE:** 1:100 @ A3 1:50 @ A1

**STAGE:** PLANNING

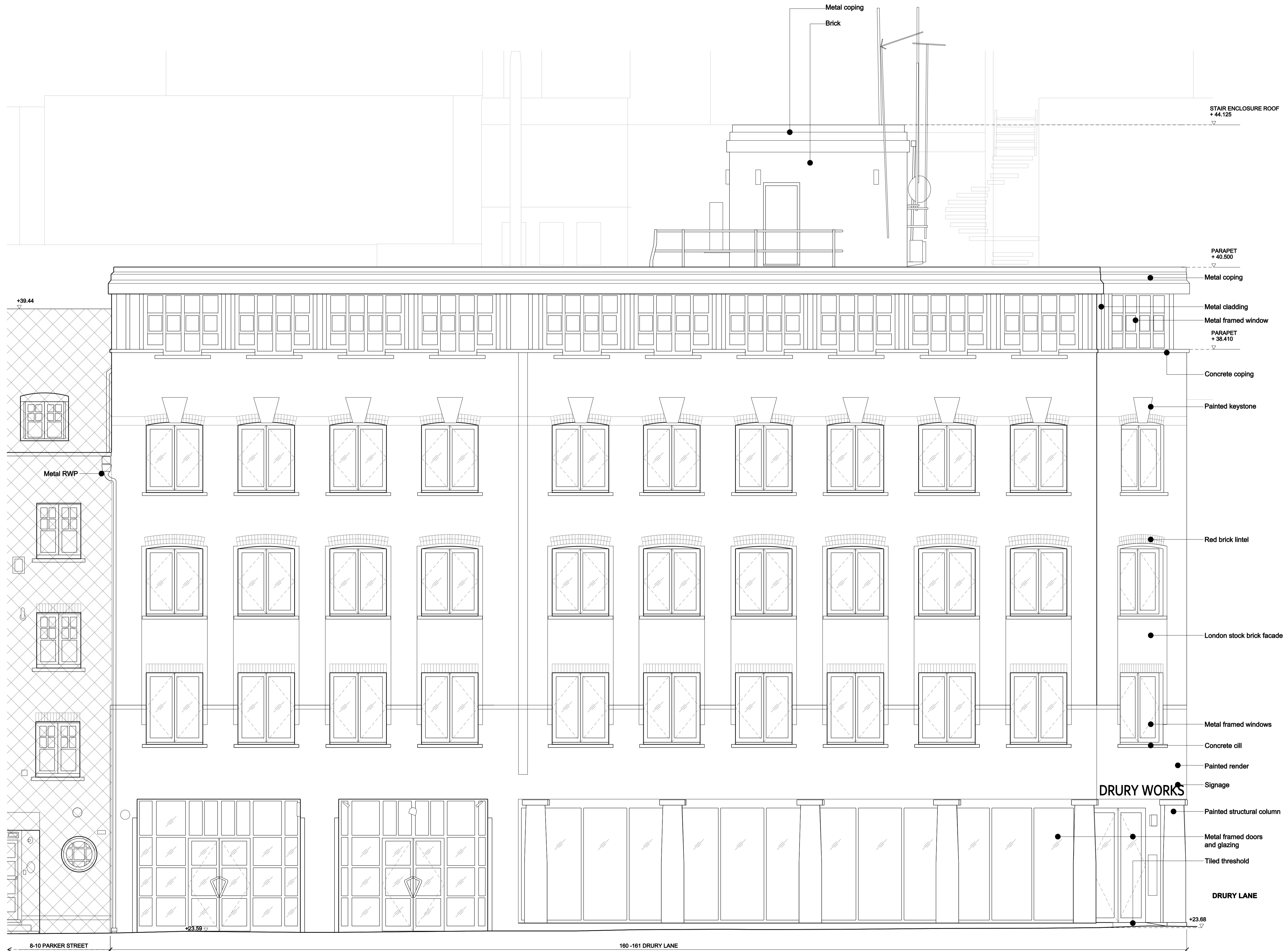

8-10 PARKER STREET

160-161 DRURY LANE

DRURY LANE

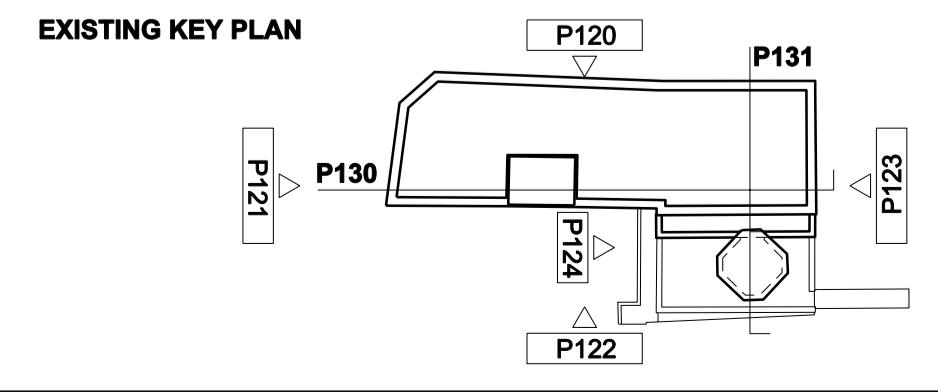

REV.	DATE	DESCRIPTION
-	19.05.2023	PLANNING ISSUE

**NOTES:**

1. ALL DIMENSIONS IN MM UNLESS OTHERWISE STATED
2. THIS DRAWING IS TO BE READ IN CONJUNCTION WITH ALL RELEVANT CONTRACT DOCUMENTS
3. THIS DRAWING IS TO BE READ IN CONJUNCTION WITH ALL ENGINEER'S DRAWINGS
4. DO NOT SCALE FROM THIS DRAWING
5. REPORT ANY ERRORS, CONTRADICTIONS, & OMISSIONS TO THE ARCHITECT AS SOON AS POSSIBLE
6. WHEN THIS DRAWING IS ISSUED IN DWG FORMAT IT IS AN UNCONTROLLED VERSION ISSUED TO ENABLE THE RECIPIENT TO PREPARE THEIR OWN DRAWINGS FOR WHICH THEY ARE SOLELY RESPONSIBLE. IT IS BASED ON BACKGROUND INFORMATION CURRENT AT TIME OF ISSUE. BEN ADAMS ARCHITECTS ACCEPTS NO LIABILITY FOR ANY SUCH ALTERATIONS OR ADDITIONS TO OR DISCREPANCIES ARISING OUT OF CHANGES TO SUCH BACKGROUND INFORMATION WHICH OCCUR AFTER IT IS ISSUED BY BEN ADAMS ARCHITECTS.

**KEY:**

0 0.5m 2.5m 5m

Scale Bar

NOT IN OWNERSHIP BOUNDARY

**Ben Adams Architects**

Third Floor  
97 Southbank Street  
London SE1 0UP

T 020 7633 0000  
ben@benadamsarchitects.co.uk  
info@benadamsarchitects.co.uk

**DRAWING NAME:** EXISTING NORTH WEST ELEVATION - PARKER STREET

**PROJECT NAME:** DRURY LANE - MRP

**DRAWING NO:** P120/-

**JOB NO:** 22-034

**SCALE:** 1:100 @ A3 1:50 @ A1

**STAGE:** PLANNING

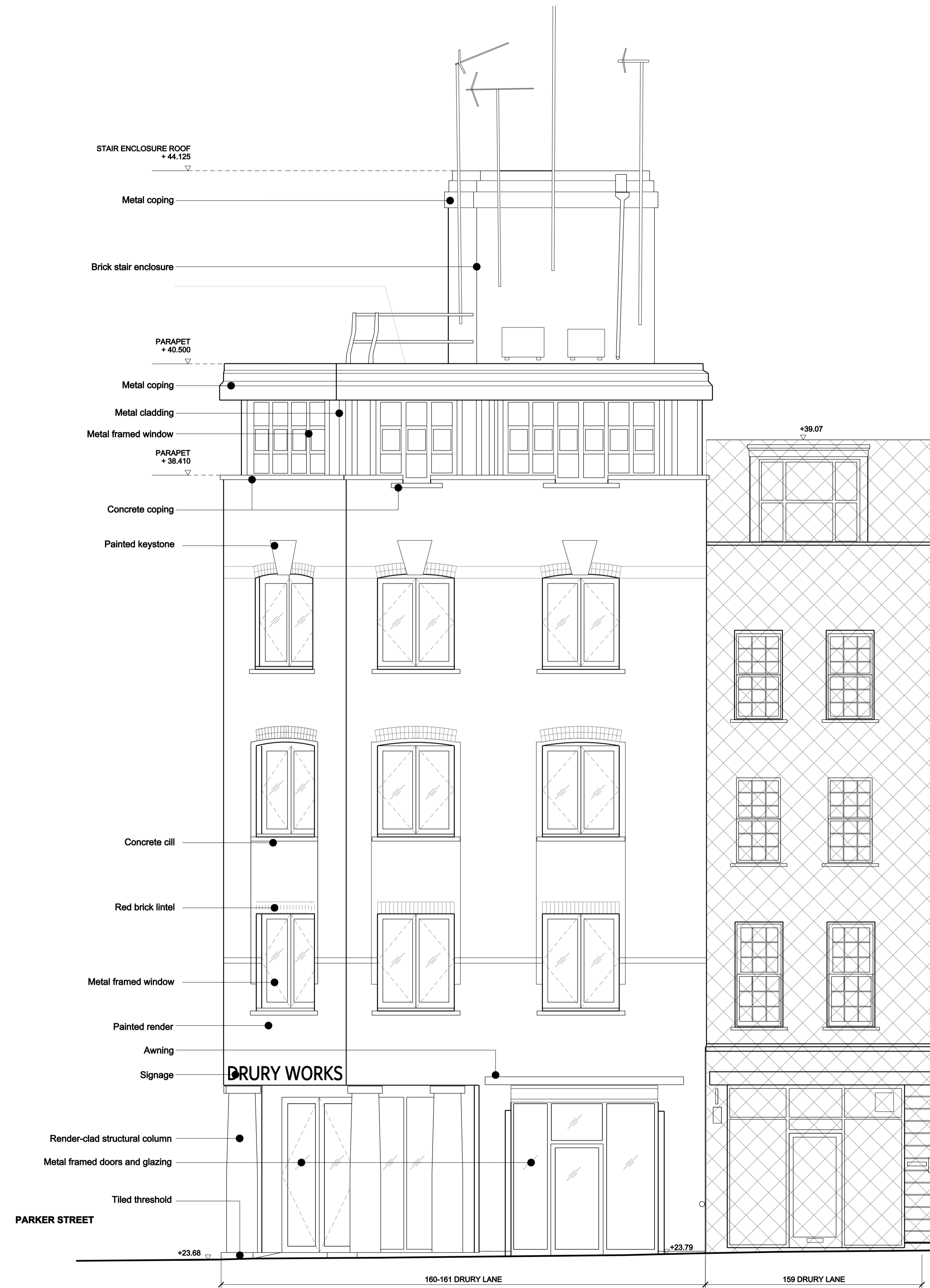

STAIR ENCLOSURE ROOF  
+44.125

Metal coping

Brick stair enclosure

PARAPET  
+40.800

Metal coping

Metal cladding

Metal framed window

PARAPET  
+38.410

Concrete coping

Painted keystone

Concrete cill

Red brick lintel

Metal framed window

Painted render

Awning

Signage

DRURY WORKS

Render-clad structural column

Metal framed doors and glazing

Tiled threshold

PARKER STREET

+23.68

+23.79

160-161 DRURY LANE

159 DRURY LANE

+39.07

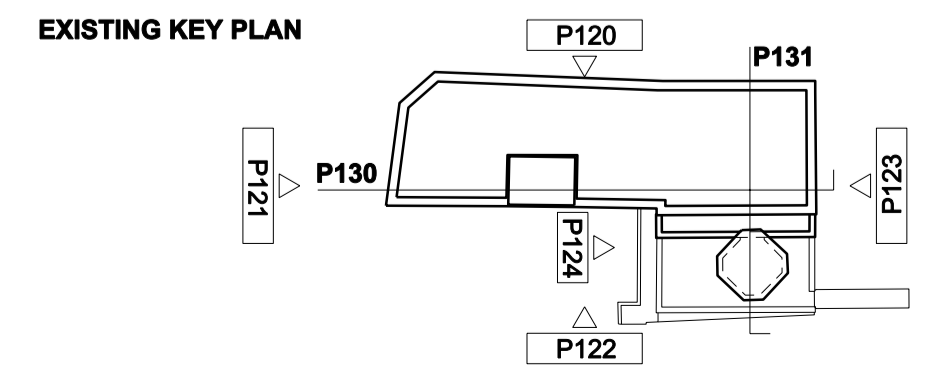

REV.	DATE	DESCRIPTION
-	19.05.2023	PLANNING ISSUE

NOTES:

1. ALL DIMENSIONS IN MM UNLESS OTHERWISE STATED
2. THIS DRAWING IS TO BE READ IN CONJUNCTION WITH ALL RELEVANT CONTRACT DOCUMENTS
3. THIS DRAWING IS TO BE READ IN CONJUNCTION WITH ALL ENGINEER'S DRAWINGS
4. DO NOT SCALE FROM THIS DRAWING
5. REPORT ANY ERRORS, CONTRADICTIONS, & OMISSIONS TO THE ARCHITECT AS SOON AS POSSIBLE
6. WHEN THIS DRAWING IS ISSUED IN DWG FORMAT IT IS AN UNCONTROLLED VERSION ISSUED TO ENABLE THE RECIPIENT TO PREPARE THEIR OWN DRAWINGS FOR WHICH THEY ARE SOLELY RESPONSIBLE. IT IS BASED ON BACKGROUND INFORMATION CURRENT AT TIME OF ISSUE. BEN ADAMS ARCHITECTS ACCEPTS NO LIABILITY FOR ANY SUCH ALTERATIONS OR ADDITIONS TO OR DISCREPANCIES ARISING OUT OF CHANGES TO SUCH BACKGROUND INFORMATION WHICH OCCUR AFTER IT IS ISSUED BY BEN ADAMS ARCHITECTS.

KEY:

0 0.5m 2.5m 5m

Scale Bar

NOT IN OWNERSHIP BOUNDARY

Ben Adams Architects

Third Floor  
79 Southbank Street  
London SE1 0UP

T 020 7633 0000  
ben@benadamsarchitects.co.uk  
info@benadamsarchitects.co.uk

DRAWING NAME: **EXISTING SOUTH WEST ELEVATION - DRURY LANE**

PROJECT NAME: **DRURY LANE - MRP**

JOB NO: **22-034**

SCALE: **1:100 @ A3 1:50 @ A1**

STAGE: **PLANNING**

DRAWING NO: **P121/-**

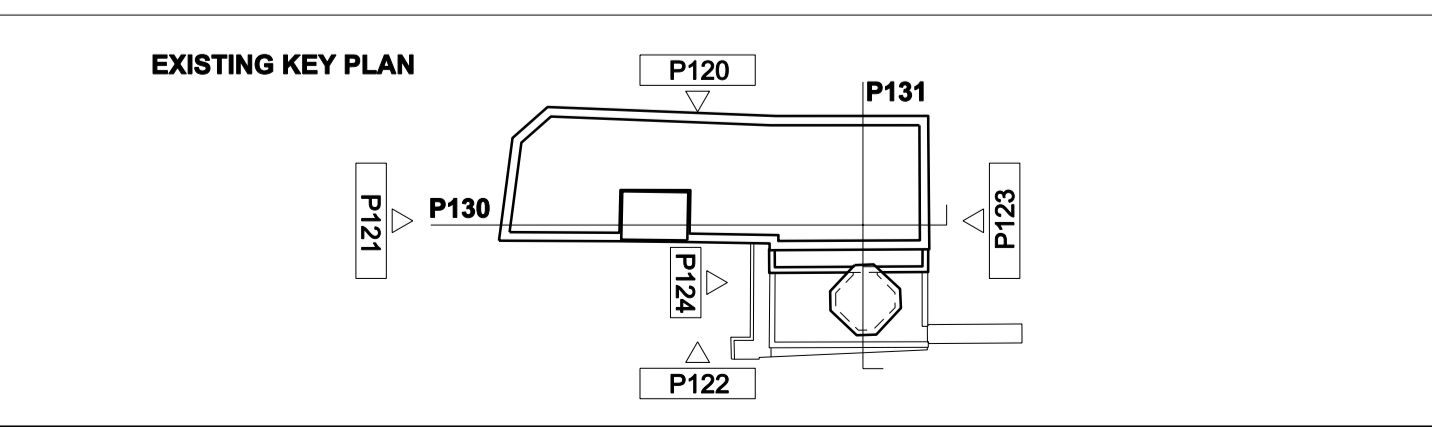
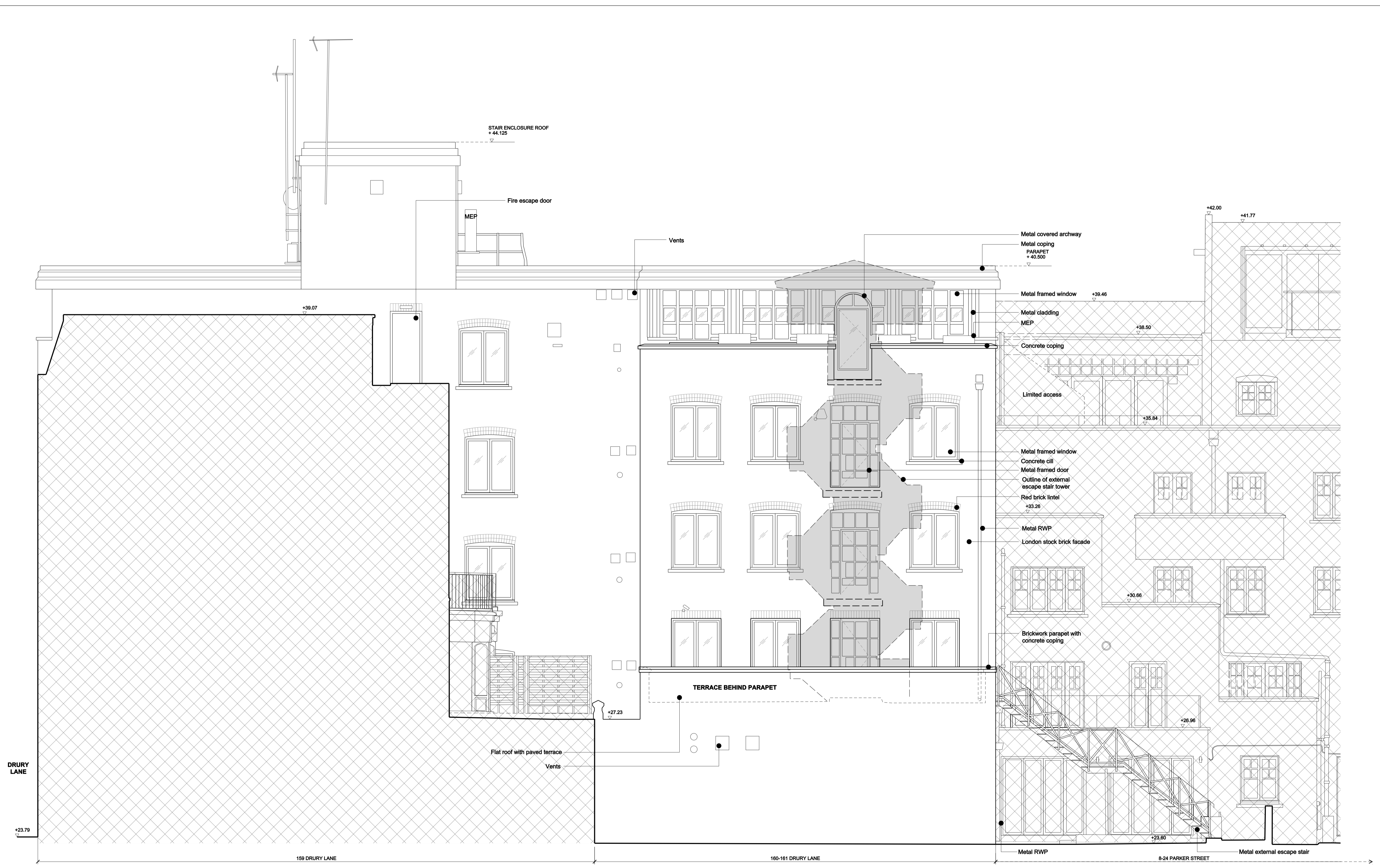

REV.	DATE	DESCRIPTION
-	19.05.2023	PLANNING ISSUE

**NOTES:**

1. ALL DIMENSIONS IN MM UNLESS OTHERWISE STATED
2. THIS DRAWING IS TO BE READ IN CONJUNCTION WITH ALL RELEVANT CONTRACT DOCUMENTS
3. THIS DRAWING IS TO BE READ IN CONJUNCTION WITH ALL ENGINEER'S DRAWINGS
4. DO NOT SCALE FROM THIS DRAWING
5. REPORT ANY ERRORS, CONTRADICTIONS, & OMISSIONS TO THE ARCHITECT AS SOON AS POSSIBLE
6. WHEN THIS DRAWING IS ISSUED IN DWG FORMAT IT IS AN UNCONTROLLED VERSION ISSUED TO ENABLE THE RECIPIENT TO PREPARE THEIR OWN DRAWINGS FOR WHICH THEY ARE SOLELY RESPONSIBLE. IT IS BASED ON BACKGROUND INFORMATION CURRENT AT TIME OF ISSUE. BEN ADAMS ARCHITECTS ACCEPTS NO LIABILITY FOR ANY SUCH ALTERATIONS OR ADDITIONS TO OR DISCREPANCIES ARISING OUT OF CHANGES TO SUCH BACKGROUND INFORMATION WHICH OCCUR AFTER IT IS ISSUED BY BEN ADAMS ARCHITECTS.

**KEY:**

0 0.5m 2.5m 5m  
Scale Bar

NOT IN OWNERSHIP BOUNDARY

**Ben Adams Architects**

Third Floor  
99 Southpark Street  
London SE1 0UP

T 020 7633 0000  
ben@benadamsarchitects.co.uk  
info@benadamsarchitects.co.uk

**DRAWING NAME:** EXISTING SOUTH EAST ELEVATION - REAR FACADE

**PROJECT NAME:** DRURY LANE - MRP

**DRAWING NO:** P122/-

**JOB NO:** 22-034

**SCALE:** 1:100 @ A3 1:50 @ A1

**STAGE:** PLANNING

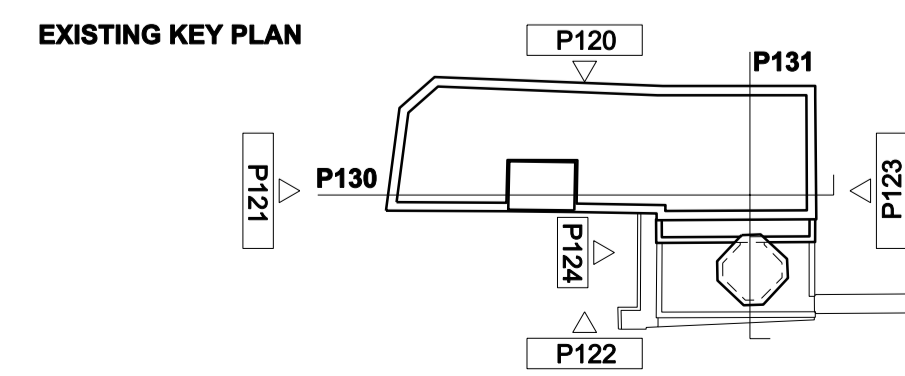
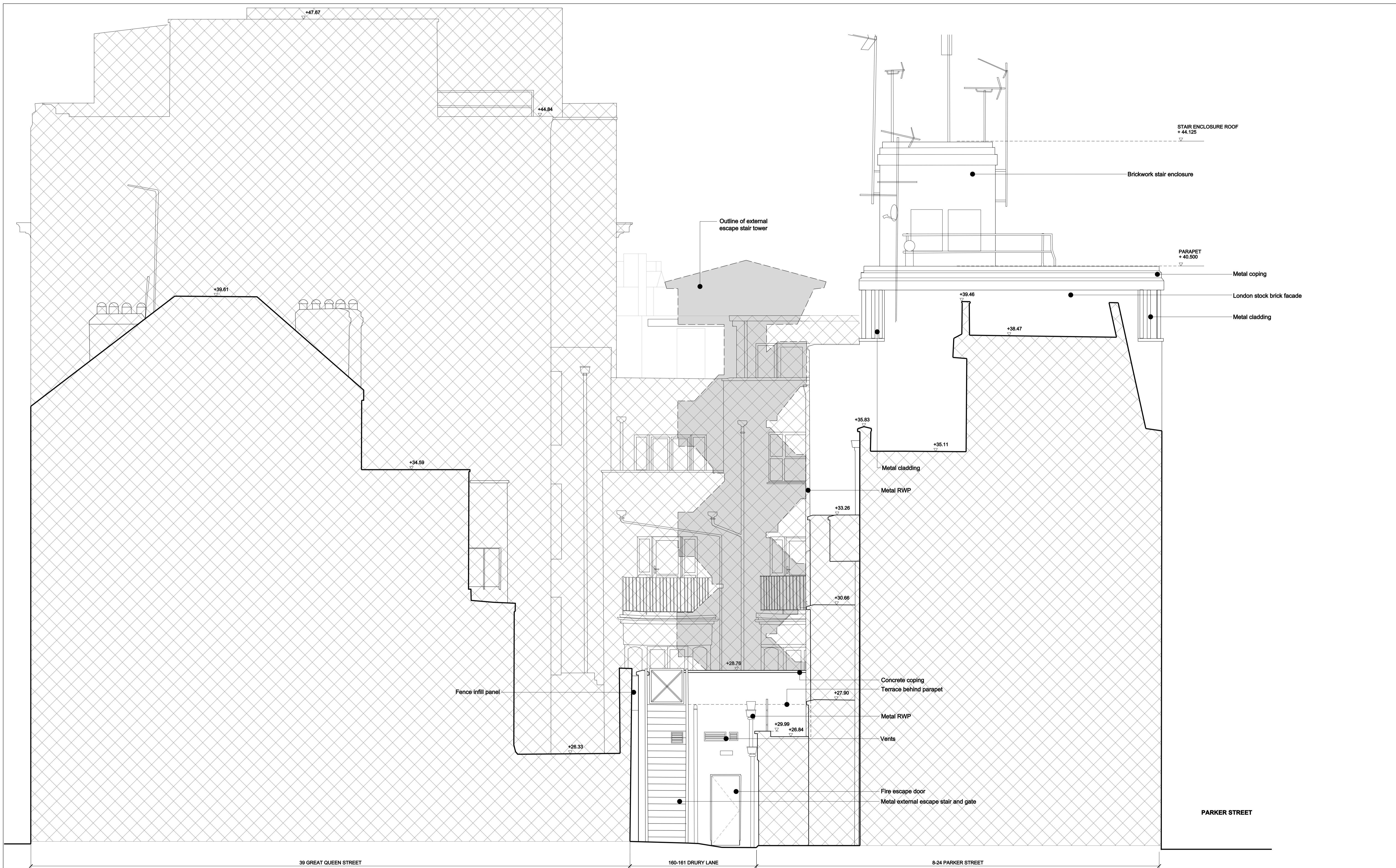

REV.	DATE	DESCRIPTION
-	19.05.2023	PLANNING ISSUE

**NOTES:**

- ALL DIMENSIONS IN MM UNLESS OTHERWISE STATED
- THIS DRAWING IS TO BE READ IN CONJUNCTION WITH ALL RELEVANT CONTRACT DOCUMENTS
- THIS DRAWING IS TO BE READ IN CONJUNCTION WITH ALL ENGINEER'S DRAWINGS
- DO NOT SCALE FROM THIS DRAWING
- REPORT ANY ERRORS, CONTRADICTIONS, & OMISSIONS TO THE ARCHITECT AS SOON AS POSSIBLE
- WHEN THIS DRAWING IS ISSUED IN DWG FORMAT IT IS AN UNCONTROLLED VERSION ISSUED TO ENABLE THE RECIPIENT TO PREPARE THEIR OWN DRAWINGS FOR WHICH THEY ARE SOLELY RESPONSIBLE. IT IS BASED ON BACKGROUND INFORMATION CURRENT AT TIME OF ISSUE.
- BEN ADAMS ARCHITECTS ACCEPTS NO LIABILITY FOR ANY SUCH ALTERATIONS OR ADDITIONS TO OR DISCREPANCIES ARISING OUT OF CHANGES TO SUCH BACKGROUND INFORMATION WHICH OCCUR AFTER IT IS ISSUED BY BEN ADAMS ARCHITECTS.

**KEY:**

0 0.5m 2.5m 5m  
Scale Bar

NOT IN OWNERSHIP BOUNDARY

**Ben Adams Architects**

Third Floor  
97 Southbank Street  
London SE1 0UP

T 020 7633 0000  
ben@benadamsarchitects.co.uk  
info@benadamsarchitects.co.uk

**JOB NO:** 22-034  
**SCALE:** 1:100 @ A3 1:50 @ A1  
**STAGE:** PLANNING

**DRAWING NAME:** EXISTING NORTH EAST ELEVATION - REAR FACADE

**PROJECT NAME:** DRURY LANE - MRP

**DRAWING NO:** P123/-

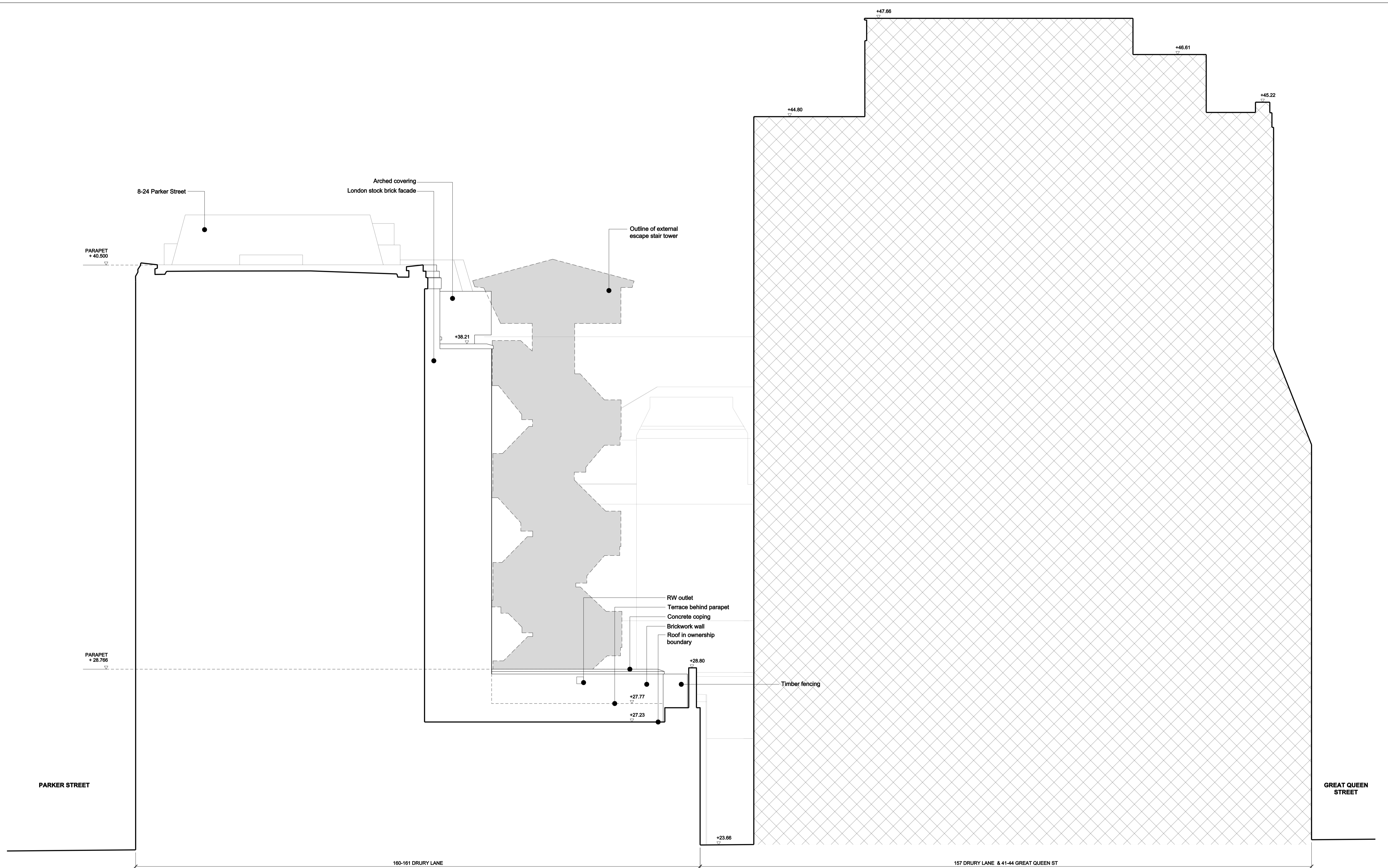

EXISTING KEY PLAN

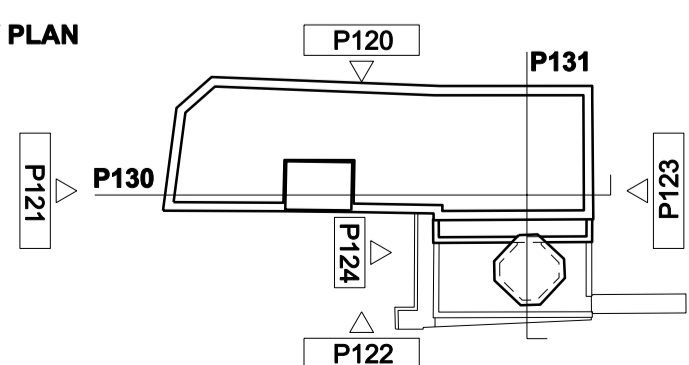

REV.	DATE	DESCRIPTION
-	19.05.2023	PLANNING ISSUE

**NOTES:**

1. ALL DIMENSIONS IN MM UNLESS OTHERWISE STATED
2. THIS DRAWING IS TO BE READ IN CONJUNCTION WITH ALL RELEVANT CONTRACT DOCUMENTS
3. THIS DRAWING IS TO BE READ IN CONJUNCTION WITH ALL ENGINEER'S DRAWINGS
4. DO NOT SCALE FROM THIS DRAWING
5. REPORT ANY ERRORS, CONTRADICTIONS, & OMISSIONS TO THE ARCHITECT AS SOON AS POSSIBLE
6. WHEN THIS DRAWING IS ISSUED IN DWG FORMAT IT IS AN UNCONTROLLED VERSION ISSUED TO ENABLE THE RECIPIENT TO PREPARE THEIR OWN DRAWINGS FOR WHICH THEY ARE SOLELY RESPONSIBLE. IT IS BASED ON BACKGROUND INFORMATION CURRENT AT TIME OF ISSUE. BEN ADAMS ARCHITECTS ACCEPTS NO LIABILITY FOR ANY SUCH ALTERATIONS OR ADDITIONS TO OR DISCREPANCIES ARISING OUT OF CHANGES TO SUCH BACKGROUND INFORMATION WHICH OCCUR AFTER IT IS ISSUED BY BEN ADAMS ARCHITECTS.

**KEY:**

Scale Bar

NOT IN OWNERSHIP BOUNDARY

**Ben Adams Architects**

Third Floor  
37 Southbank Street  
London SE1 0UP

T 020 7633 0000  
ben@benadamsarchitects.co.uk  
info@benadamsarchitects.co.uk

**JOB NO:** 22-034  
**SCALE:** 1:100 @ A3 1:50 @ A1  
**STAGE:** PLANNING

**DRAWING NAME:** PROPOSED SOUTHWEST 'COURTYARD' ELEVATION

**PROJECT NAME:** DRURY LANE - MRP

**DRAWING NO:** P124/-

STAIR ENCLOSURE ROOF  
+44.125

PARAPET  
+40.500

FOURTH FLOOR FFL  
+37.070

THIRD FLOOR FFL  
+33.920

SECOND FLOOR FFL  
+30.790

FIRST FLOOR FFL  
+27.640

GROUND FLOOR FFL  
+23.810

LIFT MOTOR ROOM

Fixed wall ladder to roof

PLANT

OFFICE

OFFICE

OFFICE

OFFICE

OFFICE

OFFICE

OFFICE

LIFT SHAFT

WC

OFFICE

WC

OFFICE

WC

OFFICE

WC

OFFICE

OFFICE

Metal framed glazed door

RETAIL

DRURY LANE

WC

OFFICE

OFFICE

OFFICE

PLANT

WC

CORRIDOR

RETAIL

RETAIL

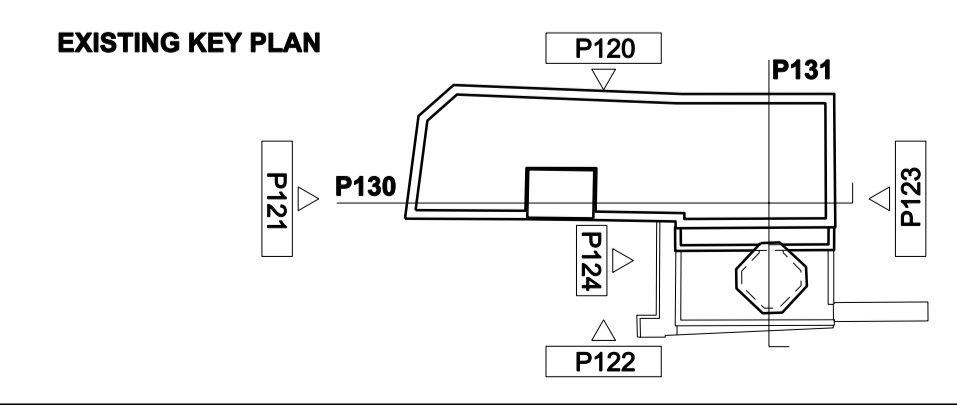

REV.	DATE	DESCRIPTION
-	19.05.2023	PLANNING ISSUE

NOTES:

- ALL DIMENSIONS IN MM UNLESS OTHERWISE STATED
- THIS DRAWING IS TO BE READ IN CONJUNCTION WITH ALL RELEVANT CONTRACT DOCUMENTS
- THIS DRAWING IS TO BE READ IN CONJUNCTION WITH ALL ENGINEER'S DRAWINGS
- DO NOT SCALE FROM THIS DRAWING
- REPORT ANY ERRORS, CONTRADICTIONS, & OMISSIONS TO THE ARCHITECT AS SOON AS POSSIBLE
- WHEN THIS DRAWING IS ISSUED IN DWG FORMAT IT IS AN UNCONTROLLED VERSION ISSUED TO ENABLE THE RECIPIENT TO PREPARE THEIR OWN DRAWINGS FOR WHICH THEY ARE SOLELY RESPONSIBLE. IT IS BASED ON BACKGROUND INFORMATION CURRENT AT TIME OF ISSUE.
- BEN ADAMS ARCHITECTS ACCEPTS NO LIABILITY FOR ANY SUCH ALTERATIONS OR ADDITIONS TO OR DISCREPANCIES ARISING OUT OF CHANGES TO SUCH BACKGROUND INFORMATION WHICH OCCUR AFTER IT IS ISSUED BY BEN ADAMS ARCHITECTS.

KEY:

0 0.5m 2.5m 5m

Scale Bar

EXISTING WALLS

Ben Adams Architects

Third Floor  
99 Southbank Street  
London SE1 0UP

T 020 7633 0000  
ben@benadamsarchitects.co.uk  
info@benadamsarchitects.co.uk

JOB NO: 22-034  
SCALE: 1:100 @ A3 1:50 @ A1  
STAGE: PLANNING

DRAWING NAME: EXISTING SECTION AA

PROJECT NAME: DRURY LANE - MRP

DRAWING NO: P130/-

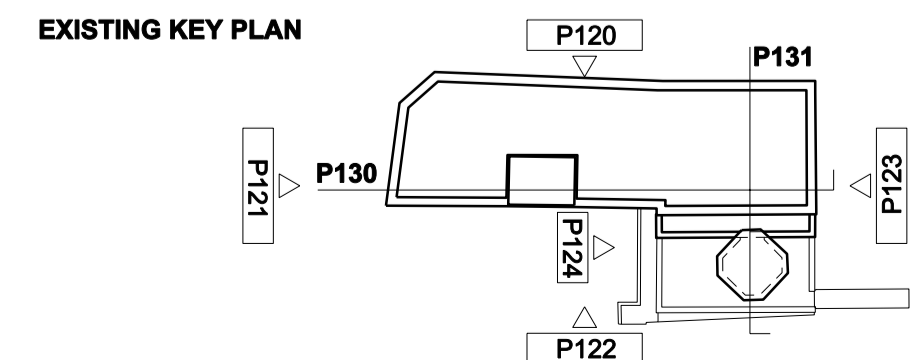
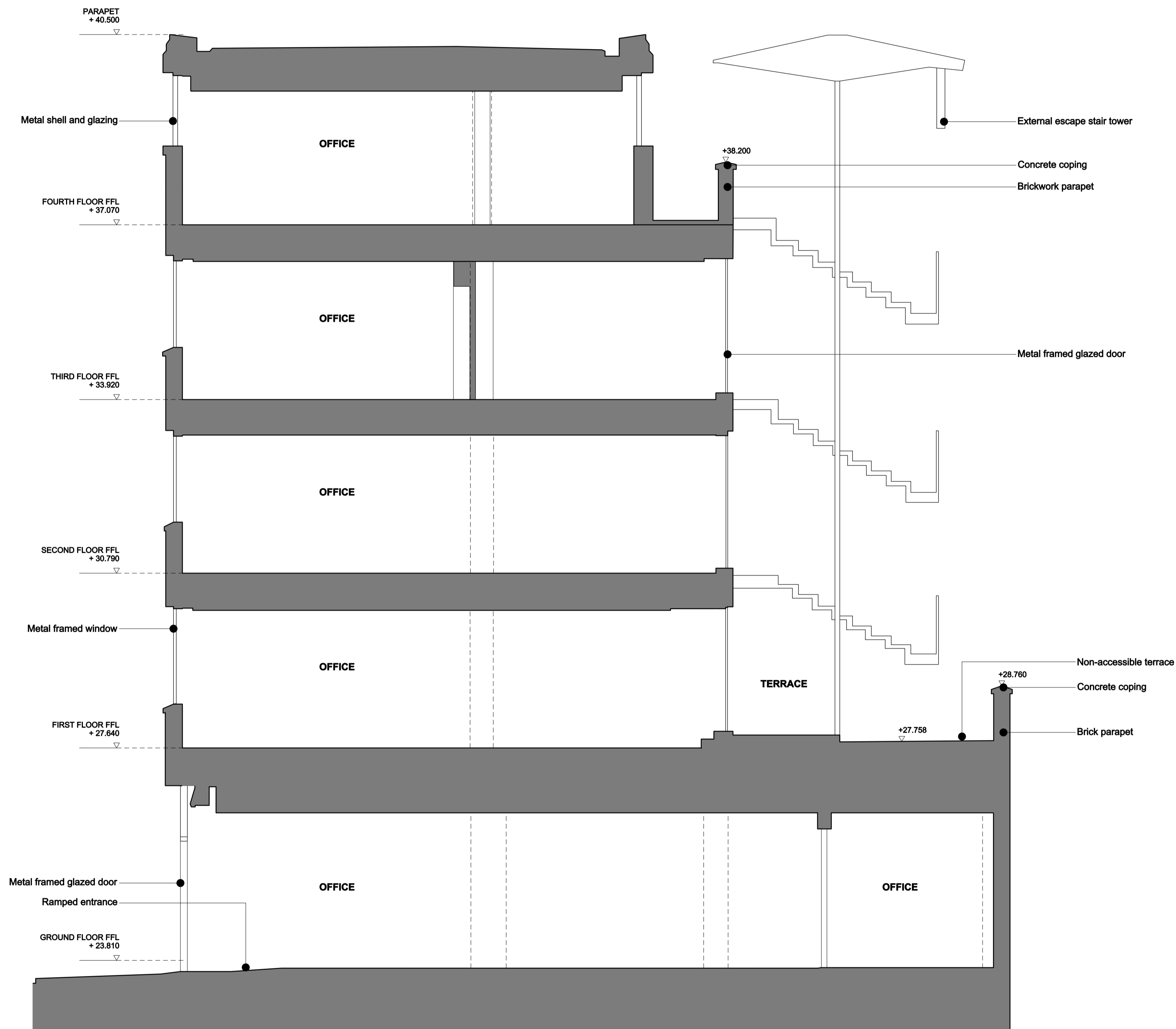

REV.	DATE	DESCRIPTION
-	19.05.2023	PLANNING ISSUE

**NOTES:**

- ALL DIMENSIONS IN MM UNLESS OTHERWISE STATED
- THIS DRAWING IS TO BE READ IN CONJUNCTION WITH ALL RELEVANT CONTRACT DOCUMENTS
- THIS DRAWING IS TO BE READ IN CONJUNCTION WITH ALL ENGINEER'S DRAWINGS
- DO NOT SCALE FROM THIS DRAWING
- REPORT ANY ERRORS, CONTRADICTIONS, & OMISSIONS TO THE ARCHITECT AS SOON AS POSSIBLE
- WHEN THIS DRAWING IS ISSUED IN DWG FORMAT IT IS AN UNCONTROLLED VERSION ISSUED TO ENABLE THE RECIPIENT TO PREPARE THEIR OWN DRAWINGS FOR WHICH THEY ARE SOLELY RESPONSIBLE. IT IS BASED ON BACKGROUND INFORMATION CURRENT AT TIME OF ISSUE. BEN ADAMS ARCHITECTS ACCEPTS NO LIABILITY FOR ANY SUCH ALTERATIONS OR ADDITIONS TO OR DISCREPANCIES ARISING OUT OF CHANGES TO SUCH BACKGROUND INFORMATION WHICH OCCUR AFTER IT IS ISSUED BY BEN ADAMS ARCHITECTS.

**KEY:**

0 0.5m 2.5m 5m

Scale Bar

■ EXISTING WALLS

**Ben Adams Architects**

Third Floor  
17 Southpark Street  
London SE1 0UP

T 020 7633 0000  
ben@benadamsarchitects.co.uk  
info@benadamsarchitects.co.uk

**JOB NO:** 22-034  
**SCALE:** 1:100 @ A3 1:50 @ A1  
**STAGE:** PLANNING

<b>DRAWING NAME:</b>	EXISTING SECTION BB
<b>PROJECT NAME:</b>	DRURY LANE - MRP
<b>DRAWING NO:</b>	<b>P131/-</b>