

1 PROPOSED - LEFT SIDE ELEVATION PART  
SCALE: 1:25

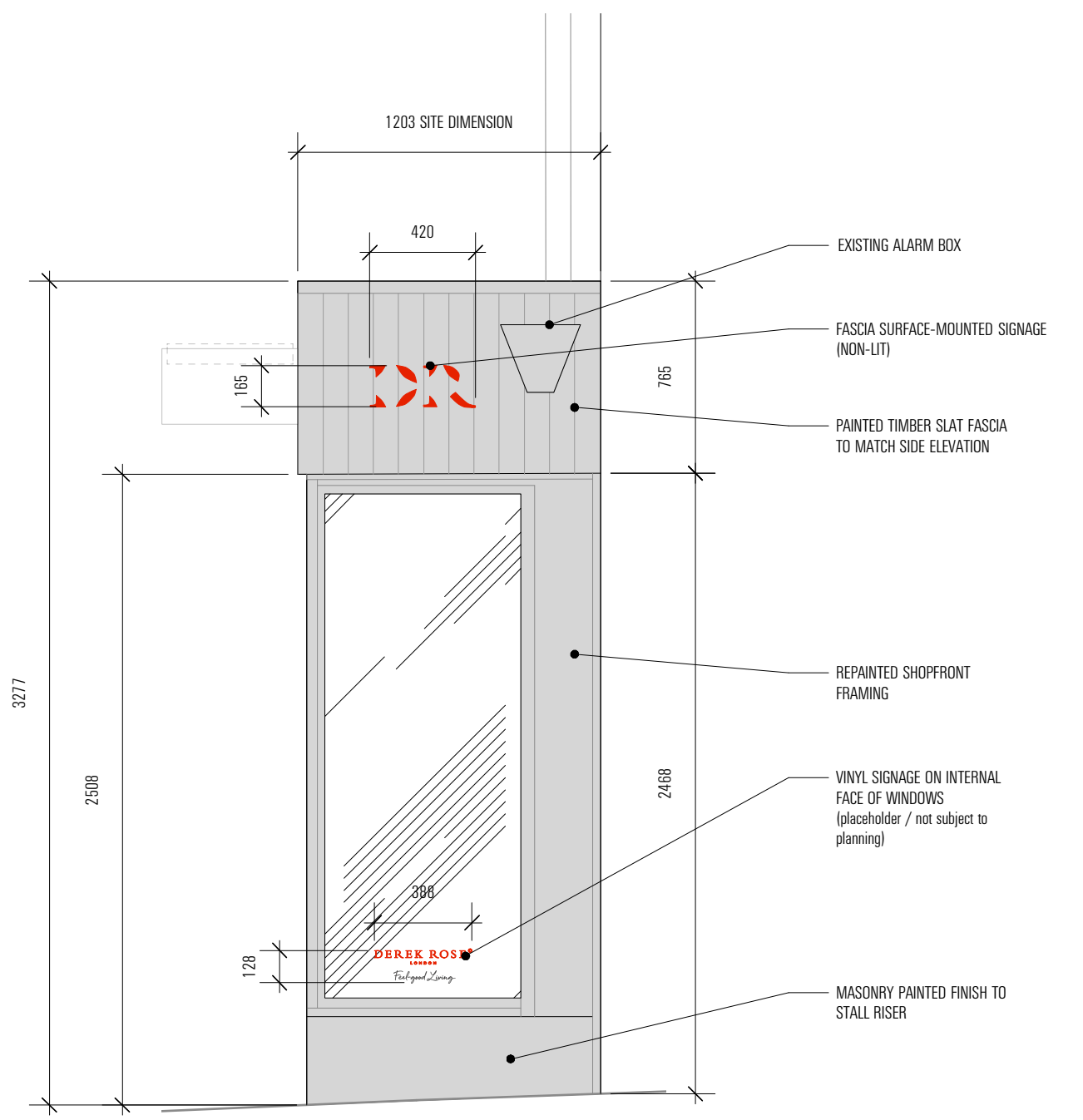

2 PROPOSED - RIGHT SIDE ELEVATION  
SCALE: 1:25