

Made-to-order, double glazed, high performance, traditionally operated timber sash window for conservation areas.
Lomax + Wood or equally approved.

All lower ground and ground floor glazing to be toughened safety glass for security. Refer to details for dimensions of all timber members.

Horns to match original profile

Dims Vary

Fully weather-stripped for thermal and acoustic performance.

Three coat white factory finished spray applied micro-porous paint RAL 9010 as standard.

Hardwood sill

Sizes vary - refer to schedule
Ironmongery - refer to Interior Designer Ironmongery Schedule

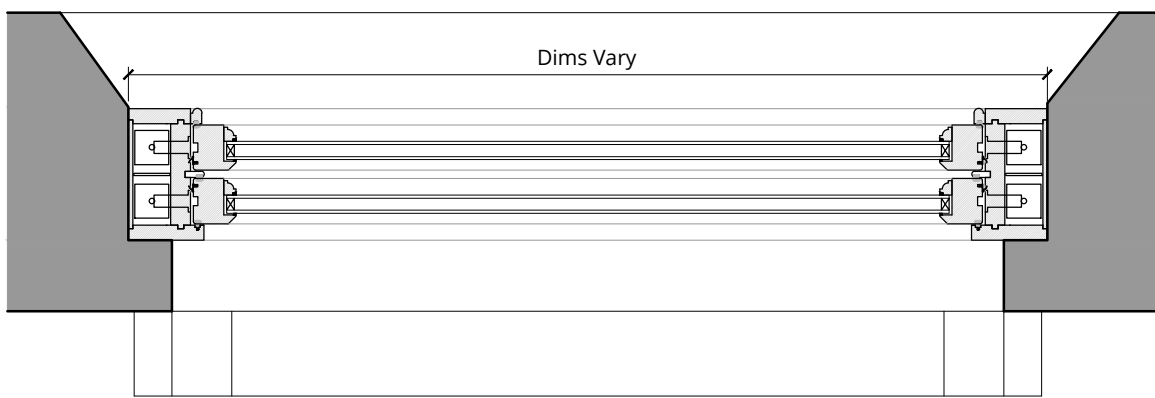

Dims Vary

- WL-01 WL-02 WL-03 WL-04 WL-05 WL-08
- WG-01 WG-02 WG-03 WG-13 WG-14 WG-15 WG-16 WG-17 WG-18 WG-20
- W1-01 W1-02 W1-03 W1-04 W1-05 W1-06 W1-07 W1-08 W1-12 W1-13
- W2-01 W2-02 W2-03 W2-04 W2-05 W2-06 W2-07 W2-08 W2-10

W I N D O W D E T A I L - T Y P E A

T I M B E R F R A M E D S A S H W I N D O W S T O R E P L A C E E X I S T I N G

GENERAL NOTES:

- Do not scale from drawings.
- All works to be in accordance with Local Authority's Bylaws.
- The Contractor shall inform the Building Control Inspector of any work that affects the structure of the building, and any other works which require notification, before the work commences.
- Materials and workmanship are to be to the latest British Standards and European Standards where applicable.
- Where this specification refers to a Standard which has been updated the most recent Standard is to be used.
- All mechanical systems are to be designed and installed in accordance with Building Regulations, the latest relevant British or European Standards, and the manufacturer's instructions.
- The contractor shall check all dimensions on site and report any errors. He is to check any discrepancies and report back to the Architect.

NOT FOR CONSTRUCTION:

**ALL DIMENSIONS TO BE CHECKED ON SITE PRIOR TO MANUFACTURE
SHOP DRAWINGS TO BE APPROVED BY ARCHITECT PRIOR TO MANUFACTURE
WINDOW DETAILS SUBJECT TO APPROVAL BY LPA**



London 16 Lambton Place Notting Hill
London W11 2SH T +44 (0)20 7229 3125
Oxford Chandos Yard 83 Bicester Road
Long Crendon HP18 9EE T +44 (0)1844 203310
W www.wolffarchitects.co.uk E info@wolffarchitects.co.uk
This drawing is protected under Copyright and at no time should any portion be reproduced or copied without the permission of the Architect (Design Copyright Act 1968).
It must not be used for purposes other than that for which it is provided. It is supplied without liability for any errors or omissions. All dimensions to be checked on site.

Rev.	Description	Date	Rev.	Description	Date
0	First issue.	21.02.23			

Project Title				
42 Elsworthy Road London NW3 3DL				
Drawing Title				
Proposed Windows - TYPE A				
Status	Drawn by	Checked by		
CONSTRUCTION				
Scale	Project No.	Work Stage	Dwg. No.	Rev.
1:10 @ A3	2164	CN	750	0



Made-to-order, double glazed, high performance, traditionally operated timber casement window for conservation areas.
Lomax + Wood or equally approved.

All lower ground and ground floor glazing to be toughened safety glass for security. Refer to details for dimensions of all timber members.

Sizes vary - refer to schedule

Fully weather-stripped for thermal and acoustic performance.

Three coat white factory finished spray applied micro-porous paint RAL 9010 as standard.

Ironmongery - refer to Interior Designer Ironmongery Schedule

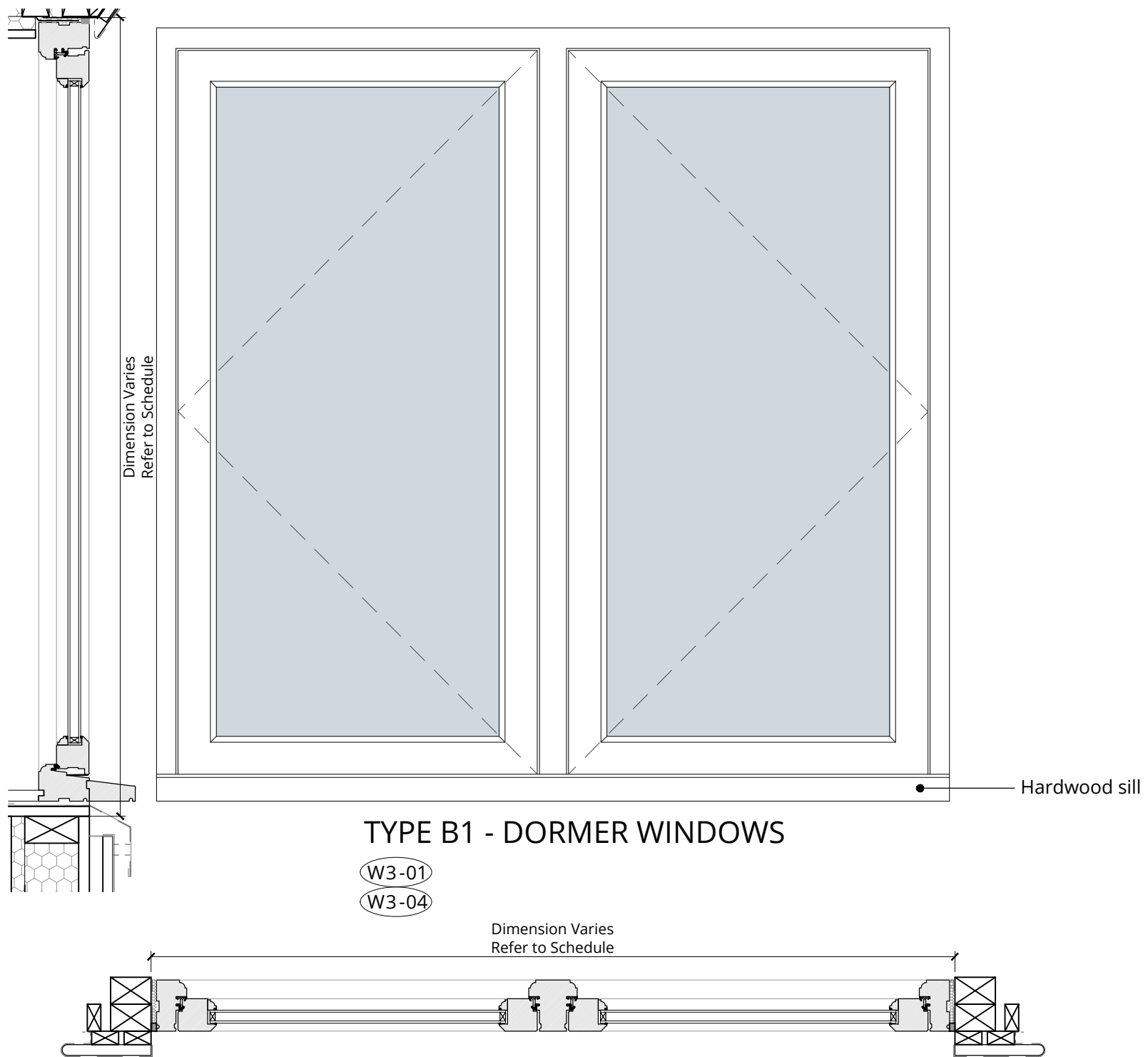

TYPE B1 - DORMER WINDOWS

W3-01
W3-04

W I N D O W D E T A I L - T Y P E B
T I M B E R F R A M E D C A S E M E N T W I N D O W S

GENERAL NOTES:

- Do not scale from drawings.
- All works to be in accordance with Local Authority's Bylaws.
- The Contractor shall inform the Building Control Inspector of any work that affects the structure of the building, and any other works which require notification, before the work commences.
- Materials and workmanship are to be to the latest British Standards and European Standards where applicable.
- Where this specification refers to a Standard which has been updated the most recent Standard is to be used.
- All mechanical systems are to be designed and installed in accordance with Building Regulations, the latest relevant British or European Standards, and the manufacturer's instructions.
- The contractor shall check all dimensions on site and report any errors. He is to check any discrepancies and report back to the Architect.

NOT FOR CONSTRUCTION:

**ALL DIMENSIONS TO BE CHECKED ON SITE PRIOR TO MANUFACTURE
SHOP DRAWINGS TO BE APPROVED BY ARCHITECT PRIOR TO MANUFACTURE
WINDOW DETAILS SUBJECT TO APPROVAL BY LPA**



London 16 Lambton Place Notting Hill
London W11 2SH T +44 (0)20 7229 3125
Oxford Chandos Yard 83 Bicester Road
Long Crendon HP18 9EE T +44 (0)1844 203310
W www.wolffarchitects.co.uk E info@wolffarchitects.co.uk
This drawing is protected under Copyright and at no time should any portion be reproduced or copied without the permission of the Architect (Design Copyright Act 1968).
It must not be used for purposes other than that for which it is provided. It is supplied without liability for any errors or omissions. All dimensions to be checked on site.

Rev.	Description	Date	Rev.	Description	Date
0	First issue.	21.02.23			

Project Title					
42 Elsworthy Road London NW3 3DL					
Drawing Title					
Proposed Windows - TYPE B1 & B2					
Status		Drawn by		Checked by	
CONSTRUCTION					
Scale	Project No.	Work Stage	Dwg. No.	Rev.	
1:10 @ A3	2164	CN	751	0	



Made-to-order, double glazed, high performance, traditionally operated timber casement window for conservation areas.
 All lower ground and ground floor glazing to be toughened safety glass for security. Refer to details for dimensions of all timber members.
 Lomax + Wood or equally approved.
 Sizes vary - refer to schedule. Fully weather-stripped for thermal and acoustic performance.
 Three coat white factory finished spray applied micro-porous paint RAL 9010 as standard.
 Ironmongery - refer to Interior Designer Ironmongery Schedule. Do not scale from drawings

NOT FOR CONSTRUCTION:
 ALL DIMENSIONS TO BE CHECKED ON SITE PRIOR TO MANUFACTURE
 SHOP DRAWINGS TO BE APPROVED BY ARCHITECT PRIOR TO MANUFACTURE
 WINDOW DETAILS SUBJECT TO APPROVAL BY LPA

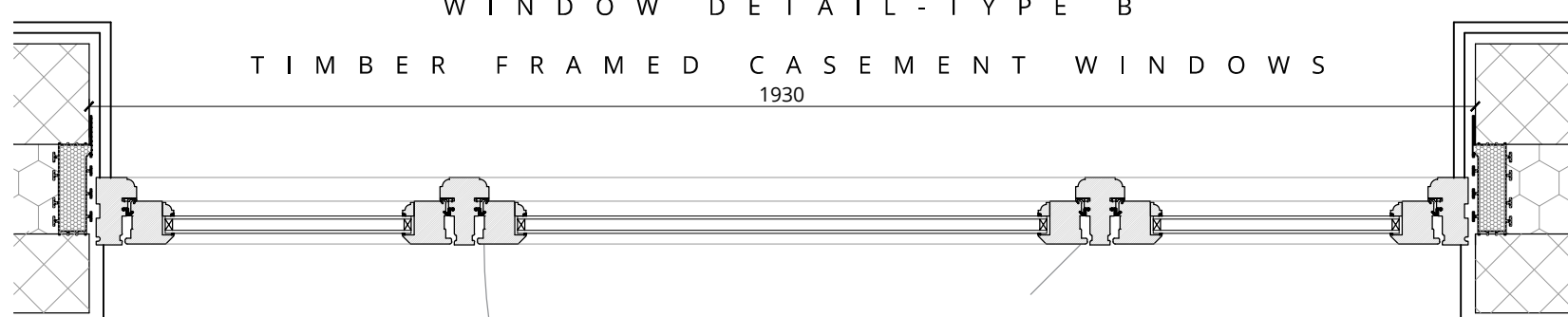
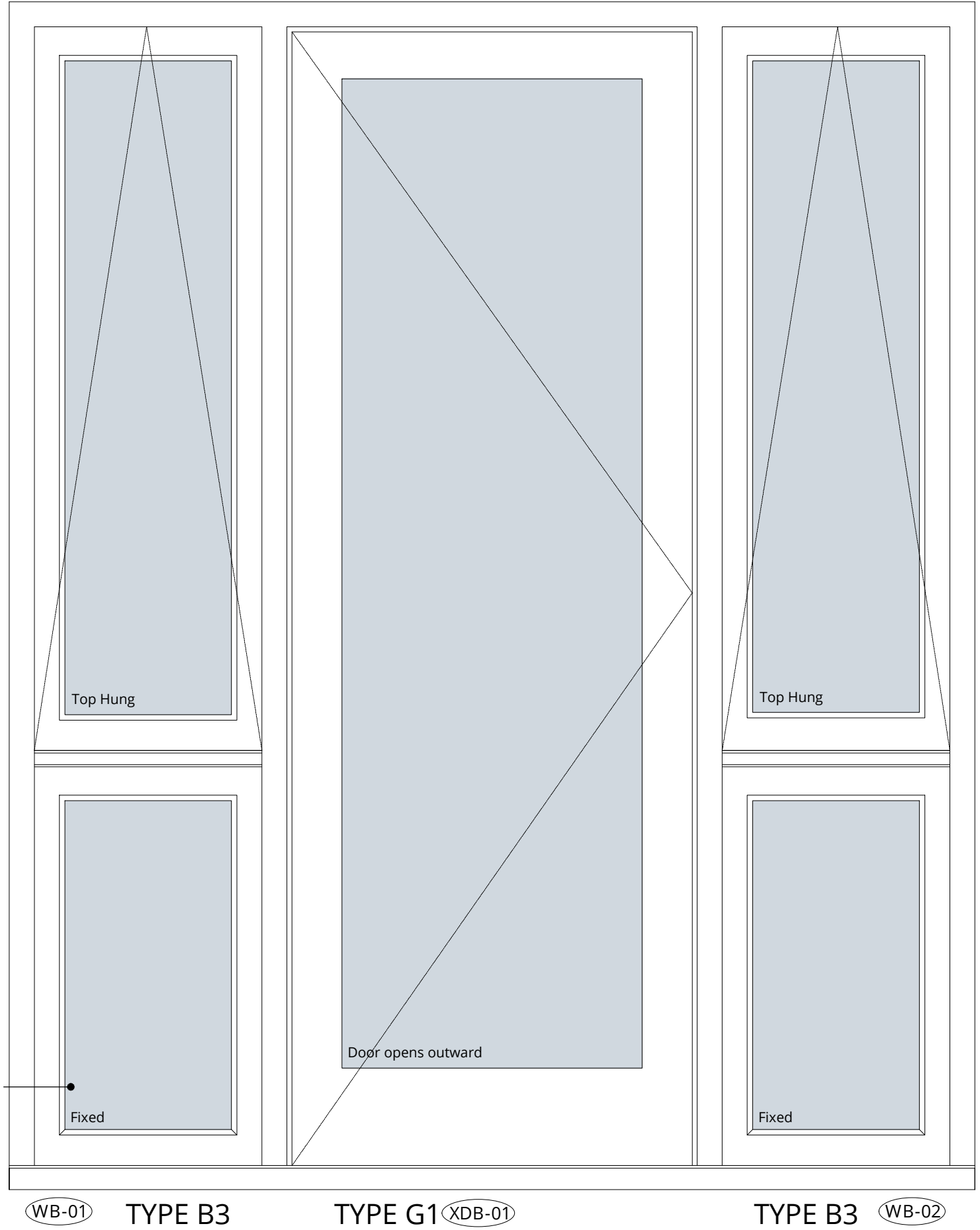
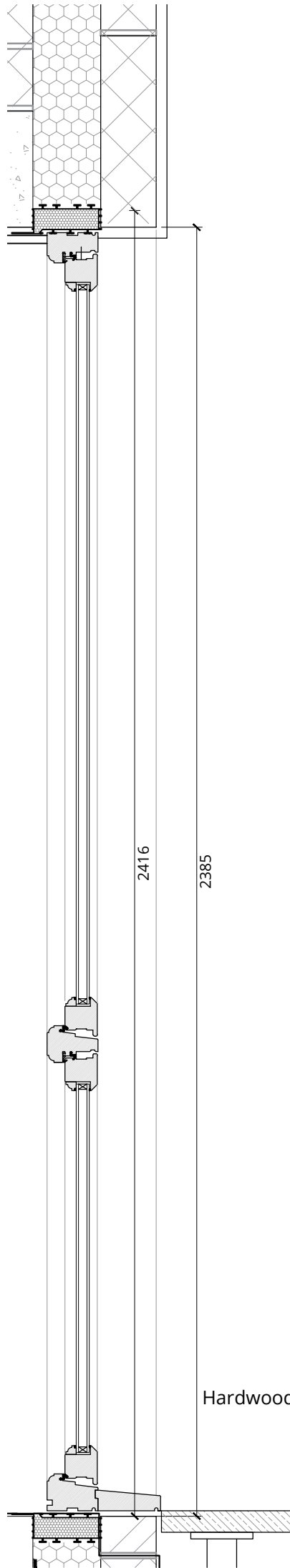

WINDOW DETAIL - TYPE B
 TIMBER FRAMED CASEMENT WINDOWS
 1930



London 16 Lambton Place Notting Hill
 London W11 2SH T +44 (0)20 7229 3125
 Oxford Chandos Yard 83 Bicester Road
 Long Crendon HP18 9EE T +44 (0)1844 203310
 W www.wolffarchitects.co.uk E info@wolffarchitects.co.uk
 This drawing is protected under Copyright and at no time should any portion be reproduced or copied without the permission of the Architect (Design Copyright Act 1968).
 It must not be used for purposes other than that for which it is provided. It is supplied without liability for any errors or omissions. All dimensions to be checked on site.

Rev.	Description	Date	Rev.	Description	Date
0	First issue.	21.02.23			

Project Title					
42 Elsworth Road London NW3 3DL					
Drawing Title					
Proposed Windows - TYPE B3					
Status	Drawn by		Checked by		
CONSTRUCTION					
Scale	Project No.	Work Stage	Dwg. No.	Rev.	
1:10 @ A3	2164	CN	752	0	



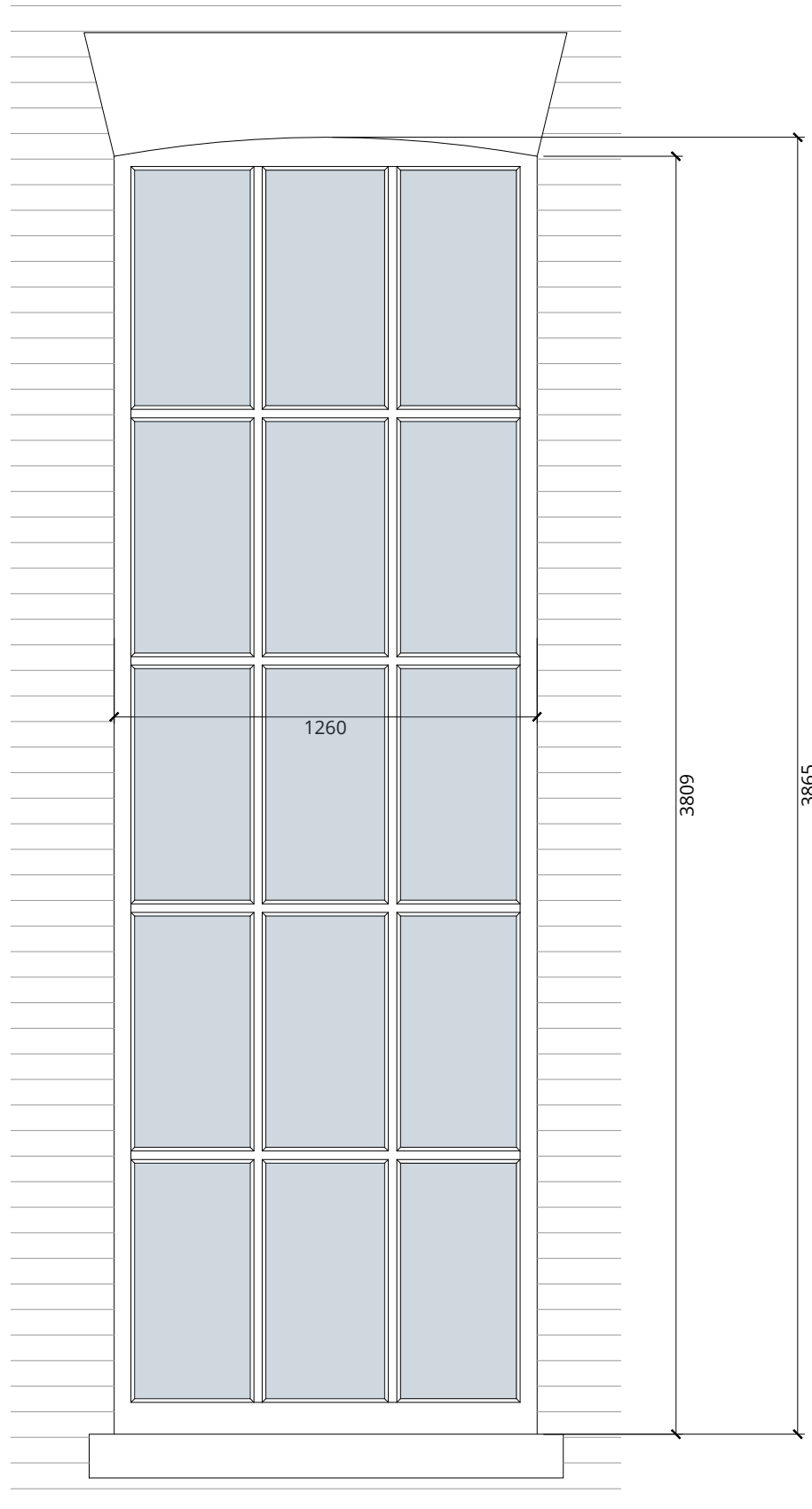

TYPE D (W1-11)

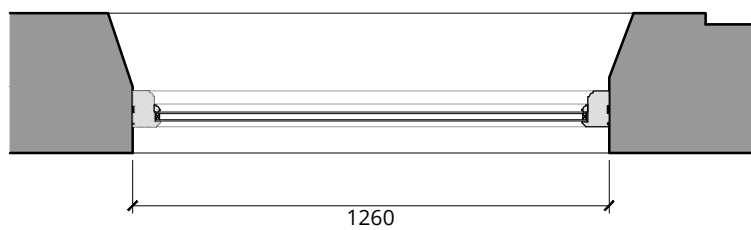

W I N D O W D E T A I L - T Y P E D

T I M B E R F R A M E D F I X E D W I N D O W T O R E P L A C E
E X I S T I N G

Made-to-order, double glazed, high performance, fixed timber casement window for conservation areas. To replace existing window - all dimensions to suit existing

Lomax + Wood or equally approved.

Fully weather-stripped for thermal and acoustic performance.

Three coat white factory finished spray applied micro-porous paint RAL 9010 as standard.

Ironmongery - refer to Interior Designer Ironmongery Schedule

GENERAL NOTES:

- Do not scale from drawings.
- All works to be in accordance with Local Authority's Bylaws.
- The Contractor shall inform the Building Control Inspector of any work that affects the structure of the building, and any other works which require notification, before the work commences.
- Materials and workmanship are to be to the latest British Standards and European Standards where applicable.
- Where this specification refers to a Standard which has been updated the most recent Standard is to be used.
- All mechanical systems are to be designed and installed in accordance with Building Regulations, the latest relevant British or European Standards, and the manufacturer's instructions.
- The contractor shall check all dimensions on site and report any errors. He is to check any discrepancies and report back to the Architect.

NOT FOR CONSTRUCTION:

**ALL DIMENSIONS TO BE CHECKED ON SITE PRIOR TO MANUFACTURE
SHOP DRAWINGS TO BE APPROVED BY ARCHITECT PRIOR TO MANUFACTURE
WINDOW DETAILS SUBJECT TO APPROVAL BY LPA**



London 16 Lambton Place Notting Hill
London W11 2SH T +44 (0)20 7229 3125
Oxford Chandos Yard 83 Bicester Road
Long Crendon HP18 9EE T +44 (0)1844 203310
W www.wolffarchitects.co.uk E info@wolffarchitects.co.uk
This drawing is protected under Copyright and at no time should any portion be reproduced or copied without the permission of the Architect (Design Copyright Act 1968).
It must not be used for purposes other than that for which it is provided. It is supplied without liability for any errors or omissions. All dimensions to be checked on site.

Rev.	Description	Date	Rev.	Description	Date
0	First issue.	21.02.23			

Project Title					
42 Elsworthy Road					
London NW3 3DL					
Drawing Title					
Proposed Windows - TYPE D					
Status		Drawn by		Checked by	
CONSTRUCTION					
Scale	Project No.	Work Stage	Dwg. No.	Rev.	
1:20 @ A3	2164	CN	755	0	



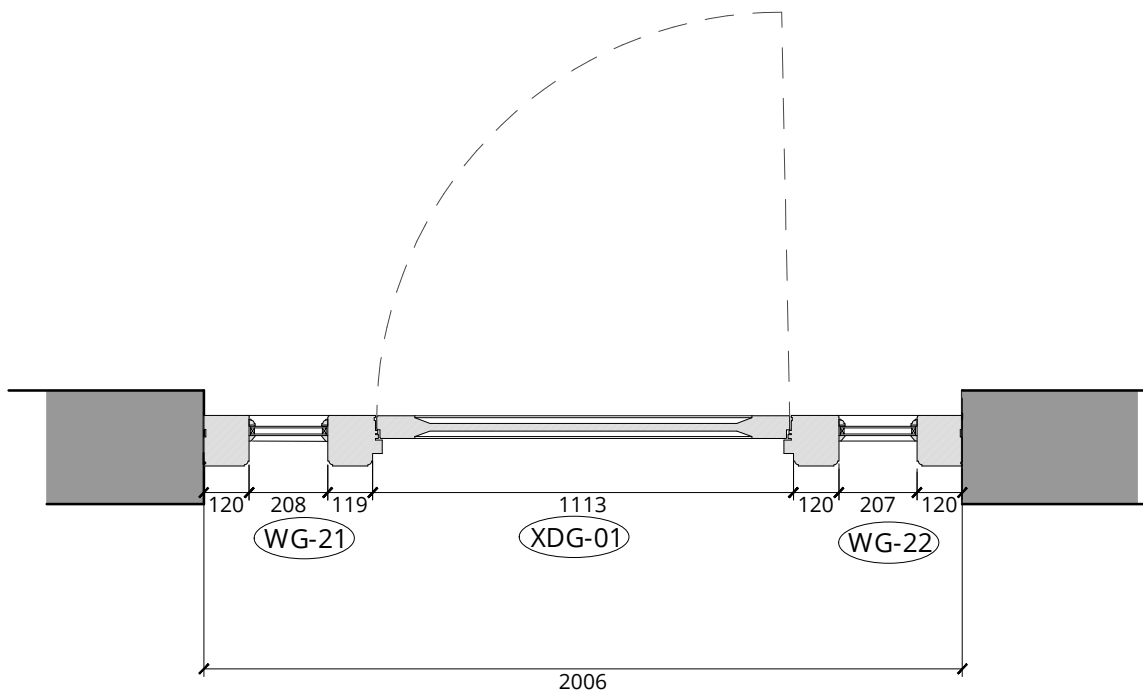
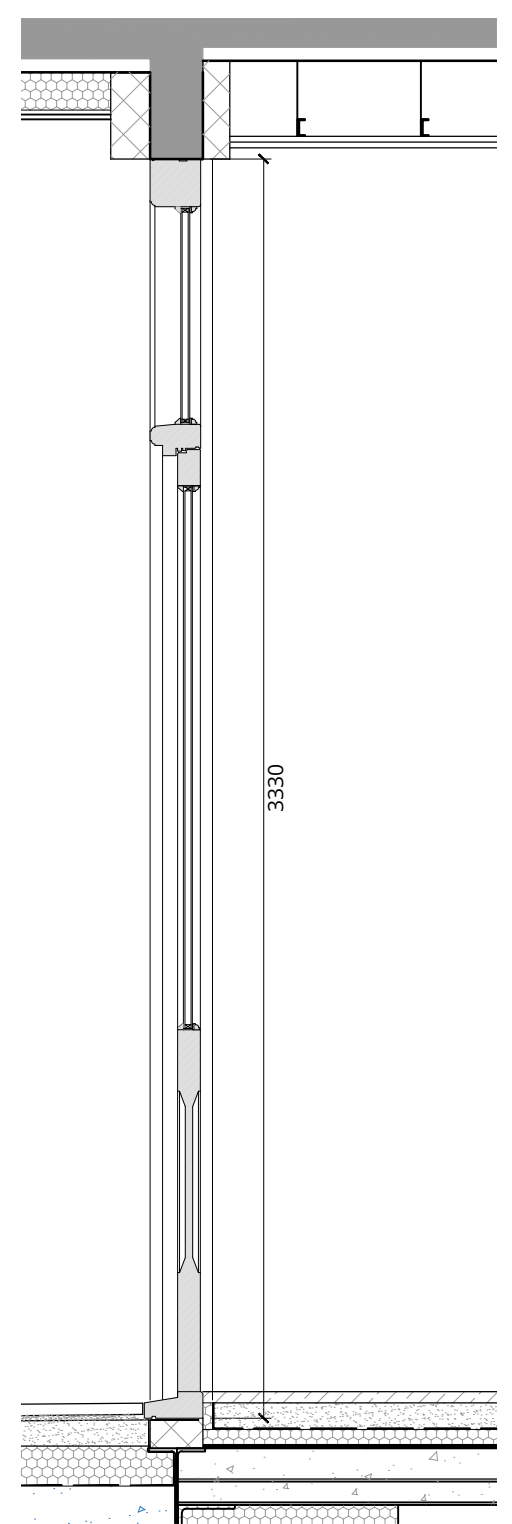

Made-to-order, double glazed, high performance, timber framed door with glazing and fan light Lomax + Wood or equally approved.

D E T A I L - T Y P E E
F R O N T E N T R A N C E D O O R -
(D E S I G N B E I N G D E V E L O P E D)

GENERAL NOTES:

- Do not scale from drawings.
- All works to be in accordance with Local Authority's Bylaws.
- The Contractor shall inform the Building Control Inspector of any work that affects the structure of the building, and any other works which require notification, before the work commences.
- Materials and workmanship are to be to the latest British Standards and European Standards where applicable.
- Where this specification refers to a Standard which has been updated the most recent Standard is to be used.
- All mechanical systems are to be designed and installed in accordance with Building Regulations, the latest relevant British or European Standards, and the manufacturer's instructions.
- The contractor shall check all dimensions on site and report any errors. He is to check any discrepancies and report back to the Architect.

NOT FOR CONSTRUCTION:

**ALL DIMENSIONS TO BE CHECKED ON SITE PRIOR TO MANUFACTURE
SHOP DRAWINGS TO BE APPROVED BY ARCHITECT PRIOR TO MANUFACTURE
WINDOW DETAILS SUBJECT TO APPROVAL BY LPA**



London 16 Lambton Place Notting Hill
London W11 2SH T +44 (0)20 7229 3125
Oxford Chandos Yard 83 Bicester Road
Long Crendon HP18 9EE T +44 (0)1844 203310
W www.wolffarchitects.co.uk E info@wolffarchitects.co.uk
This drawing is protected under Copyright and at no time should any portion be reproduced or copied without the permission of the Architect (Design Copyright Act 1968).
It must not be used for purposes other than that for which it is provided. It is supplied without liability for any errors or omissions. All dimensions to be checked on site.

Rev.	Description	Date	Rev.	Description	Date
0	First issue.	21.02.23			

Project Title					
42 Elsworthy Road London NW3 3DL					
Drawing Title					
Proposed Front Door- TYPE E					
Status		Drawn by		Checked by	
CONSTRUCTION					
Scale	Project No.	Work Stage	Dwg. No.	Rev.	
1:20 @ A3	2164	CN	756	0	





D E T A I L - T Y P E J

F R O N T E N T R A N C E D O O R

GENERAL NOTES:

- Do not scale from drawings.
- All works to be in accordance with Local Authority's Bylaws.
- The Contractor shall inform the Building Control Inspector of any work that affects the structure of the building, and any other works which require notification, before the work commences.
- Materials and workmanship are to be to the latest British Standards and European Standards where applicable.
- Where this specification refers to a Standard which has been updated the most recent Standard is to be used.
- All mechanical systems are to be designed and installed in accordance with Building Regulations, the latest relevant British or European Standards, and the manufacturer's instructions.
- The contractor shall check all dimensions on site and report any errors. He is to check any discrepancies and report back to the Architect.

NOT FOR CONSTRUCTION:

**ALL DIMENSIONS TO BE CHECKED ON SITE PRIOR TO MANUFACTURE
SHOP DRAWINGS TO BE APPROVED BY ARCHITECT PRIOR TO MANUFACTURE
WINDOW DETAILS SUBJECT TO APPROVAL BY LPA**



London 16 Lambton Place Notting Hill
London W11 2SH T +44 (0)20 7229 3125
Oxford Chandos Yard 83 Bicester Road
Long Crendon HP18 9EE T +44 (0)1844 203310
W www.wolffarchitects.co.uk E info@wolffarchitects.co.uk
This drawing is protected under Copyright and at no time should any portion be reproduced or copied without the permission of the Architect (Design Copyright Act 1968).
It must not be used for purposes other than that for which it is provided. It is supplied without liability for any errors or omissions. All dimensions to be checked on site.

Rev.	Description	Date	Rev.	Description	Date
0	First issue.	21.02.23			

Project Title				
42 Elsworthy Road London NW3 3DL				
Drawing Title				
Proposed Front Door- TYPE J				
Status	Drawn by	Checked by		
CONSTRUCTION				
Scale	Project No.	Work Stage	Dwg. No.	Rev.
1:10 @ A3	2164	CN	757	0



Made-to-order, double glazed, high performance, traditionally operated timber framed doors for conservation areas.
 Lomax + Wood or equally approved.
 Fully weather-stripped for thermal and acoustic performance.
 Three coat white factory finished spray applied micro-porous paint RAL 9010 as standard.
 Ironmongery - refer to Interior Designer Ironmongery Schedule

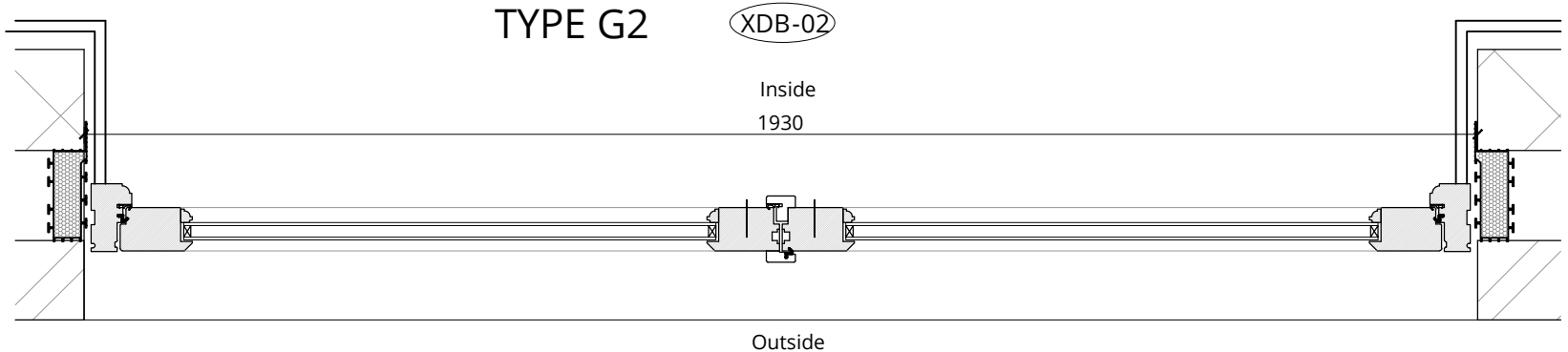
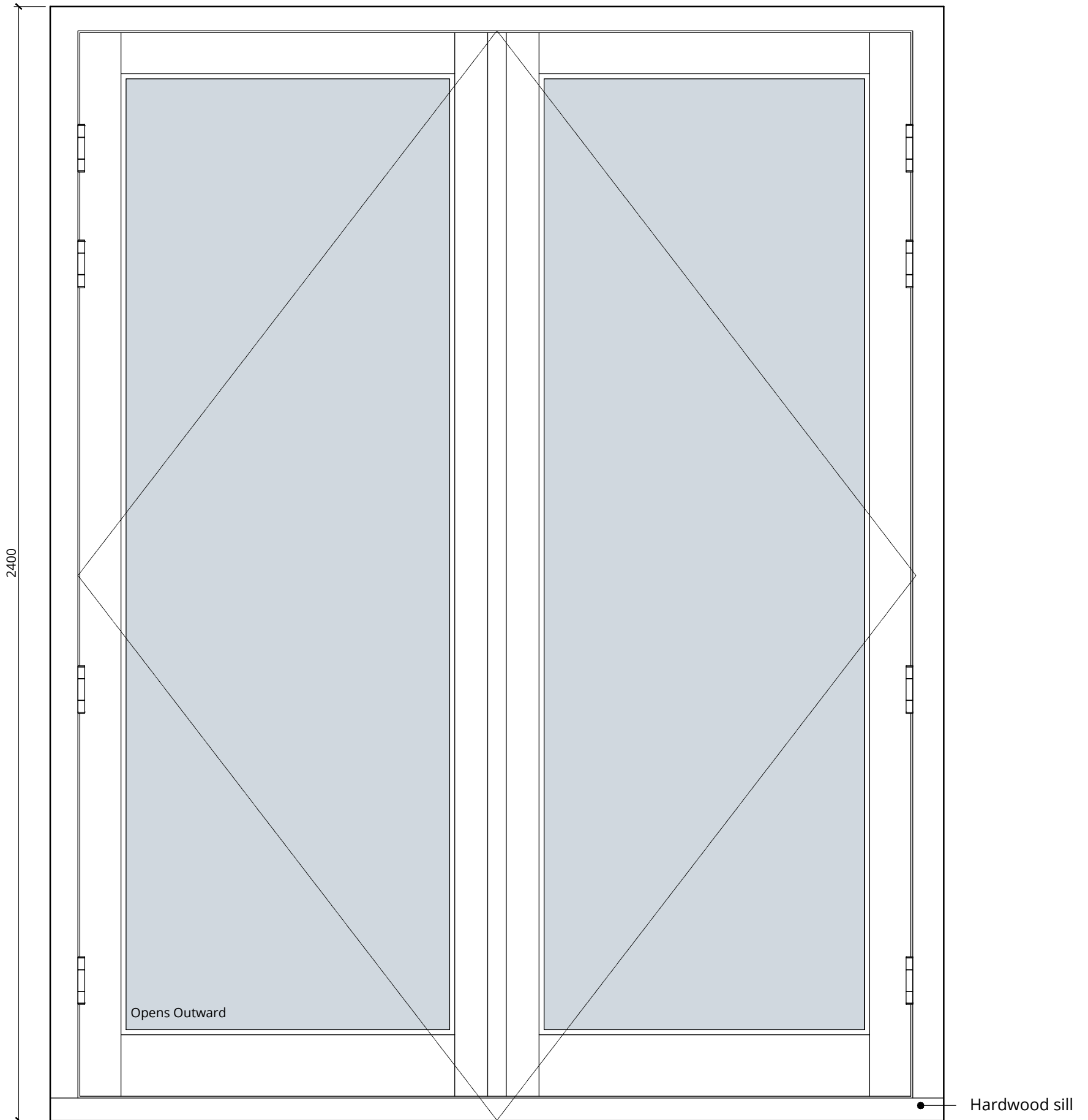
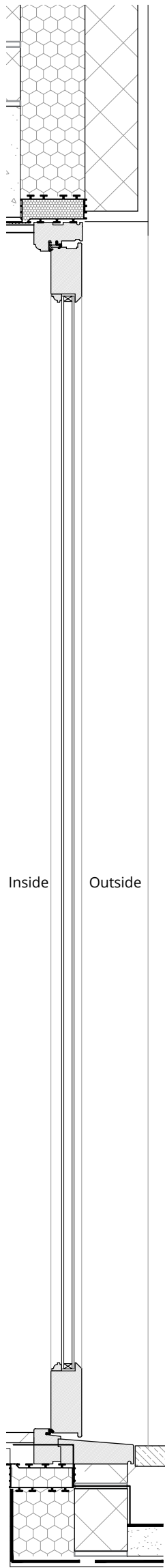

TYPE G2

XDB-02

Inside
1930

Outside

D E T A I L - T Y P E G 2

T I M B E R F R A M E D D O U B L E G L A Z E D D O O R S

NOT FOR CONSTRUCTION:

ALL DIMENSIONS TO BE CHECKED ON SITE PRIOR TO MANUFACTURE
 SHOP DRAWINGS TO BE APPROVED BY ARCHITECT PRIOR TO MANUFACTURE
 WINDOW DETAILS SUBJECT TO APPROVAL BY LPA



London 16 Lambton Place Notting Hill
 London W11 2SH T +44 (0)20 7229 3125
 Oxford Chandos Yard 83 Bicester Road
 Long Crendon HP18 9EE T +44 (0)1844 203310
 W www.wolffarchitects.co.uk E info@wolffarchitects.co.uk
 This drawing is protected under Copyright and at no time should any
 portion be reproduced or copied without the permission of the
 Architect (Design Copyright Act 1968).
 It must not be used for purposes other than that for which it is
 provided. It is supplied without liability for any errors or omissions.
 All dimensions to be checked on site.

Rev.	Description	Date	Rev.	Description	Date
0	First issue.	21.02.23			

Project Title					
42 Elsworth Road					
London NW3 3DL					
Drawing Title					
Proposed External Doors - TYPE G2					
Status	Drawn by		Checked by		
CONSTRUCTION					
Scale	Project No.	Work Stage	Dwg. No.	Rev.	
1:10 @ A3	2164	CN	758	0	



Made-to-order, double glazed, high performance, traditionally operated timber framed door for conservation areas.
 All lower ground and ground floor glazing to be toughened safety glass for security.
 Refer to details for dimensions of all timber members.
 Lomax + Wood or equally approved. Sizes vary - refer to schedule.
 Fully weather-stripped for thermal and acoustic performance. Three coat white factory finished spray applied micro-porous paint RAL 9010 as standard.
 Ironmongery - refer to Interior Designer Ironmongery Schedule

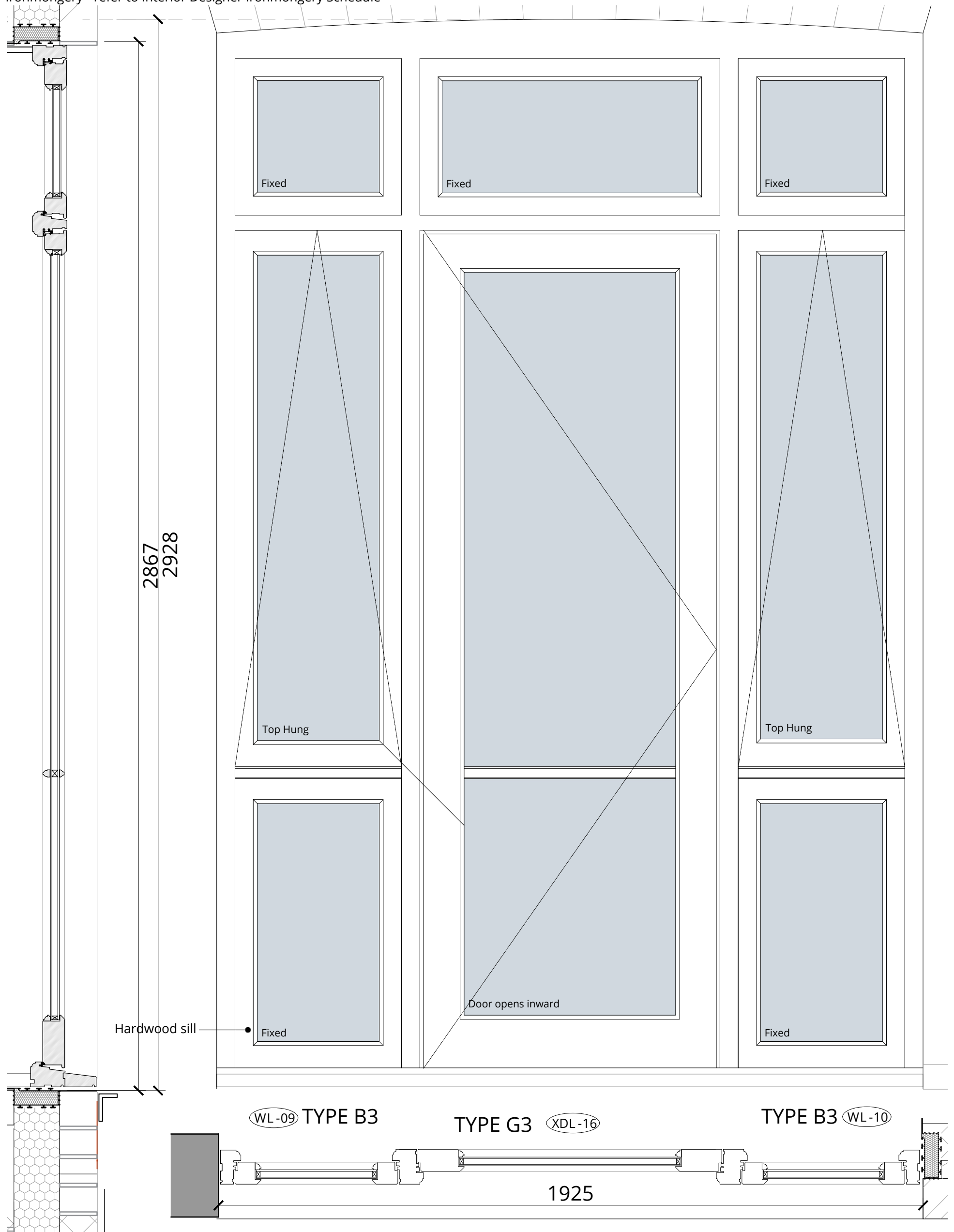

DETAIL - TYPE G
 TIMBER FRAMED DOOR WITH DOUBLE GLAZING



London 16 Lambton Place Notting Hill
 London W11 2SH T +44 (0)20 7229 3125
 Oxford Chandos Yard 83 Bicester Road
 Long Crendon HP18 9EE T +44 (0)1844 203310
 W www.wolffarchitects.co.uk E info@wolffarchitects.co.uk
 This drawing is protected under Copyright and at no time should any
 portion be reproduced or copied without the permission of the
 Architect (Design Copyright Act 1968).
 It must not be used for purposes other than that for which it is
 provided. It is supplied without liability for any errors or omissions.
 All dimensions to be checked on site.

Rev.	Description	Date	Rev.	Description	Date
0	First issue.	21.02.23			

Project Title			
42 Elsworth Road London NW3 3DL			
Drawing Title			
Proposed Window TYPE G3			
Status	Drawn by	Checked by	
CONSTRUCTION			
Scale	Project No.	Work Stage	Dwg. No.
1:20 @ A3	2164	CN	759 - 0



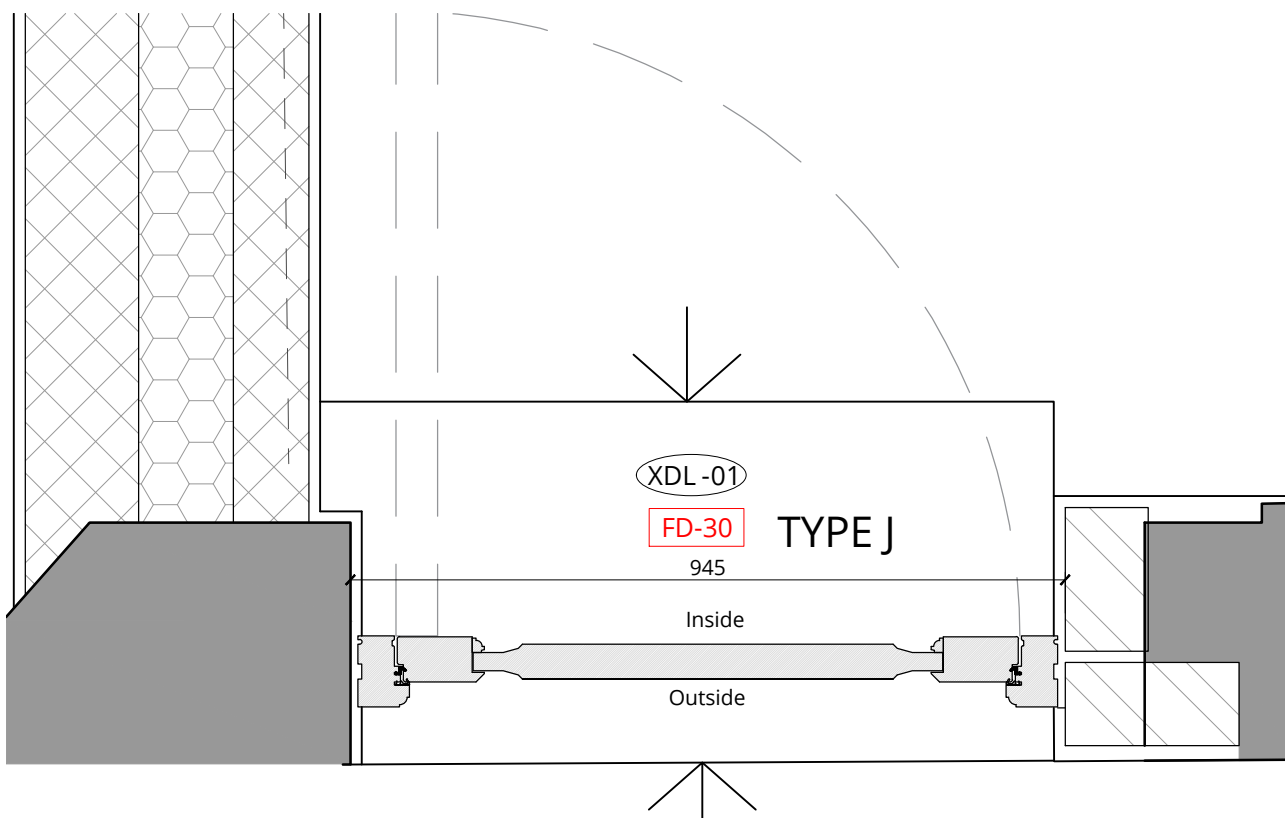
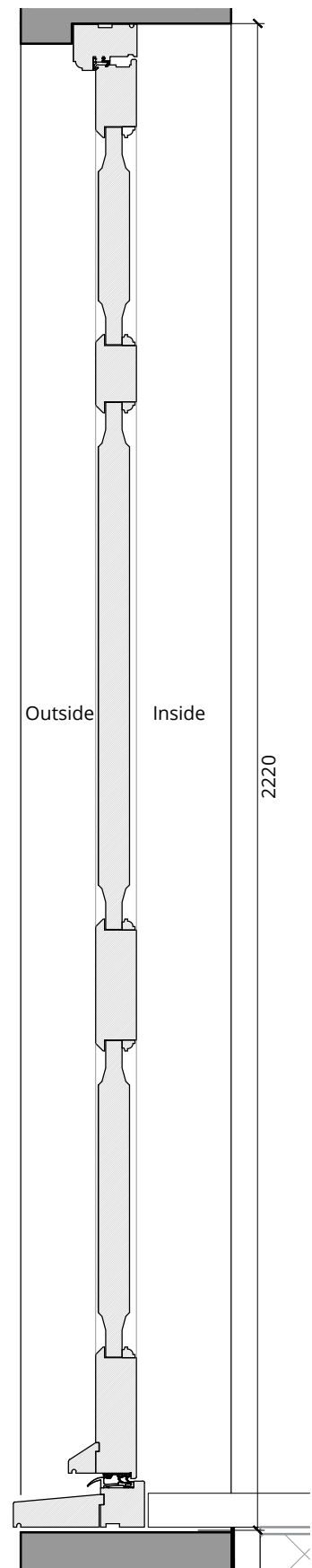
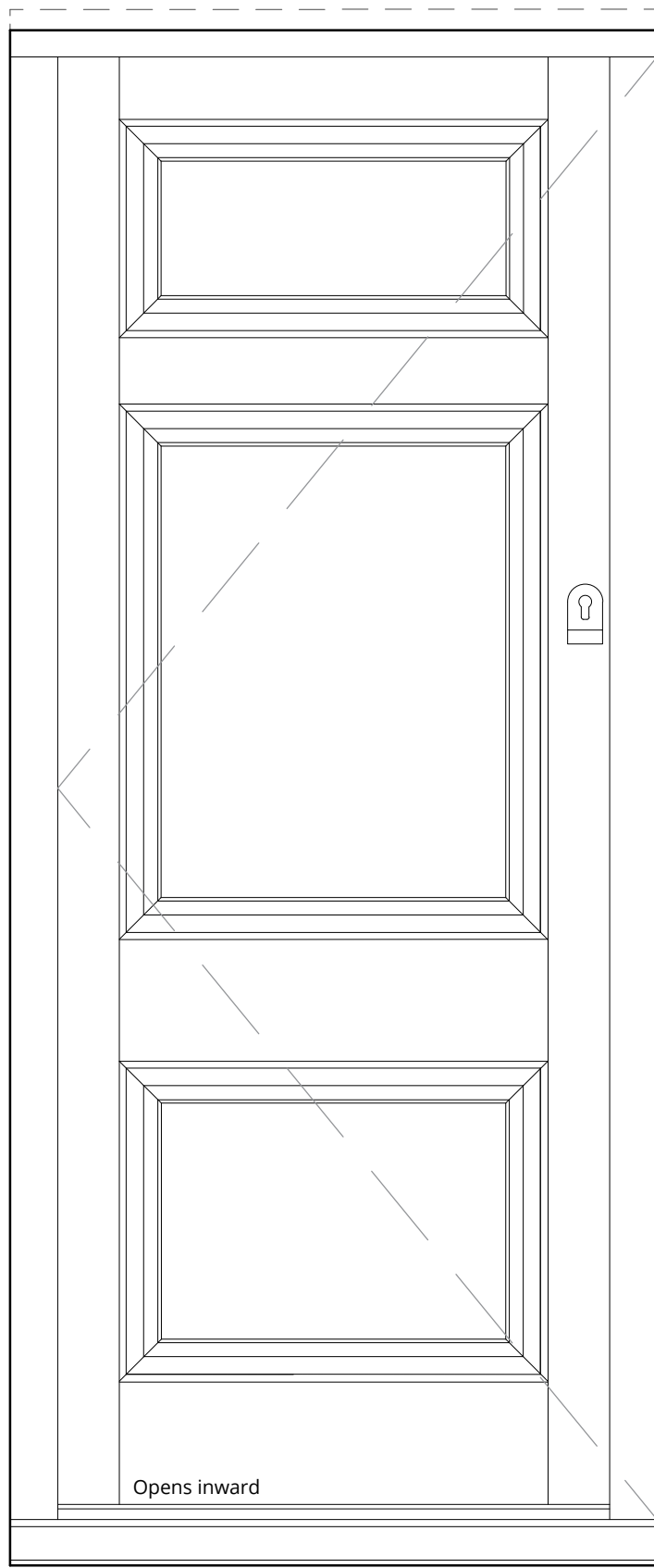

DETAIL - TYPE J
TIMBER PANELED DOOR

NOT FOR CONSTRUCTION:
 ALL DIMENSIONS TO BE CHECKED ON SITE PRIOR TO MANUFACTURE
 SHOP DRAWINGS TO BE APPROVED BY ARCHITECT PRIOR TO MANUFACTURE
 WINDOW DETAILS SUBJECT TO APPROVAL BY LPA



London 16 Lambton Place Notting Hill
 London W11 2SH T +44 (0)20 7229 3125
 Oxford Chandos Yard 83 Bicester Road
 Long Crendon HP18 9EE T +44 (0)1844 203310
 W www.wolffarchitects.co.uk E info@wolffarchitects.co.uk
 This drawing is protected under Copyright and at no time should any
 portion be reproduced or copied without the permission of the
 Architect (Design Copyright Act 1968).
 It must not be used for purposes other than that for which it is
 provided. It is supplied without liability for any errors or omissions.
 All dimensions to be checked on site.

Rev.	Description	Date	Rev.	Description	Date
0	First issue.	21.02.23			

Project Title			
42 Elsworthy Road London NW3 3DL			
Drawing Title			
Proposed External Doors TYPE J			
Status	Drawn by	Checked by	
CONSTRUCTION			
Scale	Project No.	Work Stage	Dwg. No. Rev.
1:10 @ A3	2164	CN	762 - 0



Rev.	Description	Date	Rev.	Description	Date
0	First issue.	21.02.23			

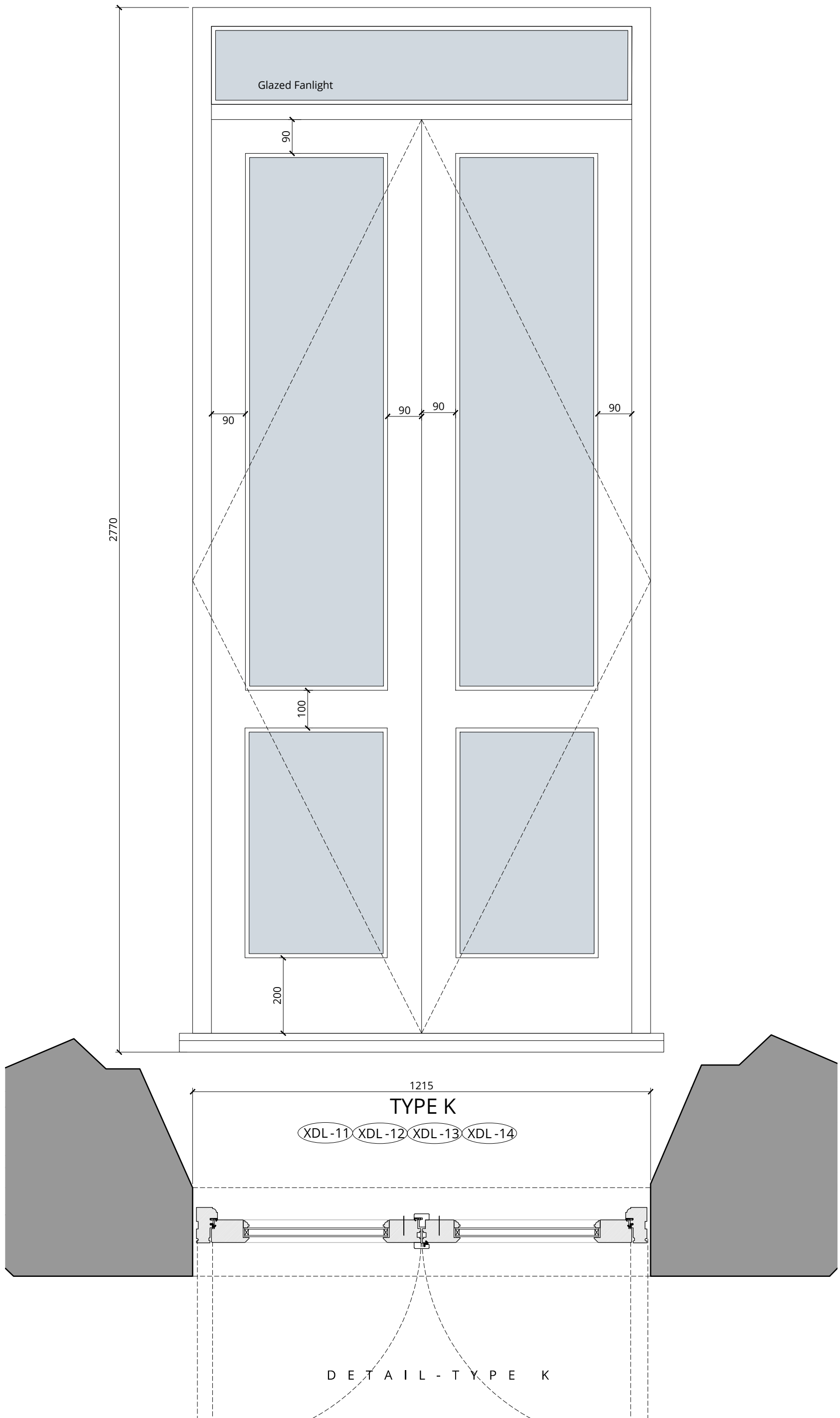

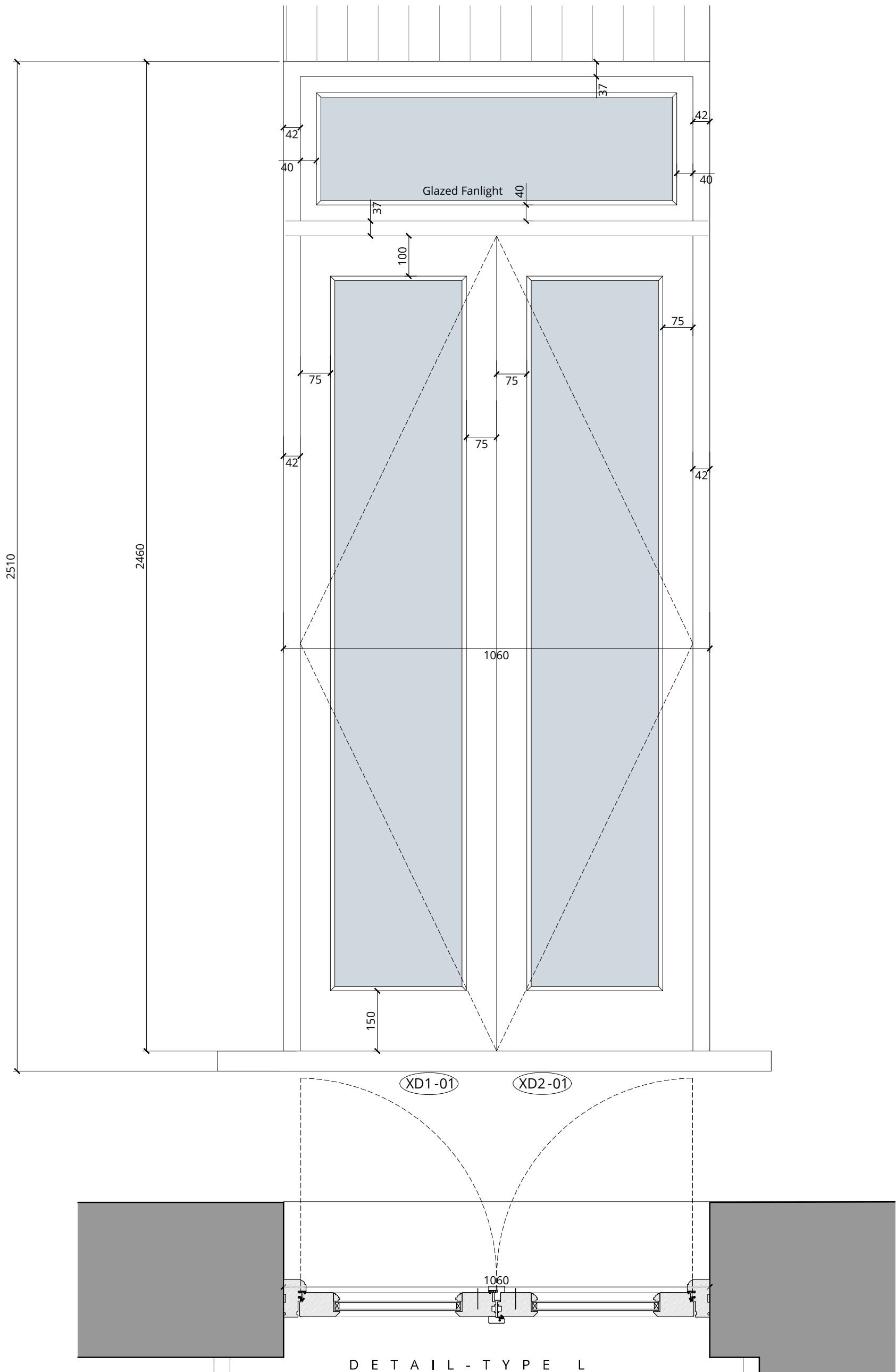

GENERAL NOTES:

- Do not scale from drawings.
- All works to be in accordance with Local Authority's Bylaws.
- The Contractor shall inform the Building Control Inspector of any work that affects the structure of the building, and any other works which require notification, before the work commences.
- Materials and workmanship are to be to the latest British Standards and European Standards where applicable.
- Where this specification refers to a Standard which has been updated the most recent Standard is to be used.
- All mechanical systems are to be designed and installed in accordance with Building Regulations, the latest relevant British or European Standards, and the manufacturer's instructions.
- The contractor shall check all dimensions on site and report any errors. He is to check any discrepancies and report back to the Architect.

NOT FOR CONSTRUCTION:

**ALL DIMENSIONS TO BE CHECKED ON SITE PRIOR TO MANUFACTURE
SHOP DRAWINGS TO BE APPROVED BY ARCHITECT PRIOR TO MANUFACTURE
WINDOW DETAILS SUBJECT TO APPROVAL BY LPA**



London 16 Lambton Place Notting Hill
London W11 2SH T +44 (0)20 7229 3125
Oxford Chandos Yard 83 Bicester Road
Long Crendon HP18 9EE T +44 (0)1844 203310
W www.wolffarchitects.co.uk E info@wolffarchitects.co.uk
This drawing is protected under Copyright and at no time should any portion be reproduced or copied without the permission of the Architect (Design Copyright Act 1968).
It must not be used for purposes other than that for which it is provided. It is supplied without liability for any errors or omissions. All dimensions to be checked on site.

Rev.	Description	Date	Rev.	Description	Date
0	First issue.	21.02.23			

Project Title					
42 Elsworthy Road London NW3 3DL					
Drawing Title					
Proposed External Doors TYPE L					
Status	Project No.	Work Stage	Dwg. No.	Rev.	Checked by
CONSTRUCTION					
Scale	Project No.	Work Stage	Dwg. No.	Rev.	
1:10 @ A3	2164	CN	764	0	



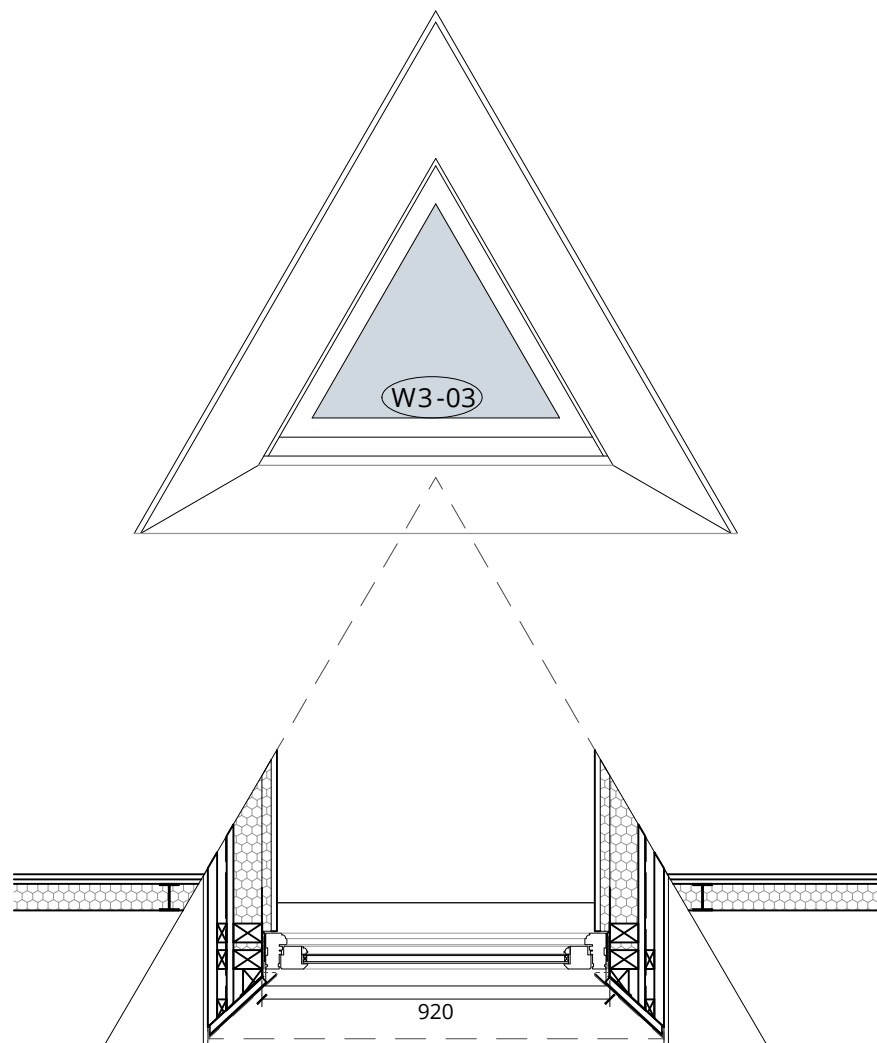

DETAIL - TYPE N
DORMER WINDOW

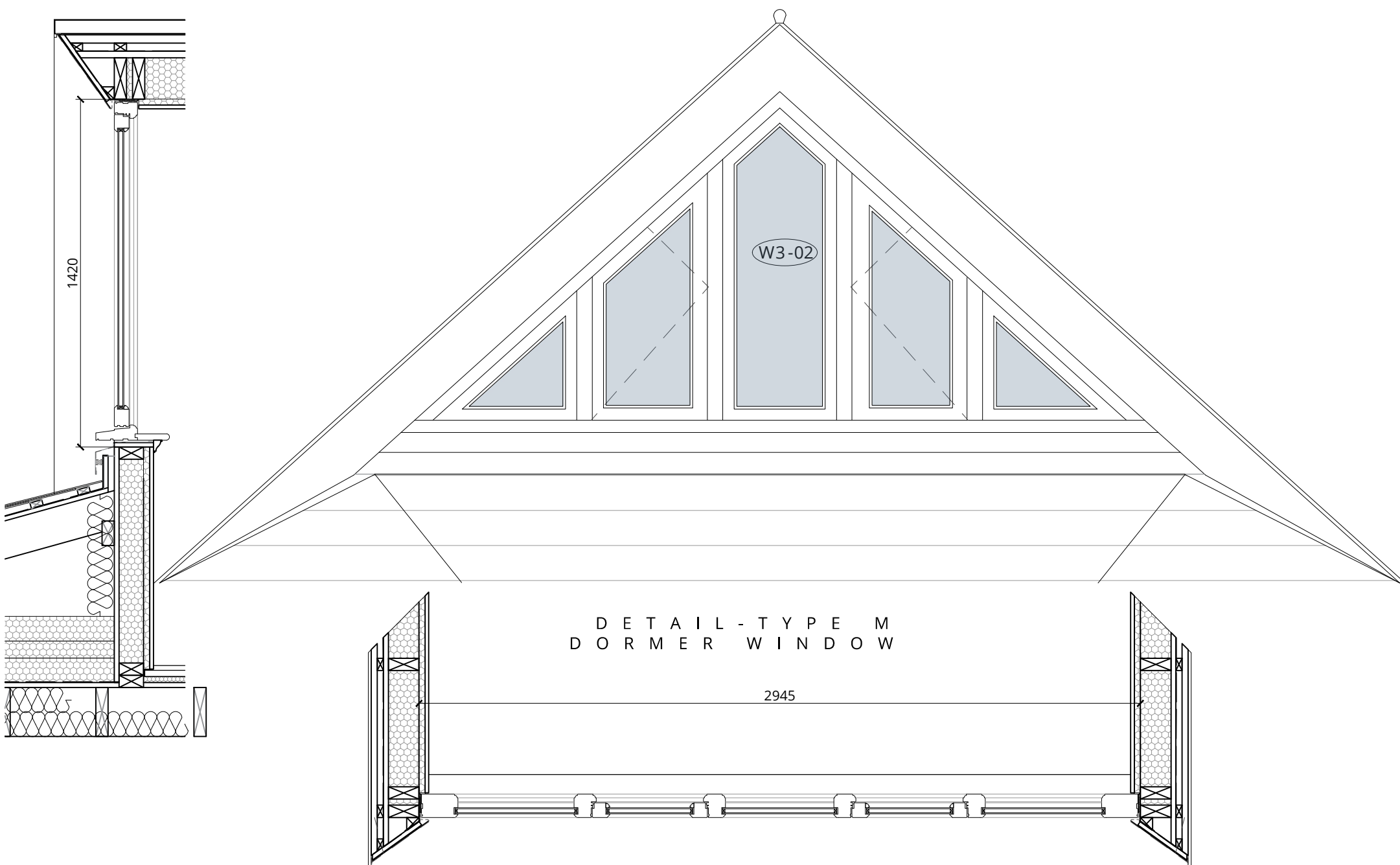

DETAIL - TYPE M
DORMER WINDOW

GENERAL NOTES:

- Do not scale from drawings.
- All works to be in accordance with Local Authority's Bylaws.
- The Contractor shall inform the Building Control Inspector of any work that affects the structure of the building, and any other works which require notification, before the work commences.
- Materials and workmanship are to be to the latest British Standards and European Standards where applicable.
- Where this specification refers to a Standard which has been updated the most recent Standard is to be used.
- All mechanical systems are to be designed and installed in accordance with Building Regulations, the latest relevant British or European Standards, and the manufacturer's instructions.
- The contractor shall check all dimensions on site and report any errors. He is to check any discrepancies and report back to the Architect.

NOT FOR CONSTRUCTION:

**ALL DIMENSIONS TO BE CHECKED ON SITE PRIOR TO MANUFACTURE
SHOP DRAWINGS TO BE APPROVED BY ARCHITECT PRIOR TO MANUFACTURE
WINDOW DETAILS SUBJECT TO APPROVAL BY LPA**



London 16 Lambton Place Notting Hill
London W11 2SH T +44 (0)20 7229 3125
Oxford Chandos Yard 83 Bicester Road
Long Crendon HP18 9EE T +44 (0)1844 203310
W www.wolffarchitects.co.uk E info@wolffarchitects.co.uk
This drawing is protected under Copyright and at no time should any portion be reproduced or copied without the permission of the Architect (Design Copyright Act 1968).
It must not be used for purposes other than that for which it is provided. It is supplied without liability for any errors or omissions. All dimensions to be checked on site.

Rev.	Description	Date	Rev.	Description	Date
0	First issue.	21.02.23			

Project Title					
42 Elsworthy Road London NW3 3DL					
Drawing Title					
Proposed Windows TYPE N & M					
Status		Drawn by		Checked by	
CONSTRUCTION					
Scale	Project No.	Work Stage	Dwg. No.	Rev.	
1:20 @ A3	2164	CN	765	0	



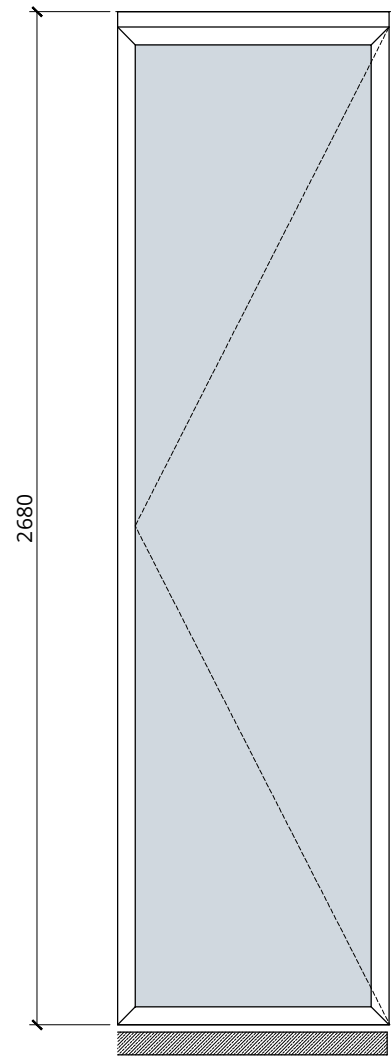
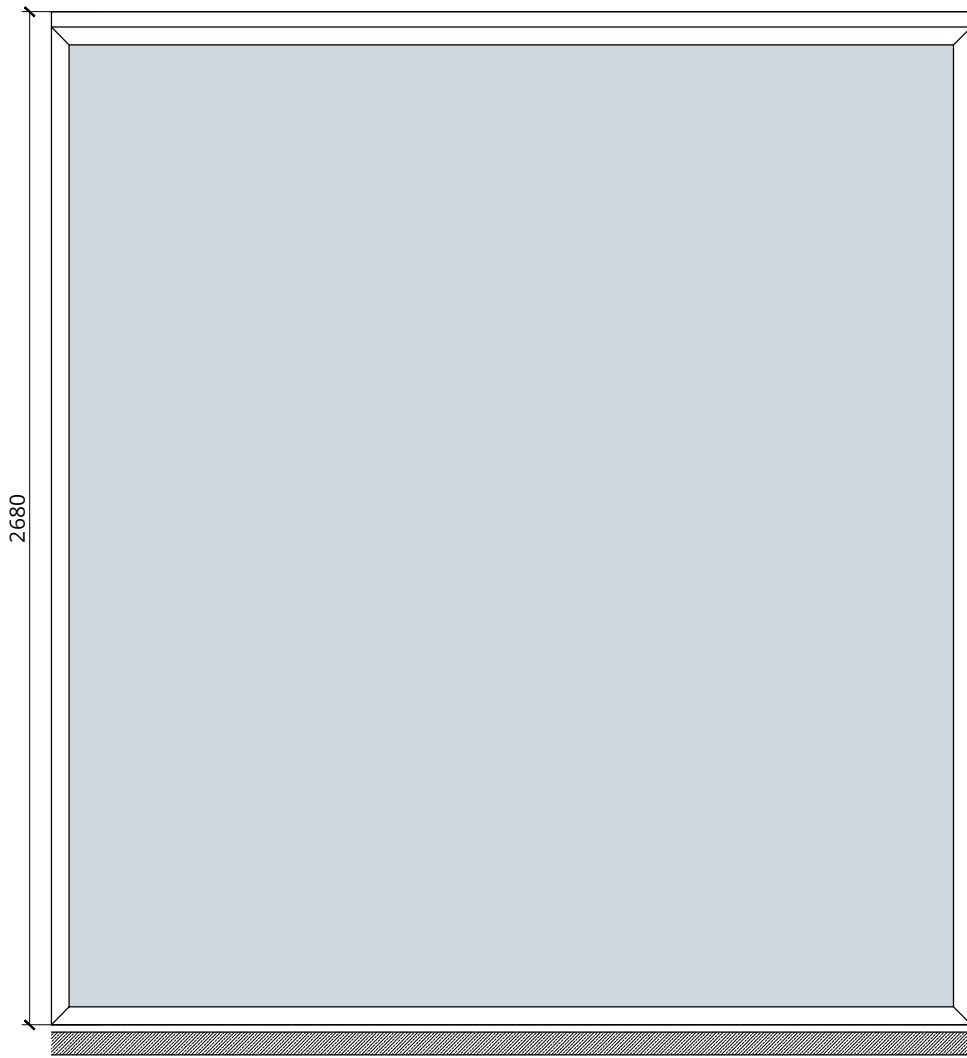
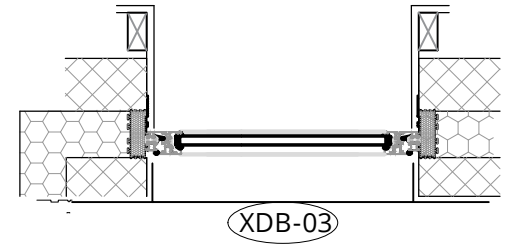
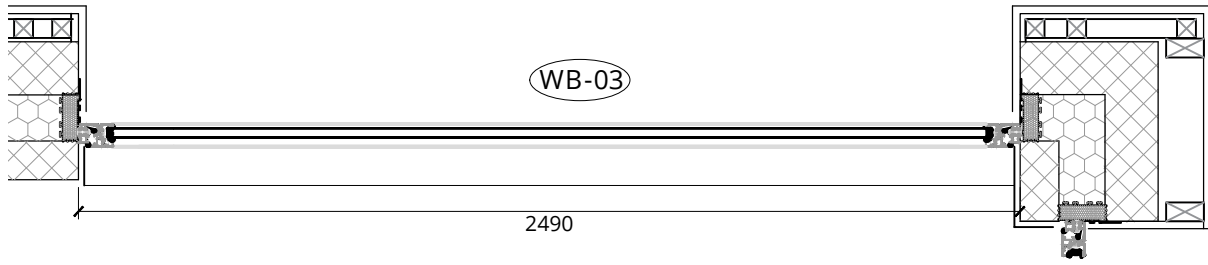

DETAIL - TYPE T1
METAL FRAME WINDOW

DETAIL - TYPE T2
METAL FRAME DOOR

GENERAL NOTES:

- Do not scale from drawings.
- All works to be in accordance with Local Authority's Bylaws.
- The Contractor shall inform the Building Control Inspector of any work that affects the structure of the building, and any other works which require notification, before the work commences.
- Materials and workmanship are to be to the latest British Standards and European Standards where applicable.
- Where this specification refers to a Standard which has been updated the most recent Standard is to be used.
- All mechanical systems are to be designed and installed in accordance with Building Regulations, the latest relevant British or European Standards, and the manufacturer's instructions.
- The contractor shall check all dimensions on site and report any errors. He is to check any discrepancies and report back to the Architect.

NOT FOR CONSTRUCTION:

**ALL DIMENSIONS TO BE CHECKED ON SITE PRIOR TO MANUFACTURE
SHOP DRAWINGS TO BE APPROVED BY ARCHITECT PRIOR TO MANUFACTURE
WINDOW DETAILS SUBJECT TO APPROVAL BY LPA**



London 16 Lambton Place Notting Hill
London W11 2SH T +44 (0)20 7229 3125
Oxford Chandos Yard 83 Bicester Road
Long Crendon HP18 9EE T +44 (0)1844 203310
W www.wolffarchitects.co.uk E info@wolffarchitects.co.uk
This drawing is protected under Copyright and at no time should any portion be reproduced or copied without the permission of the Architect (Design Copyright Act 1968).
It must not be used for purposes other than that for which it is provided. It is supplied without liability for any errors or omissions. All dimensions to be checked on site.

Rev.	Description	Date	Rev.	Description	Date
0	First issue.	21.02.23			

Project Title					
42 Elsworthy Road London NW3 3DL					
Drawing Title					
Proposed TYPE T1 & T2					
Status	Drawn by		Checked by		
CONSTRUCTION					
Scale	Project No.	Work Stage	Dwg. No.	Rev.	
1:20 @ A3	2164	CN	766	0	

