

NOTES

Copyright Carbogno Ceneda Architects.

No implied license exists. This drawing should not be used to calculate areas for the purposes of valuation. All dimensions to be checked on site by the contractor and such dimensions to be their responsibility.

This drawing is to be read in conjunction with all other contract documents and specifications and all other consultants drawings. All levels and dimensions should be checked on site.

All work must comply with relevant British Standards and Building Regulations requirements. Drawing errors and omissions to be reported to the architect.

REV - 30.03.2023  
- DISCHARGE OF CONDITION APPLICATION

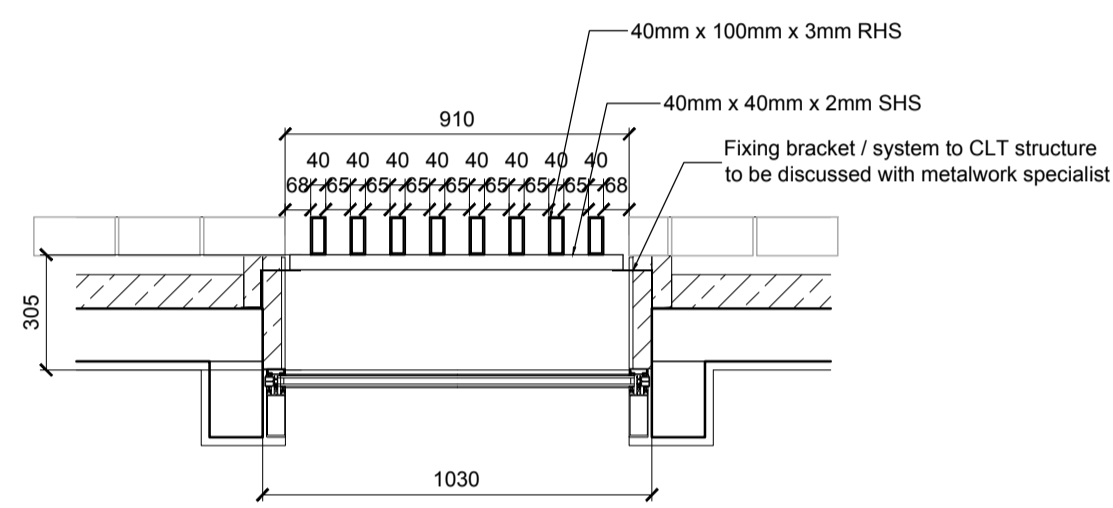

PLAN (Floors Above)

CW	03	04
MF	01	02

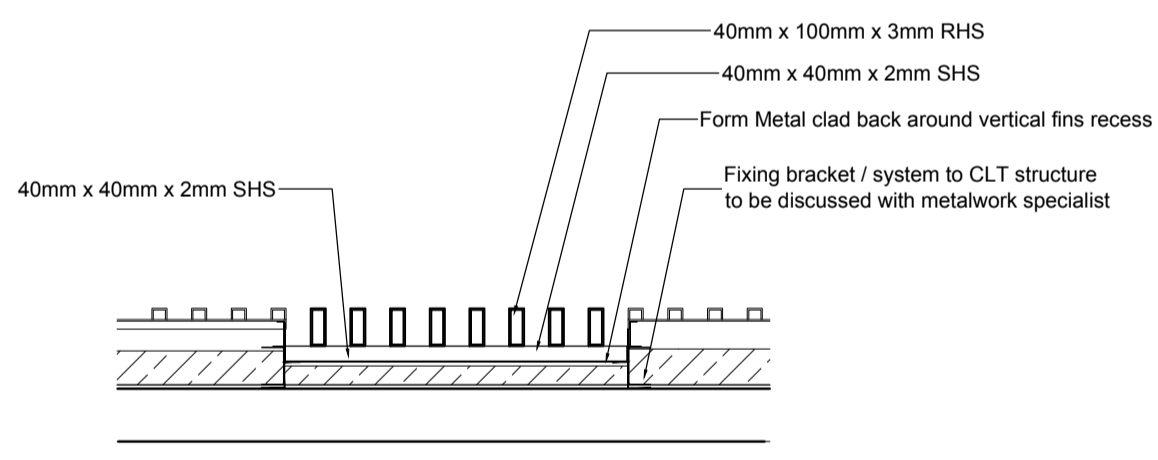

PLAN (Ground Floor)

MF	01	02
----	----	----

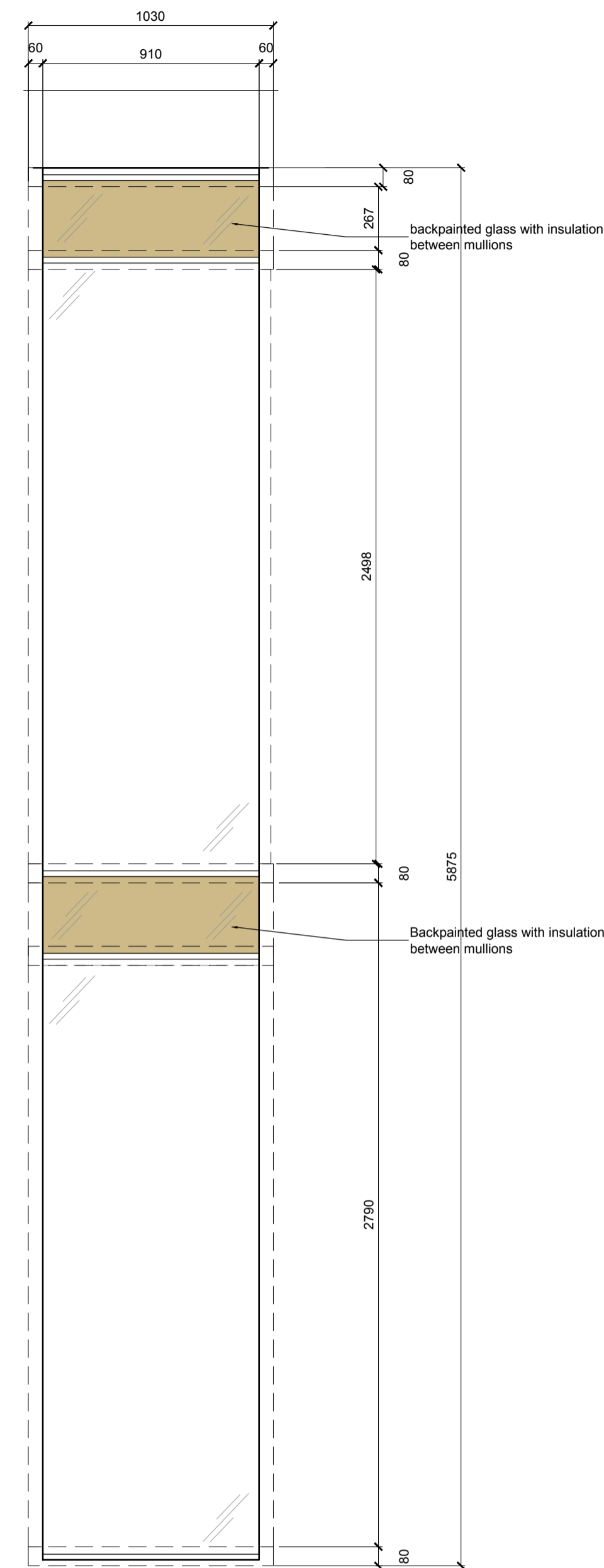

ELEVATION OF GLAZING SHOWN WITHOUT FINS

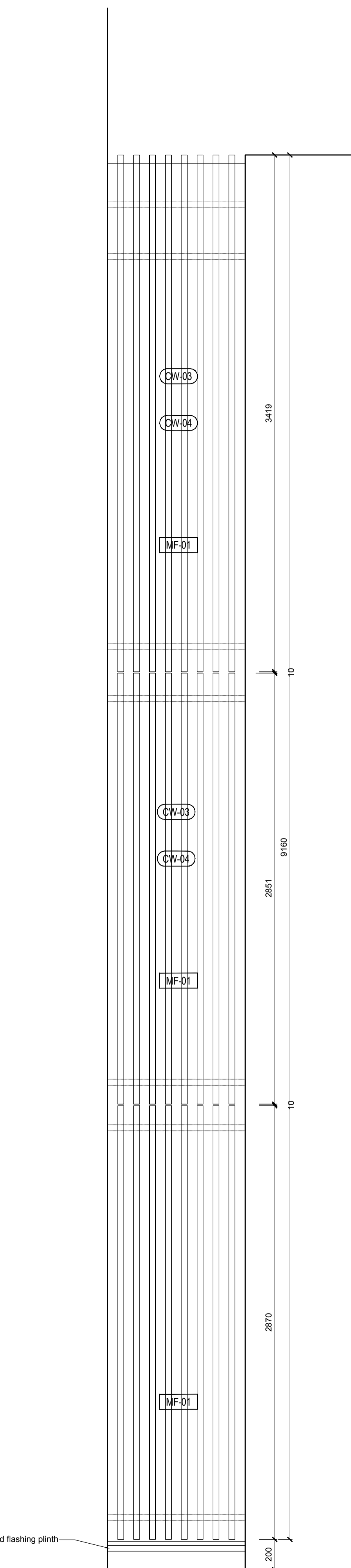

ELEVATION OF GLAZING SHOWING FINS

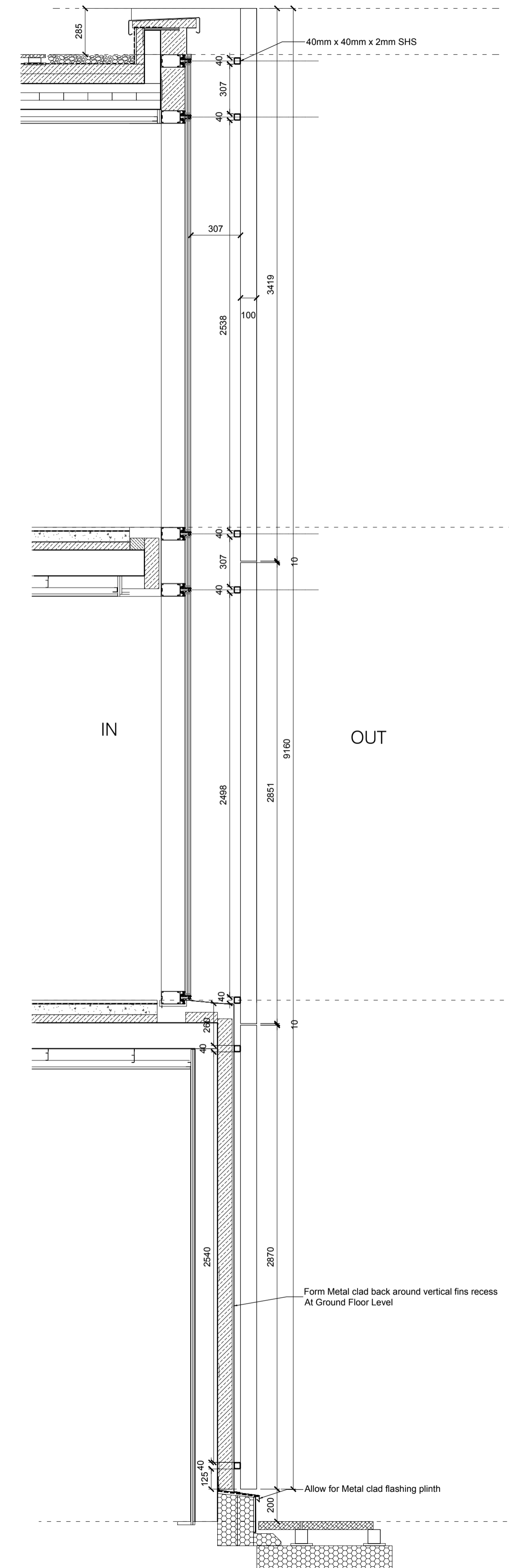

SECTION

Project Ref. No.	2113
Client	BROXWOOD VIEW LIMITED
Date	JANUARY 2023
Scale	1:20 @ A1
Project	BROXWOOD VIEW, 29 ST EDMUNDS TERRACE, LONDON NW8 7QH
Drawing Name	GLAZING WITH FINS DETAIL
Drawing No.	P.548
Rev.	
Drawn	CF
Approved	AC
Signed	
CARBOGNO CENEDA ARCHITECTS 4th ANFILL ROAD, LONDON N15 4BA TEL: 07890 586 884 INFO@CARBOGNOCENEDA.COM	
© COPYRIGHT NOT TO BE REPRODUCED OR USED WITHOUT PERMISSION	