the super lux bifold



sieger®

the super lux bifold

It is now possible to create thermally broken, aluminium bifolding doors up to 5m tall with the Sieger Super Lux Bifold Door. Based on the ultra slim Sieger Lux Bifold, the upgraded version can achieve extended heights of 3m to 5m thanks to the inclusion of a stabilising wind profile. When specified in an open corner configuration, it is possible to have the same or a different number of track meeting.

sightlines	vent + frame	44mm
	meeting profile	144mm
glass	max thickness	32mm
	typical spec	DGU
max sizes	sliding pane	1200mm wide x 5000mm tall
	pane weight	260kg
	no. of panes	no maximum
performance	uw value	from 1.6 W/m ² K*
	air permeability EN12207	Class 4
	water tightness EN12208	Class 7A - 9A
configurations	inward or outward opening	with traffic door / biparting / corner opening
ironmongery	rails	stainless steel
	wheels	stainless steel
	locking	up to 3 point locking

*uw values must be calculated per project.

Opening corners can be with the same or different track numbers meeting one another. 'Pass doors' attached to the bifolding stack are not possible. Pass doors can be wall mounted.

the super lux bifold

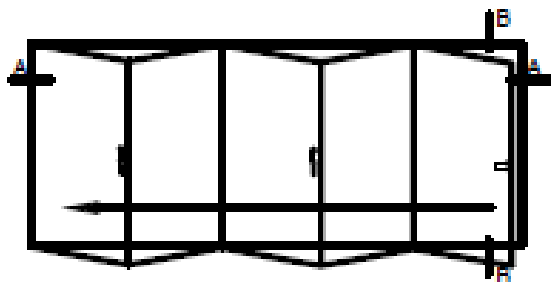
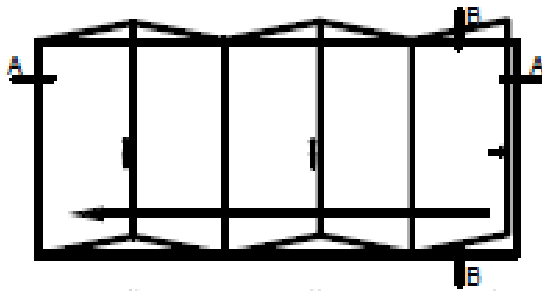
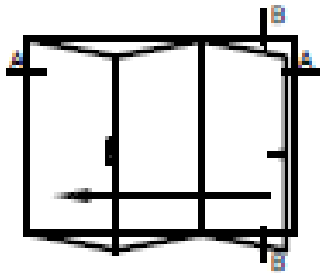
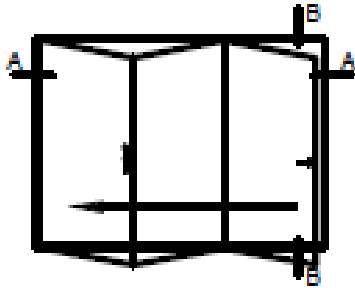

Some example configurations of both 3-pane and 5-pane bifolds, inwards and outwards opening.

the super lux bifold

CONVEX CORNER

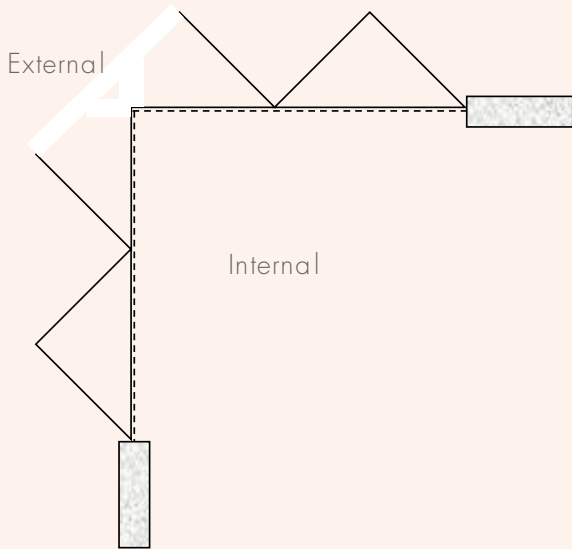

* Opening corner Sieger Lux Bifolds are available in an outward opening configuration on convex corners.

CONCAVE CORNER

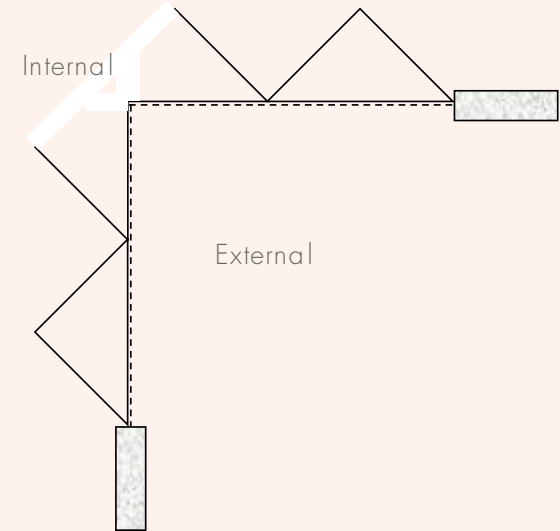

* Opening corner Sieger Lux Bifolds are available in an inward opening configuration on concave corners.

the super lux bifold

horizontal section, meeting stile

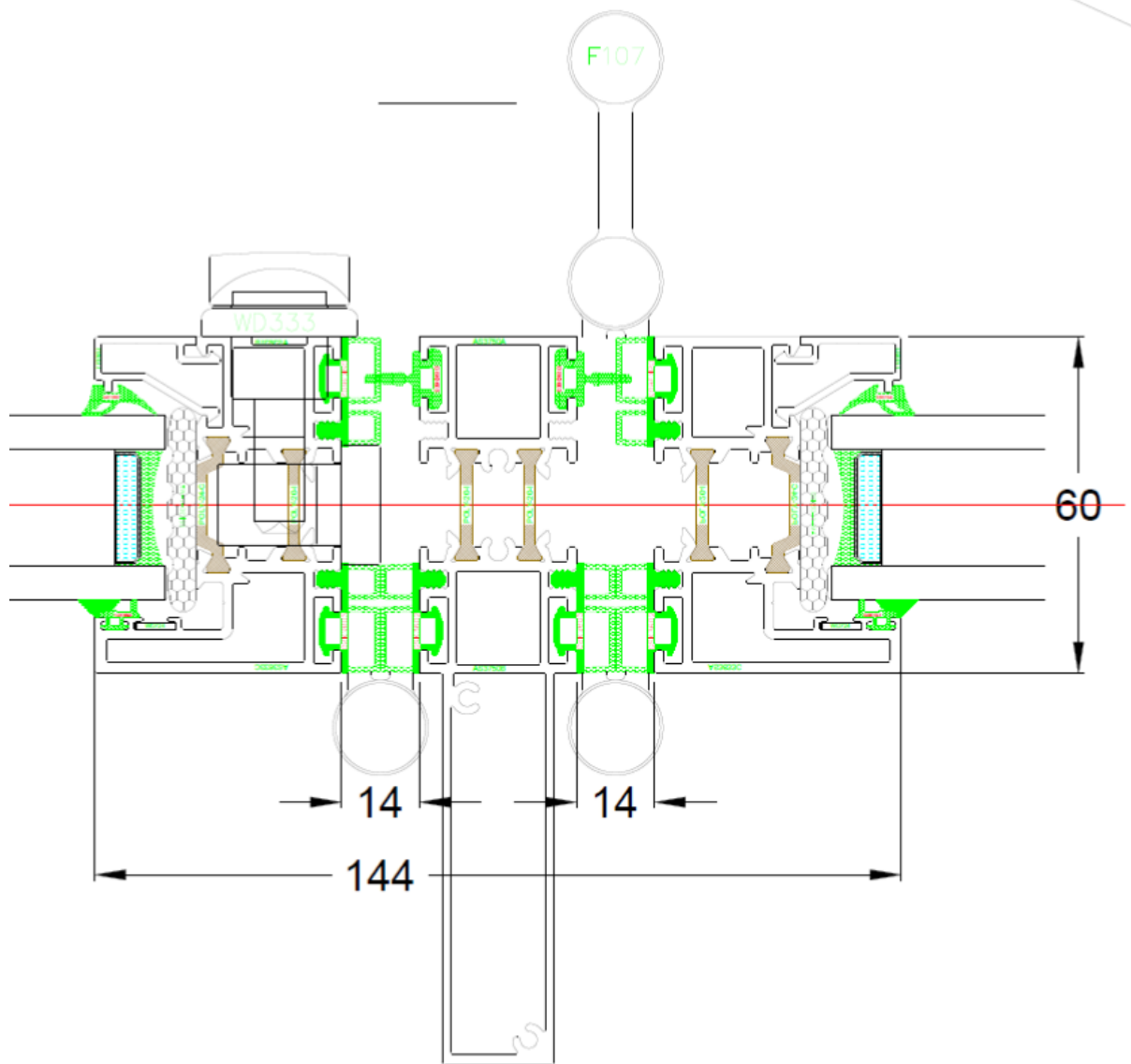

the super lux bifold

horizontal section, with fixed + vent frame

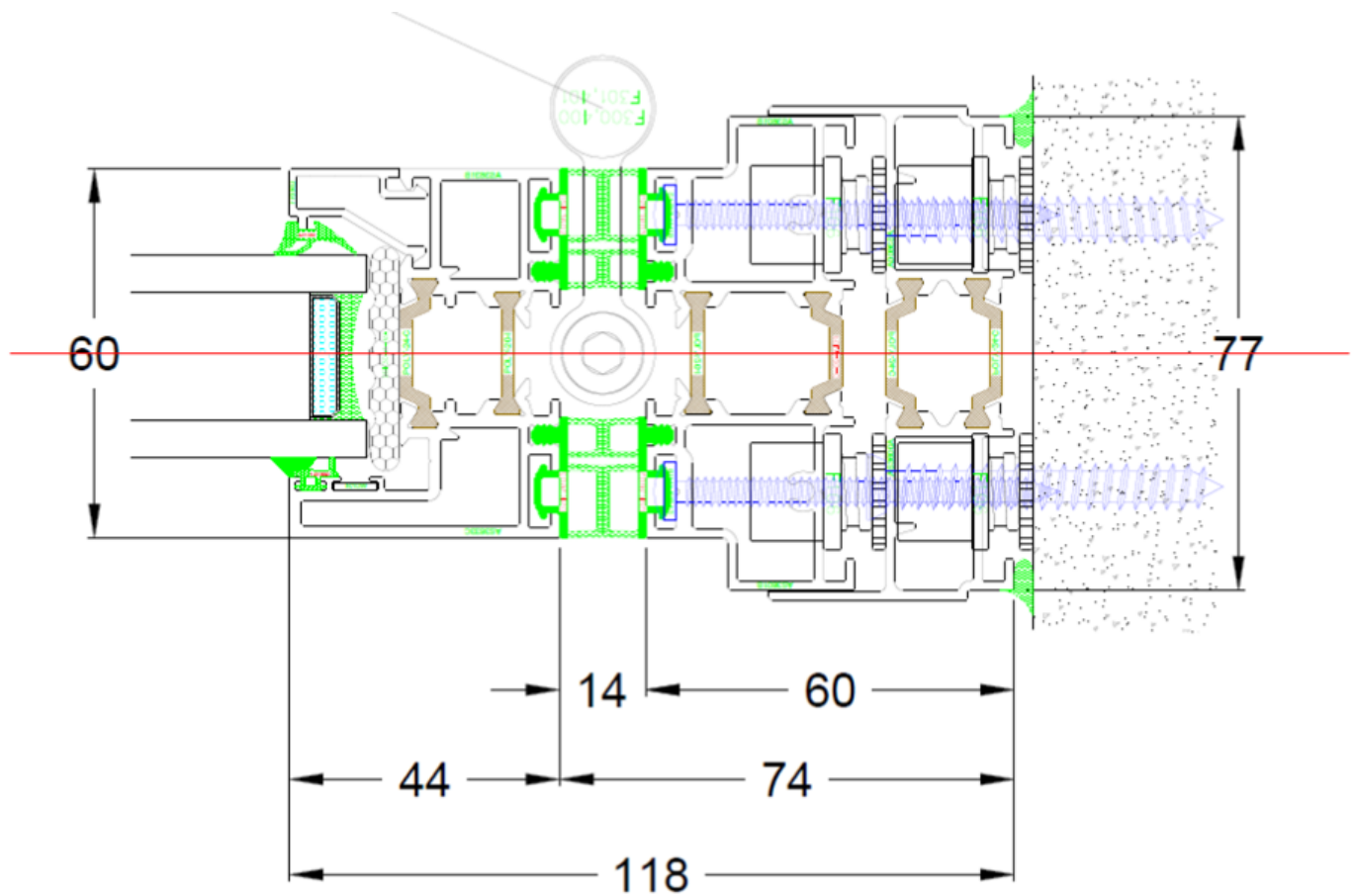

the super lux bifold



With slim aluminium framing and large sizes available, the Sieger Super Lux Bifold Door is perfect for filling large structural openings.



the super lux bifold

vertical section, head frame

adjustable head for spans over 3.8m wide

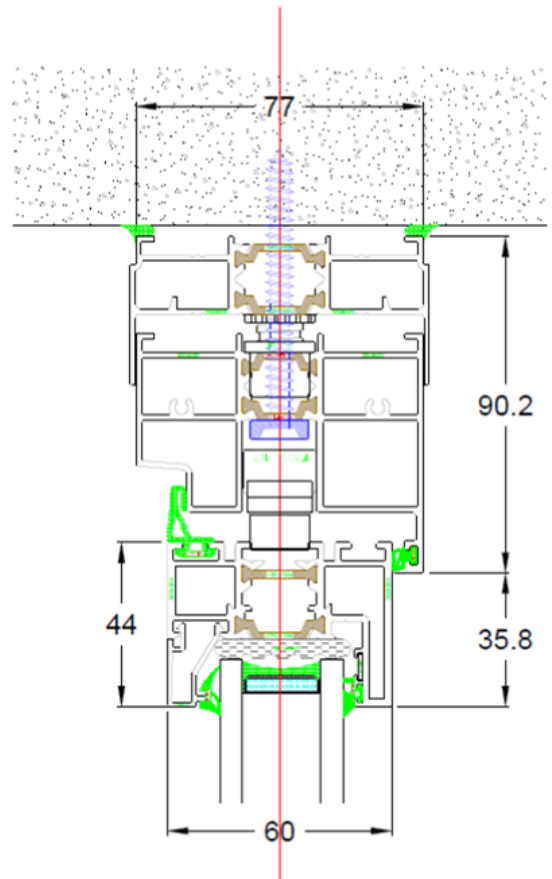
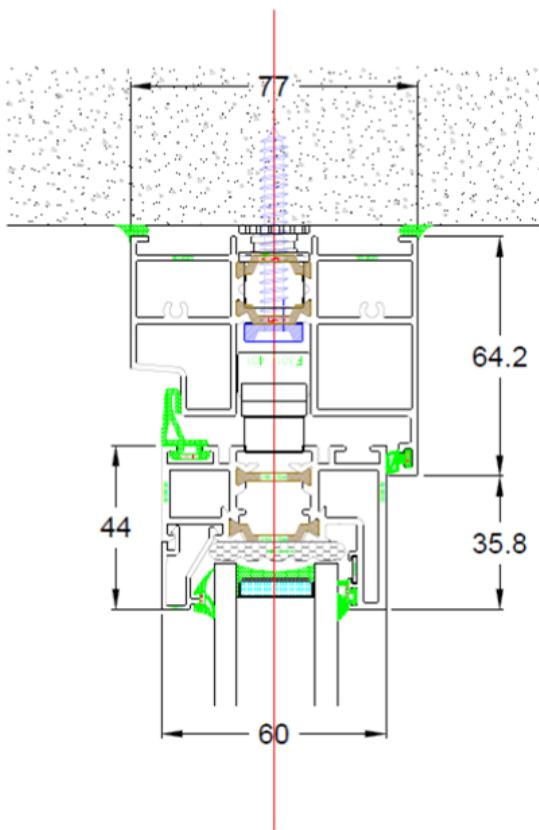

the super lux bifold

vertical section, typical base detail

water tightness Class 7A

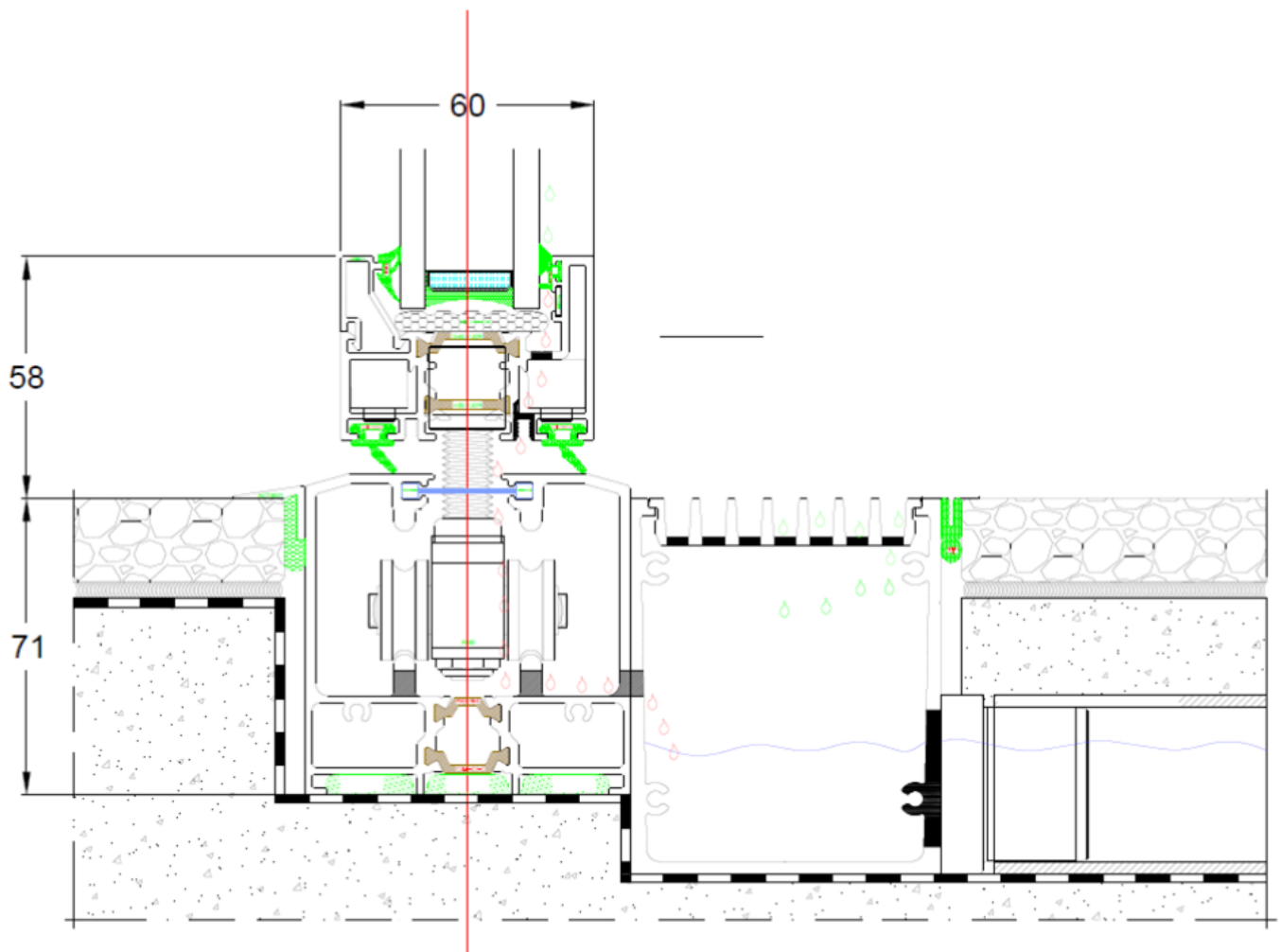

the super lux bifold

horizontal section, biparting meeting stile, even to even

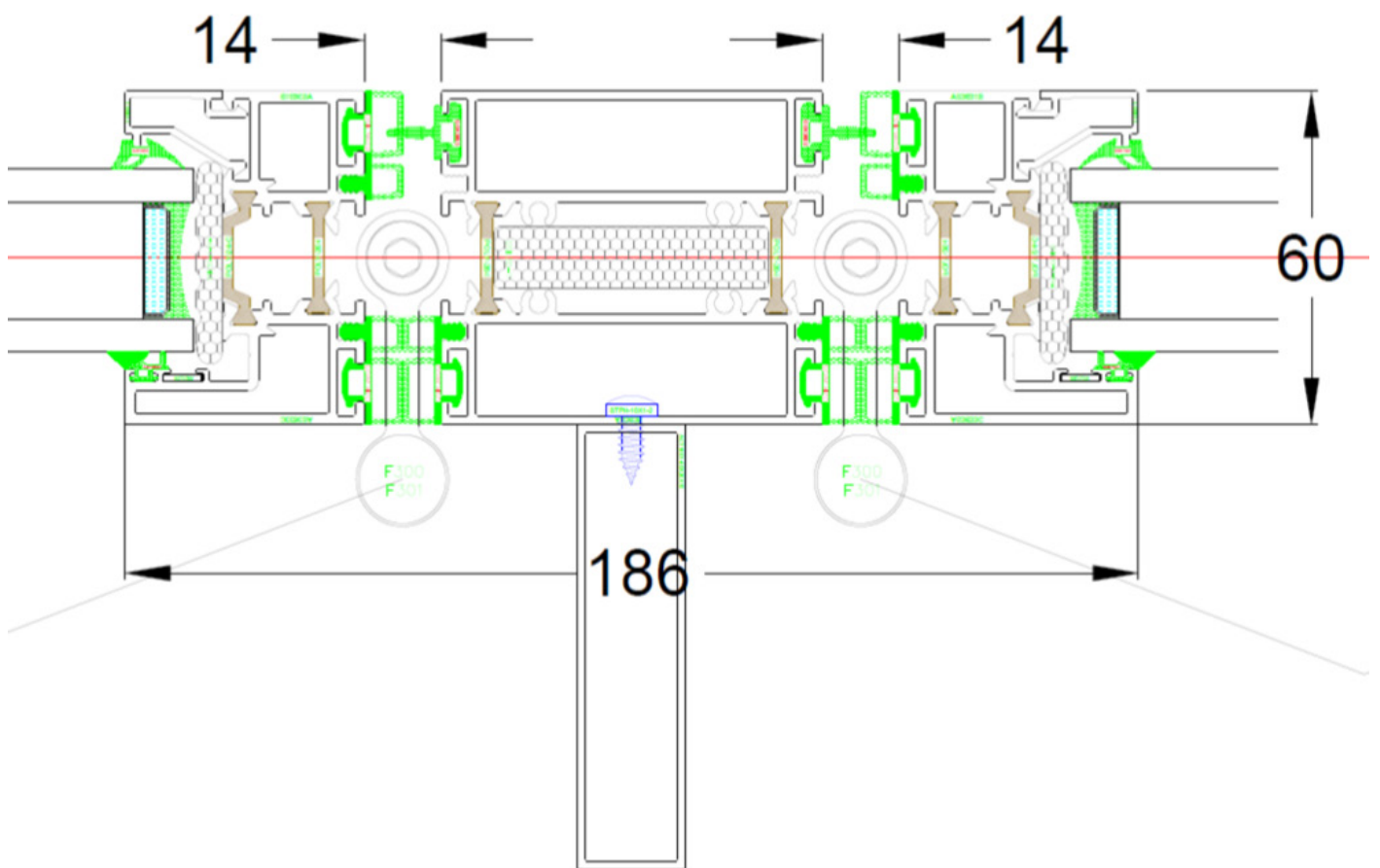

the super lux bifold

horizontal section, biparting meeting stile, even to uneven

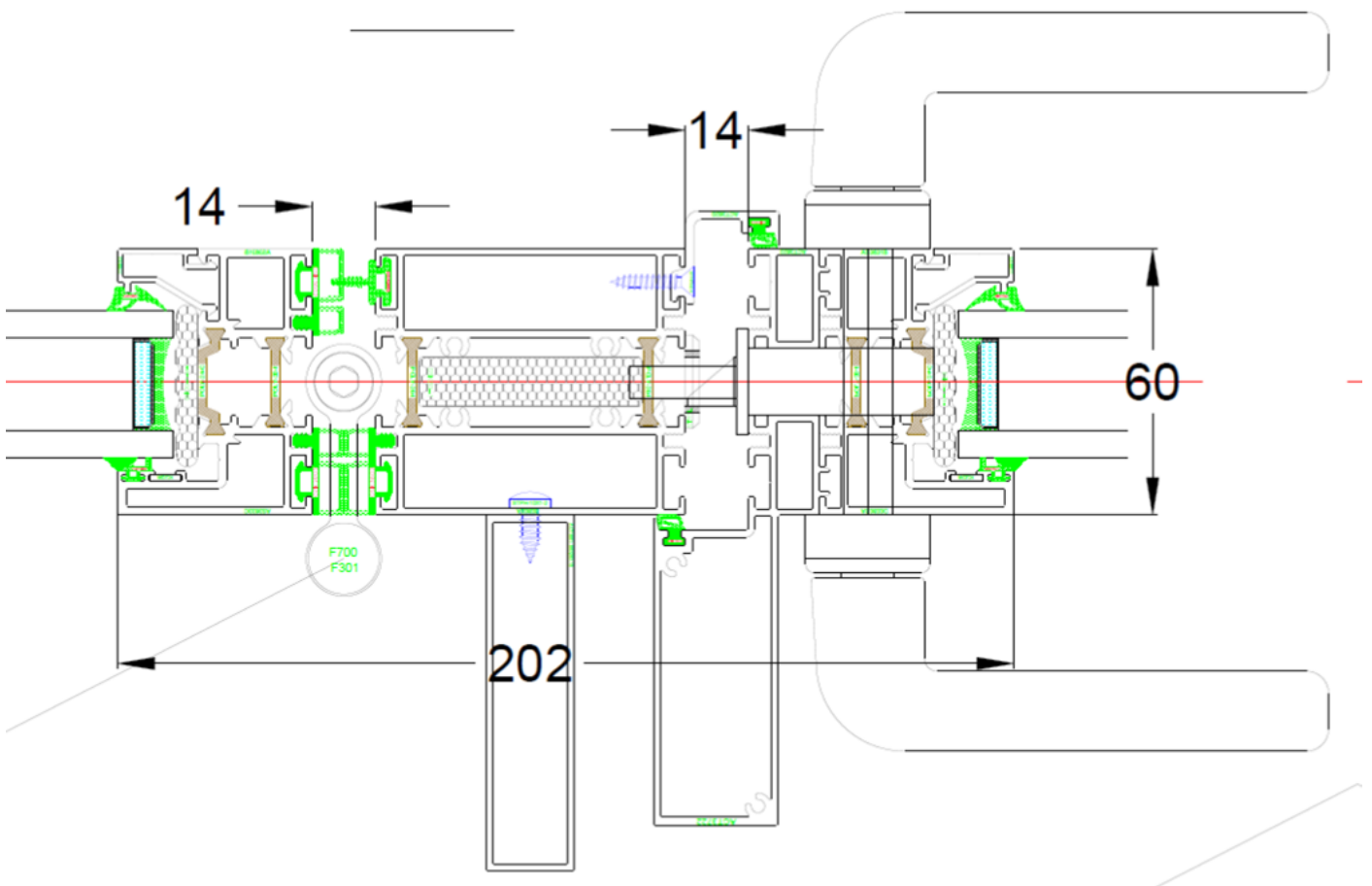

the super lux bifold

Stack Depths

two pane

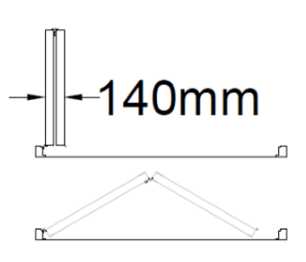

three pane

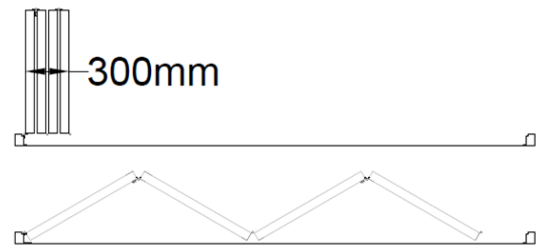

four pane, biparting

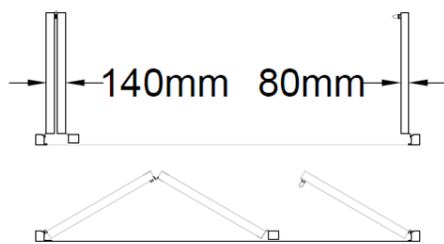

four pane

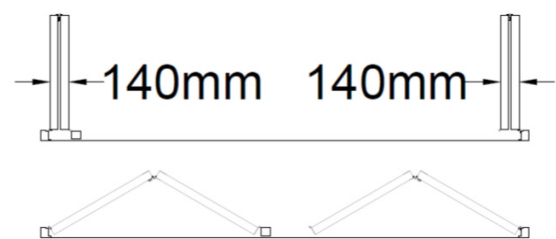

six pane

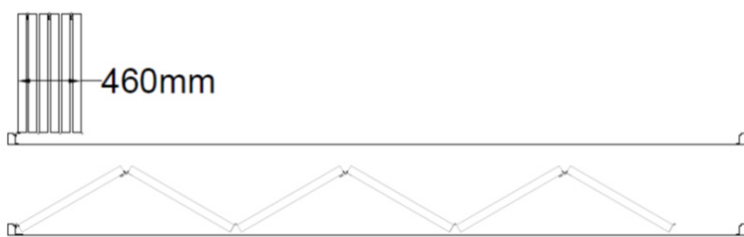

seven pane



the super lux bifold

The system can also be fabricated with any 30mm backset lock of your choice. Speak to the team for further information. Each bifold pair is locked and unlocked via a unique integrated catch system called the bifold leaf catch. This maintains the minimalistic design of the bifold frames and offers an easy solution for opening and closing.

standard lever
handle



standard pull
handle



finishes

Stocked in black.

Stocked in black.

key locking

euro cylinder lock, operatable
from inside and out

no

notes

located on lead folding door

located in between folding
panes, only accessible from
inside / can be used in con-
junction with a bifold leaf catch



STANDARD LEAF CATCH

Stocked in black.

the super lux bifold

The Sieger® Architektursystem is available exclusively from the IQ Group and associated companies.

A Sieger® Systems product will bring high quality European engineering to your project and are the first choice for architects and designers all over the UK. If you have any questions about how to specify this product for your project just speak to the team who would be happy to assist.

SPEAK TO THE TEAM

If you are considering using a Sieger® product on your project speak to the team at your chosen IQ Group glazing company. They will be able to advise you on the best solution for your intended design, ensure that all specification criteria are met and advise you on any feasibility areas of the installation you may not have considered.

GET A QUOTATION

We advise customers to get a quotation for the installation. This allows all parties to ensure that the preferred product and design is within budget. If it is not we can help you adjust the specification to reach all performance, design and budgetary requirements.

ADD US TO YOUR NBS SPECIFICATION

To assist you in specification we have created individual NBS Specification sheets for each Sieger® Systems product. These easy to navigate documents contain all the vital information needed for specification.

They are available for your to complete on your own alternatively ask your sales representative at to complete this on your behalf.

PLACE THE ORDER

When ready you (or your client or the builder) can then place the order for your products with us. A full in house handover will take place and your project will be passed to the contracts team. The project will be appointed a dedicated contracts manager who will oversee the installation process. The estimated lead time for Sieger® products is 6-8 weeks but your overall glazing lead time may be different depending on the other glazing products on your project and their lead times. Please also allow 20 working days if your project requires full glazing design drawings. This will be confirmed on order.

WHERE CAN I SEE SIEGER PRODUCTS?

The Sieger® Systems range is available to view at the Sky House Design Centre. Just contact your sales representative who will be happy to book you an appointment.

the super lux bifold

EUROPEAN DESIGN

The Sieger® Architektursystem has been designed to the highest European standards to ensure a highly engineered finish with the best performance.

Each aluminium framing profile is selected and engineered to offer a minimal and modern finish, whilst maintaining robust performance and quality standards.

The technologically advanced thermal break system offers projects unparalleled levels of thermal insulation in keeping with modern European design.

BRITISH MANUFACTURING

Every Sieger® Architektursystem product is manufactured and fabricated bespoke to each project specification. Our state of the art fabrication site offers the latest technology in modern aluminium fabrication, ensuring Sieger® Systems can offer efficient lead times and exceptional quality.

MORE INFORMATION

For more information about the Sieger® Architektursystem please contact the team who will be happy to help. Make sure you investigate our entire range to achieve a cohesive design to all elements of your building project.

Factory

Unit 9, Amersham Industrial Park
Raans Road
Amersham
HP6 6FT, UK

Showroom

Sky House Design Centre
Raans Road
Amersham
HP6 6JQ, UK

01494 722 880

sales@siegersystems.co.uk
www.siegersystems.co.uk

facebook
www.facebook.com/siegeraluminiumsystems

instagram
www.instagram.com/siegeraluminium

part of the IQ[®] Glass Group

sieger[®]