

Existing material: uPVC
Glazing: Single

W01
10.no

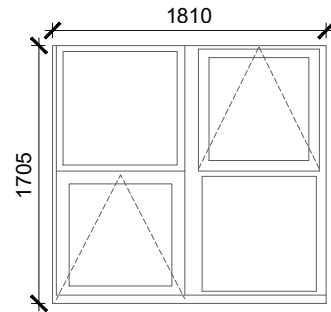

Existing material: timber
Glazing: Single

W02
2.no

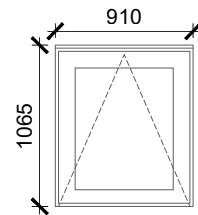

Existing material: timber
Glazing: Single

W03
6.no

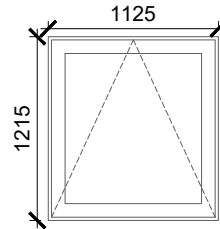

Existing material: timber
Glazing: Single

W04
2.no

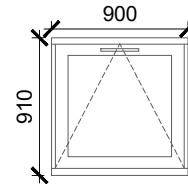

Existing material: timber
Glazing: Single

W05
3.no

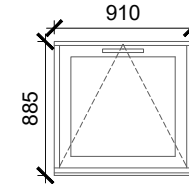

Existing material: timber
Glazing: Single

W06
7.no

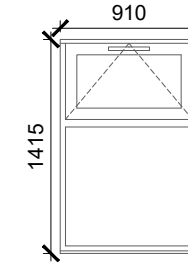

Existing material: timber
Glazing: Single

W07
2.no

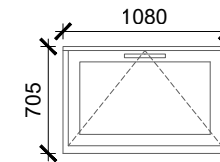

Existing material: timber
Glazing: Single

W08
1.no

1 Existing Window Schedule

Scale: 1:50 @ A3

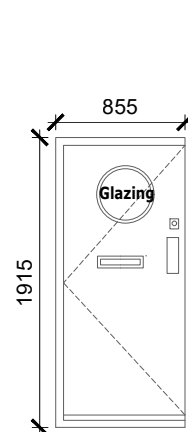

Existing material: Timber

D01
1.no

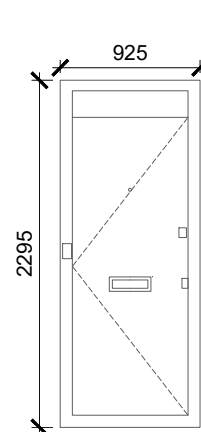

Existing material: Timber

D02
1.no

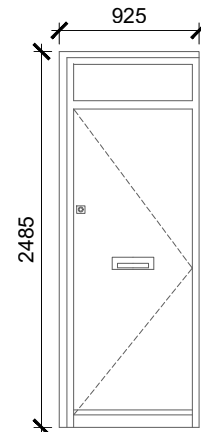

Existing material: Timber

D03
1.no

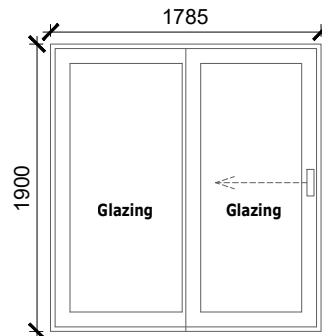

Existing material: Aluminum
Glazing: Single

D04
1.no

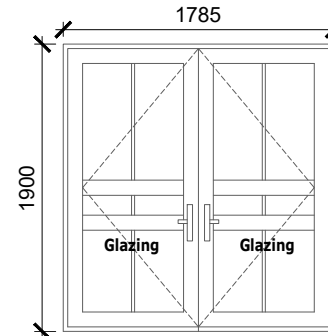

Existing material: uPVC
Glazing: Single

D05
2.no

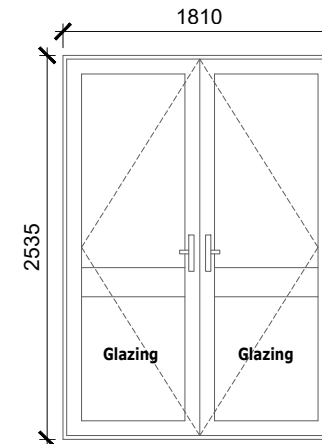

Existing material: uPVC
Glazing: Single

D06
1.no

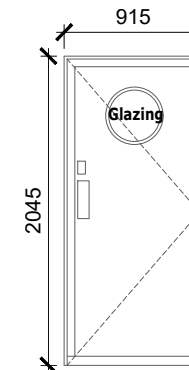

Existing material: Timber
Glazing: Single

D07
1.no

2 Existing Door Schedule

Scale: 1:50 @ A3

P3	Top hung	MO	AS	15.03.2023
P2	Revision	MO	AS	19.10.2022
P1	Planning	MO	AS	14.06.2022
Rev	Description	By	QA	DD.MM.YY

© This drawing and any design hereon is the copyright of Potter Raper and must not be reproduced without their written consent. All drawings remain the property of Potter Raper. Figured dimension only to be taken from this drawing. All dimensions to be checked on site. Please inform Potter Raper immediately of any discrepancies before work proceeds.

Client	Wates
Project Name	Capital Works

Project Location
121-123 Torriano Avenue
London
NW5 2SH

Sheet Name	Existing Window and Door Schedules
------------	------------------------------------

Project Status
Planning

Drawing Nr.
B9825-PR-TA-ZZ-DR-A-PL401

Scale 1:50 @ A3



Duncan House
1A Burnhill Road
Beckenham
Kent
BR3 3LA
Tel: 020 8658 3538

